



Smappee Infinity & EV Line Installation Procedure

Mathieu Berteloot – Persyn Michaël

mb@eco-tronic.eu

1-06-2021

Agenda

Part 1 - Infinity installation Procedure (1 hour)

- Installation – selection of components
- Physical installation & configuration
- Tips & tricks
- Validation & Troubleshooting

Part 2 - EVLine installation Procedure (1,5 hour)

- EVLine options
- EVBase of EVWall Business
- EVWall (Home)



Target audience: installers, project managers, support staff



Smappee EV Line Installation Training

Koenraad Achten – Presales & Project Manager
k.achten@smappee.com
March, 2021

Smappee EV Line

Home	Business	
 <p data-bbox="357 436 614 468">Smappee EV Wall</p> <ul data-bbox="160 743 529 848" style="list-style-type: none"> • Energy and charging data • Overload protection • Solar optimisation <p data-bbox="160 896 587 962">Infinity & Smart Charging Package included!</p> <p data-bbox="160 1011 633 1076">Use only for residential single EV Wall installations.</p>	 <p data-bbox="925 436 1174 508">Smappee EV Wall Business</p> <ul data-bbox="745 743 967 811" style="list-style-type: none"> • Charging data • MID metering <p data-bbox="745 859 1170 925">Infinity & Smart Charging Package need to be purchased separately:</p> <ul data-bbox="745 936 1155 1082" style="list-style-type: none"> • Energy data • Overload protection • Solar optimisation • Extension to 5 year warranty 	 <p data-bbox="1624 436 1761 508">Smappee EV Base</p> <ul data-bbox="1319 743 1541 811" style="list-style-type: none"> • Charging data • MID metering <p data-bbox="1319 859 1744 925">Infinity & Smart Charging Package need to be purchased separately</p> <ul data-bbox="1319 936 1734 1082" style="list-style-type: none"> • Energy data • Overload protection • Solar optimisation • Extension to 5 year warranty

Smappee EV Line

Home



Smappee EV Wall

- Energy and charging data
- Overload protection
- Solar optimisation

Infinity & Smart Charging Package included!

Use only for residential single EVWall installations.

EVWall (Home) can only be used for:

- Residential installations
- New installations that have no Infinity installed yet.
- For single EVWall unit installations (1 connector)



If multiple EVWall (Home) unit are needed in residential environment, use the EVWall Business with separate Infinity.

EVWall (Home) does not support the use of Output of other Infinity accessories (Switch, Gas & Water, Input module).

Additional CTHubs for metering points IS possible.

Installation procedure – EV Line Business

1. Preparing the installation: To prepare the physical installation
2. Installation and activation: The steps for the physical installation

Smappee EV Line

Home



Smappee EV Wall

- Energy and charging data
- Overload protection
- Solar optimisation

Infinity & Smart Charging Package included!

Business



Smappee EV Wall Business

- Charging data
- MID metering

Infinity & Smart Charging Package need to be purchased separately:

- Energy data
- Overload protection
- Solar optimisation
- Extension to 5 year warranty



Smappee EV Base

- Charging data
- MID metering

Infinity & Smart Charging Package need to be purchased separately:

- Energy data
- Overload protection
- Solar optimisation
- Extension to 5 year warranty

Step 1. Preparing the installation

EV Line Business

Overload and Solar optimization capability

- Install a Smappee Infinity with the following Load Configuration:
 - Grid (main feeder): used for Overload protection capability
 - Solar: in case a multiple inverters, all need to be measured to obtain total solar production of the site
- Example 1:
 - Smappee Infinity for only CTmeasurements to support Smart Charging
 - Grid - 3P+N – 50A max current per phase
 - Solar – 3P+N – 50A max current per phase
 - BOM – Infinity components:

Article number	Article description	Quantity
I1-VAC-1	Smappee Power Box	1
I1-GW-3	Smappee Connect	1
I1-IAC-1	Smappee CT Hub	2
AC-CT-S-50A	CT T10/50A 30cm / 11.81 inches	6

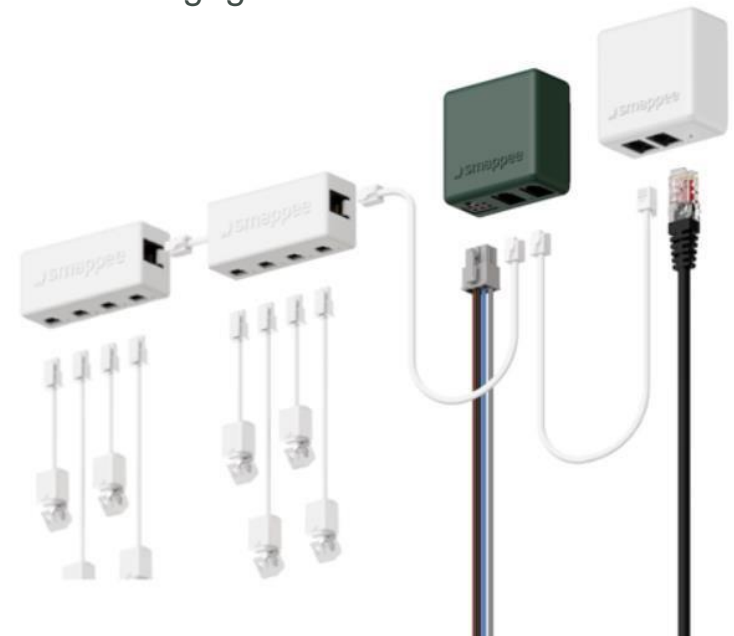

Step 1. Preparing the installation

EV Line Business



Overload and Solar optimization capability

- Install a Smappee Infinity with the following Load Configuration:
 - Grid (main feeder): used for Overload protection capability
 - Solar: in case a multiple inverters, all need to be measured to obtain total solar production of the site
- Example 3:
 - Smappee Infinity for only CT measurements to support Smart Charging, and ability to switch appliances on and off (contactor or Smart-GridReady Heatpump):
 - Grid - 3P+N – 50A max current per phase
 - Solar – 1P+N – 50A max current per phase
 - HVAC- 3P+N - 50A max current per phase
 - BOM – Infinity components :

Article number	Article description	Quantity
I1-VAC-1	Smappee Power Box	1
I1-GW-1	Smappee Genius	1
I1-IAC-1	Smappee CT Hub	2
I1-OUT-1	Infinity Output module	1
AC-CT-S-50A	CT T10/50A 30cm / 11.81inches	7



Smappee EV Line

Home	Business	
 <p data-bbox="359 482 614 515">Smappee EV Wall</p> <ul data-bbox="160 791 529 896" style="list-style-type: none"> • Energy and charging data • Overload protection • Solar optimisation <p data-bbox="160 943 587 1011">Infinity & Smart Charging Package included!</p> <p data-bbox="166 1182 664 1249">Internet connectivity at the distribution panel</p> <ul data-bbox="166 1258 465 1325" style="list-style-type: none"> • Ethernet (preferred) • 2.4 GHz Wi-Fi 	 <p data-bbox="925 482 1174 558">Smappee EV Wall Business</p> <ul data-bbox="745 791 967 858" style="list-style-type: none"> • Charging data • MID metering <p data-bbox="745 905 1170 972">Infinity & Smart Charging Package need to be purchased separately:</p> <ul data-bbox="745 981 1157 1125" style="list-style-type: none"> • Energy data • Overload protection • Solar optimisation • Extension to 5 year warranty <p data-bbox="745 1182 1161 1215">Internet connectivity for the unit</p> <ul data-bbox="745 1219 958 1249" style="list-style-type: none"> • Ethernet only 	 <p data-bbox="1624 482 1760 558">Smappee EV Base</p> <ul data-bbox="1319 791 1541 858" style="list-style-type: none"> • Charging data • MID metering <p data-bbox="1319 905 1744 972">Infinity & Smart Charging Package need to be purchased separately</p> <ul data-bbox="1319 981 1731 1125" style="list-style-type: none"> • Energy data • Overload protection • Solar optimisation • Extension to 5 year warranty <p data-bbox="1319 1182 1586 1215">Internet connectivity</p> <ul data-bbox="1319 1219 1692 1325" style="list-style-type: none"> • Ethernet (preferred) • 2.4 GHz Wi-Fi (alternative) • 4G (contact Smappee)

Step 1. Preparing the installation

Installation prerequisites

- Check topology: 3P+N (3*400V – Star), 3P (3*230V – Delta), 1P+N (1*230V)
- Calculate the existing electrical load to find the maximum operating current for the charging station installation.
- The minimal recommended wire gauge is 6 mm².
- Refer to local wiring regulations to select the conductor sizes.
- Use only copper conductors.
- 1x power supply cable per connector (2x per EVBase, 1x EVWall)
- 1x CAT5/6 UTP communication cable:
 - EVWall Business & EVBase: providing internet connection
 - EVWall (Home): going to distribution panel where Infinity components are to be installed



If 4G cellular network is required, please contact Smappee.

For 3P (3*230V) – Delta installations, see remarks

IMPORTANT notes for 3P (3*230V) – Delta

Some EV-vehicles are not compatible with 3P (3*230V) grid connection due to an built-in security in the EV.

- Type 1: One of the phases is in the low voltage cabin connected to earth. The voltage between ground & 1 of the phases is 0 volts.
- Type 2: None of the phases are connected to earth. The voltage between each phase and earth is 130V.

Check prior to the EVWall installation the type of Delta Topology by measuring the voltage between the phases and ground.

- If 0 Volts => Type 1: all EV cars can charge. The phase that provides 0V needs to be connected to the Neutral of EVWall power supply.
- If 130V Volts (not 0V) => Type 2:
 - If a specific EV is to be charged, check with the EV manufacturer if compatible with this setup.
 - If a specific EV is not compatible or multiple EV-types need to be charged, an isolation transformer needs to be installed.



Dynamic loadbalancing with or without an isolation transformer for the power supply of the EVWall is supported. (cfr. Type 2 – Delta installation).

Step 1. Preparing the installation

Tools (not included)

Multimeter and earth ground meter

Screwdrivers

2.5mm & 3 mm Hex screwdriver

7 mm socket wrench

Wire stripper and cutter

Needle-nose pliers

Ferrules crimper, for stranded power supply cables

Drill and rock drill diameter 6 & 12mm.

18 mm socket wrench with ratchet handle

Hammer

RJ45 crimping tool

Mobile device

Supplies (not included)

Ethernet cable or RJ45 connector for wired communication.

Power supply cables

Ferrules, for stranded power supply cables

Circuit breaker

Diff. Type B (for multiple charge connector setups)

Firewall rules

- Your firewall should allow Smappee to create outbound secure HTTP connections.
- No specific firewall settings are required in your network. If you use a firewall, use the commonly applied secure firewall rules:
 - Inbound communication: All inbound ports closed. No port forwarding.
 - Outbound communication: All outbound ports allowed.



See firewall rules in Addendum 2 of the Infinity Installation manual.

Step 1. Preparing the installation

Electrical cabinet layout & protection

- Each EVline has built-in differential protection per connector:
 - Type A (30 mA AC)
 - 6 mA DC (RCM)

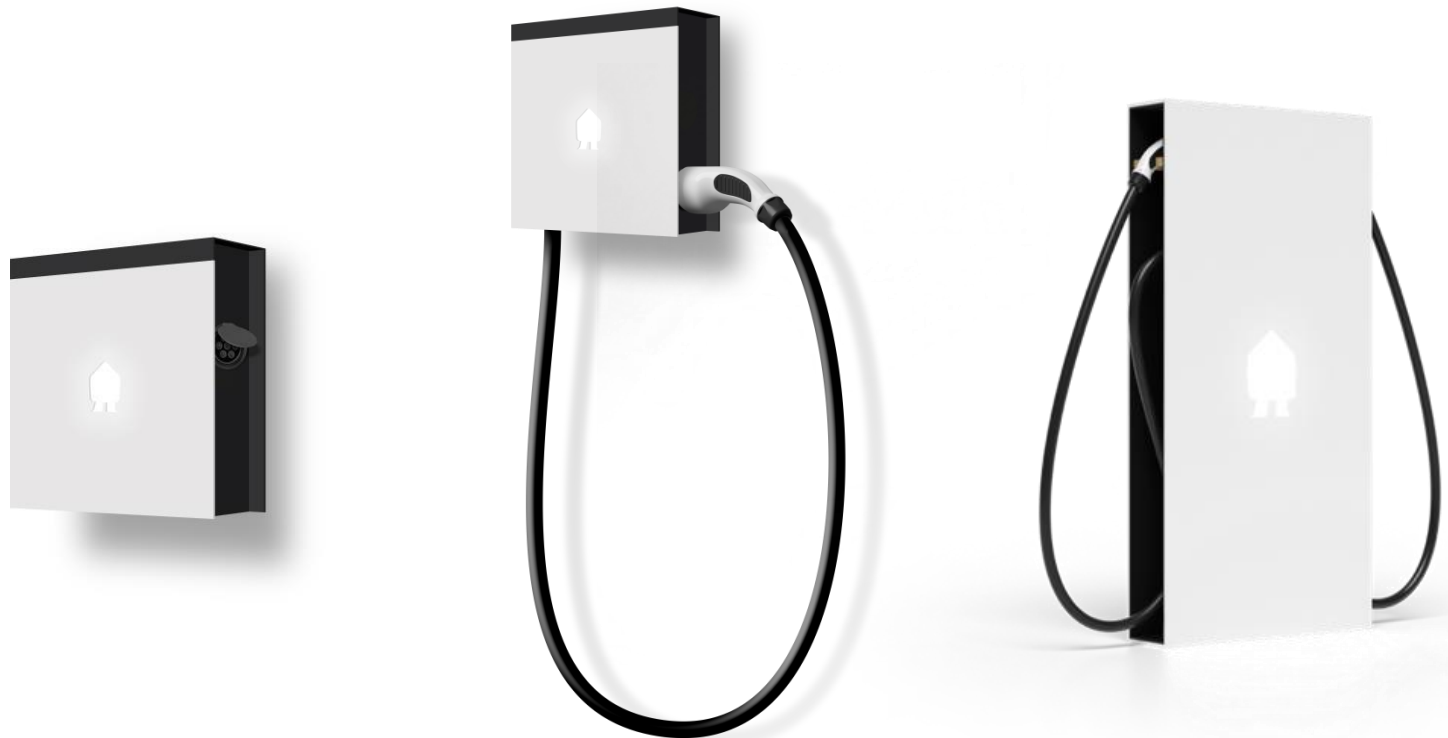

Step 1. Preparing the installation

Electrical cabinet layout & protection

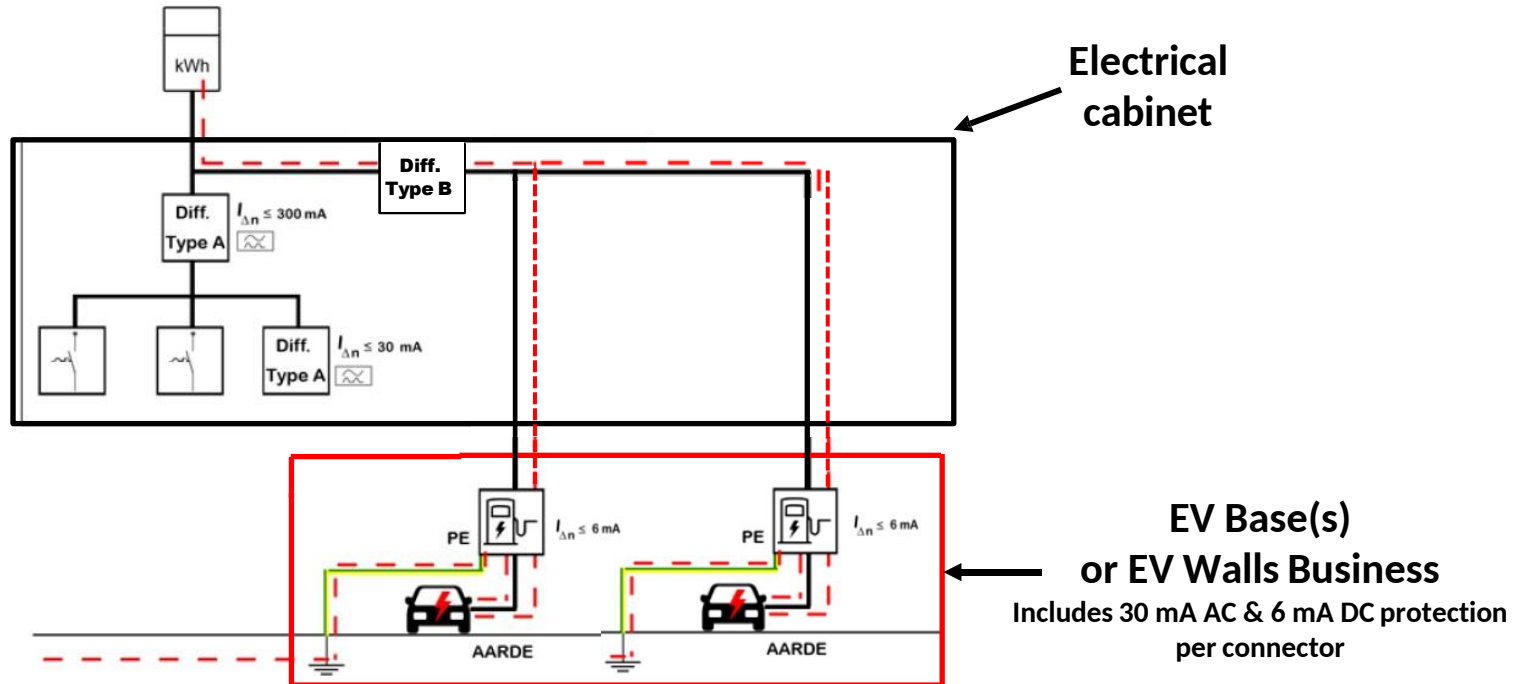

Suggestion: Divert EVcharger supply before the regular Differential to isolate potential issues from the EVchargers with the standard electrical installation.

DC protection of all charging stations combined needs to be a maximum of 6 mA DC



CAUTION: The installer must ensure that the charging station is installed in accordance with the relevant national and local regulations.

EV Wall Business – supplied components

- 1 x Smappee EVWall unit
- 1 x Mounting plate
- 1 x Plastic bag containing installation material (3x wall plugs, 3x M4 screws and 2 M4 nuts)
- 1x 2.5m or 8m fixed cable (for fixed cable version)
- 1x Cable holder (included only with 8m fixed cable version)



EV Base – supplied components

- 1x EV Base
- 4x concrete anchors
- 4x washers (diameter 50 mm)
- 1x floorplate

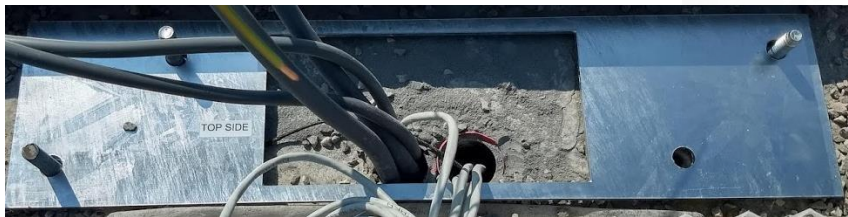

Installation procedure – EV Base

1. Preparing the installation: To prepare the physical installation
2. Installation and activation: The steps for the physical installation



Step 1. Preparing the installation

Prepare the mounting foundation

- Smappee EVBase is designed to be installed at ground level
- Prepare a stable and levelled concrete foundation at ground level

Guidelines:

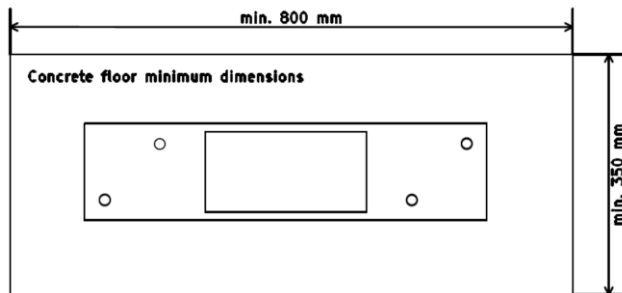

Depth: 30 cm

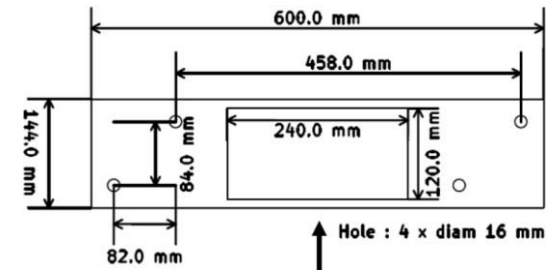

Make the support a bit bigger than the floor plate.



Weight: 20 kg (28 kg incl. 2 cables)

Dimensions: 1200 x 600 x 150 mm (station)

Depending on the subsoil, the size may vary.

Step 1. Preparing the installation

Prepare the mounting foundation

Alternative to a solid concrete support

- Create a support frame by use additional floor plate with 4x40 cm M10 screw threads
- Mount into the ground and add fast concrete at the bottom and fill the remaining volume with sand.

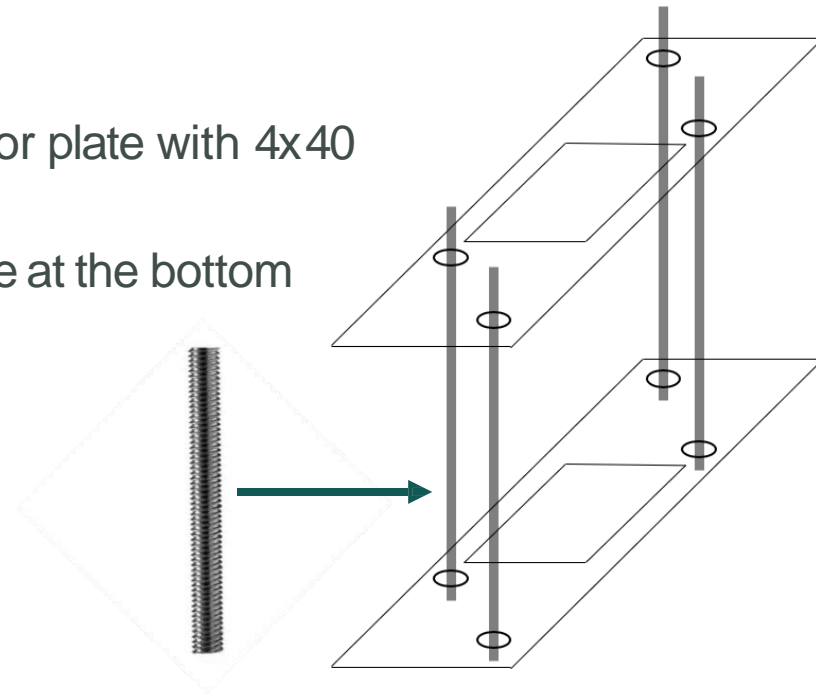

Additional floor plates can be purchased separately.

Depending on the subsoil, the size may vary.

Step 1. Preparing the installation

Prepare the mounting foundation
Alternative to a solid concrete support

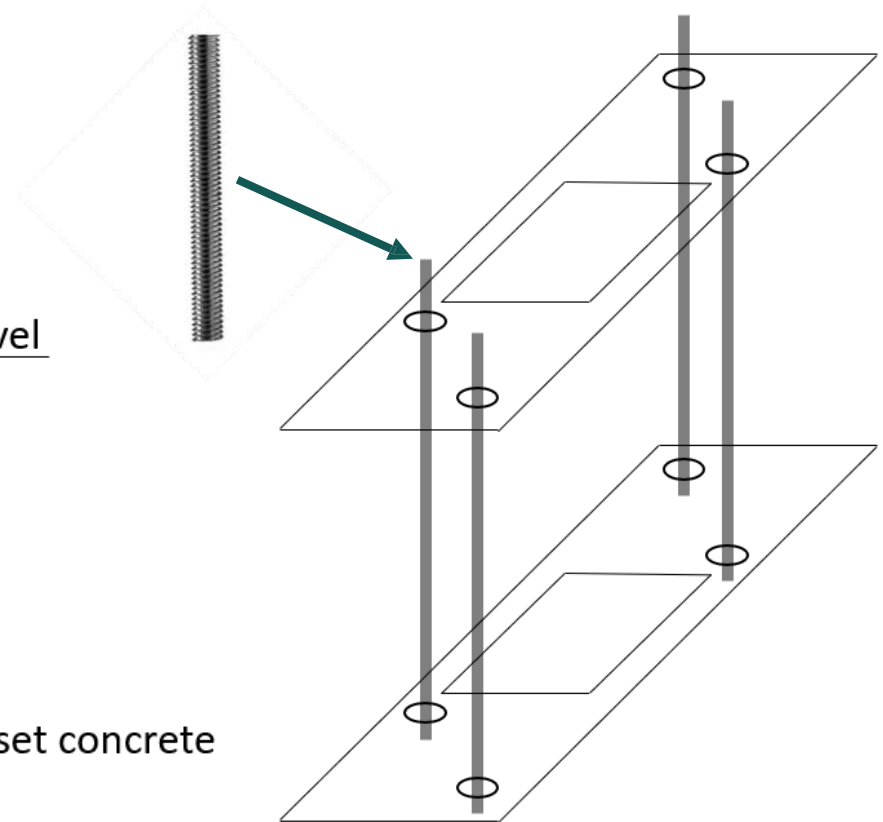
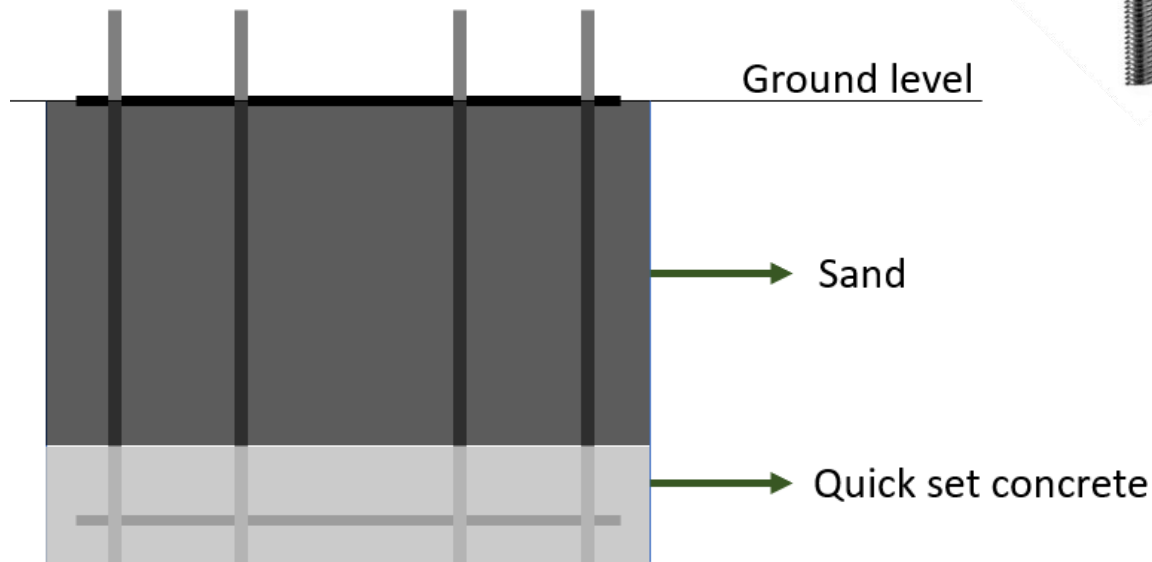

Weight: 20 kg (28 kg incl. 2 cables)
Dimensions: 1200 x 600 x 150 mm (station)

Depending on the subsoil, the size may vary.

Step 1. Preparing the installation

Prepare the mounting foundation



It is also possible to have the foundation a little lower than ground level so mask the mounting screws.

Step 1. Preparing the installation

Route power supply

- Route the power supply cables and the Ethernet cable to the position where the charging station will be installed.
- Make sure the power supply cables are positioned through central position of the floor plate recess.
- Make sure that there is at least 60 cm of cable available out of the ground.

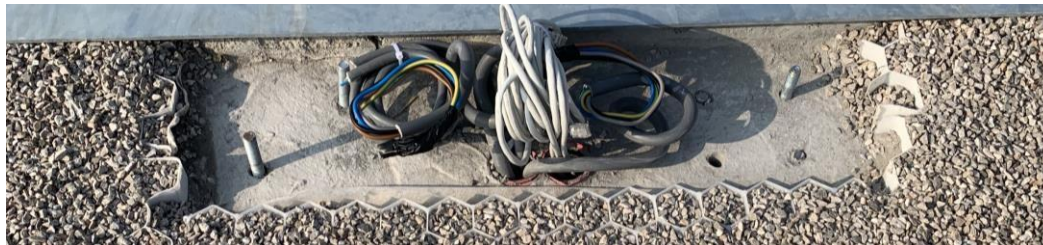

Step 1. Preparing the installation

Route power supply

- Floor plate dimensions:
=> Is same size as the EV Base

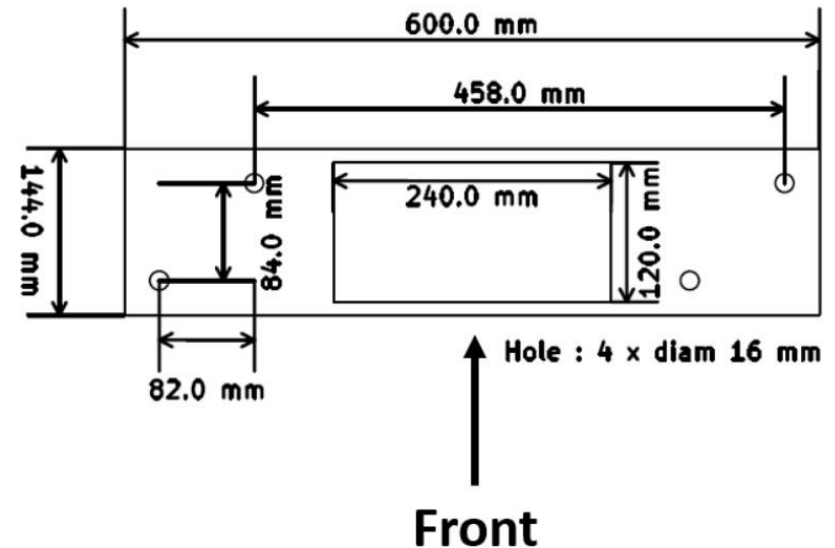

'Top Side' indication on the Floor plate must be facing up.

Step 1. Preparing the installation

Route power supply

The maximum power rating for each connector is specified in the table below.

Power per connector	Connection	Input current	Output current
3.7 kW	1-phase	1 x 16 A	1 x 16 A
11 kW	3-phase	3 x 16 A	3 x 16 A
22 kW	3-phase	3 x 32 A	3 x 32 A



During configuration, the maximum output current of each connector can be limited (max. 22 kW – 32A).



CAUTION: Make sure it is not possible to connect the electric current during installation. Put up caution tape and warning signs to mark the work areas. Make sure no unauthorised people can enter the work areas.

Installation procedure – EV Base

1. Preparing the installation: To prepare the physical installation
2. Installation and activation: The steps for the physical installation



Step 2. Installation and activation

Mount the anchors and floorplate

- Use the floor plate to mark the position of the anchors.
- Drill 4 holes of 12 mm diameter through the slots to a depth of 70 mm.
- Insert the supplied concrete anchors (4x).



'Top Side' indication on the Floor plate must be facing up.

Step 2. Installation and activation

Mount the anchors and floorplate

- Mount the floor plate over the anchors.
- Make sure it is level in both directions.



Tip: use large washers to tilt the floor plat to a levelled state (not supplied).

Step 2. Installation and activation

Place the EVBase in position

- Remove the backplate of the EVbase and position this on the floor plate.
- Place the EVBase in position.



Step 2. Installation and activation

Place the EVBase in position

- Position the one of the four supplied large washers (Ø 50 mm) over each of the 4 screw threads (anchors)
- Place the nuts and handtighten.



Do NOT torque the four nuts yet. This is done in the last step of the installation, when the back cover of the EVBase is in place.

Step 2. Installation and activation

Power supply connection

- Cut both the power supply cables to adequate length (and add the ferrules in case of stranded cable).
- Make sure the grounding resistance is within acceptable limits
- Connect each supply cable to the correct terminal block.

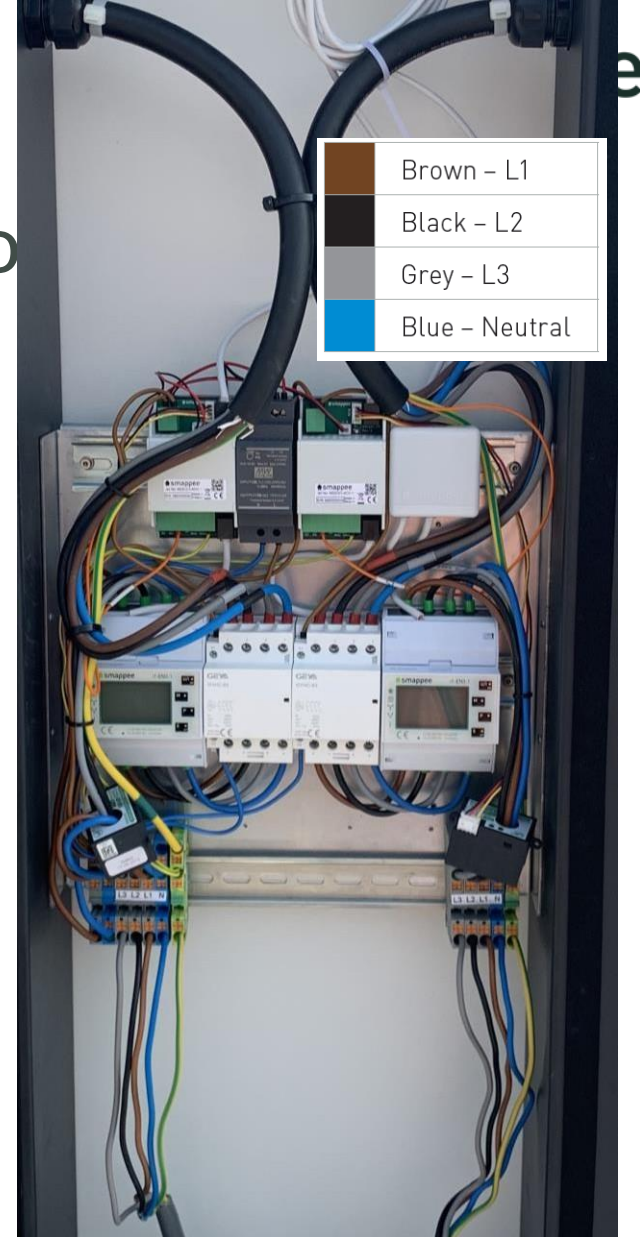

Note: this picture does not show the diff. Type A 30 mA AC protection

Step 2. Installation and activation

	Brown – L1
	Black – L2
	Grey – L3
	Blue – Neutral

Power supply connection – Phaserothation

EV Base	Connector	Phase mapping
EV Base 1	Connector 1	L3 – L2 – L1 – N (as indicated on the label)
	Connector 2	L1 – L3 – L2 – N
EV Base 2	Connector 1	L2 – L1 – L3 – N
	Connector 2	L3 – L2 – L1 – N (as indicated on the label)
EV Base 3	Connector 1	L1 – L3 – L2 – N
	Connector 2	L2 – L1 – L3 – N

EV Base 1

Connector 1



Connector 2

EV Base 2

Connector 1



Connector 2



When phase rotation is applied on a connector adjust the configuration in the Smappee Dashboard. If false, the dynamic load balancing will not operate correctly.

Step 2. Installation and activation

Internet connectivity

- Mount the Ethernet cable in the Smappee Connect



Foresee an Ethernet cable (preferred) or Wi-Fi at the location of the EVBase

If 4G cellular network is required, please contact Smappee.

Step 2. Installation and activation

	Brown – L1
	Black – L2
	Grey – L3
	Blue – Neutral

Switching on the EVBase

- Check all connections are secure and power-up both power supplies of the EVbase.
- Check the status LEDs:
 - Connect – Blue flashing
 - Both RCM – ON light active
 - Ambient light is illuminated - white fixed
 - Both MID-meters are powered on
 - Both Charging controllers: green flashing light (1 x per 3 seconds)

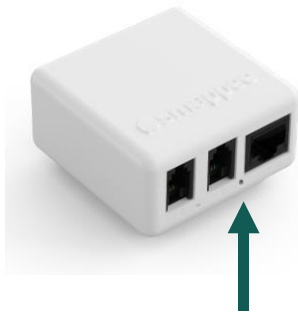

Installation procedure – EV Wall Business

1. Preparing the installation: To prepare the physical installation
2. Installation and activation: The steps for the physical installation

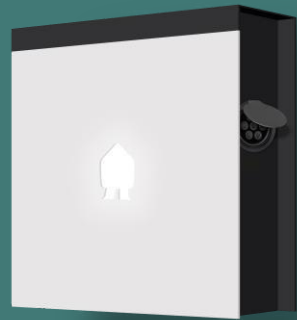

Step 1. Preparing the installation

Route power supply & ethernet cable

- Route the power supply cables and Ethernet cable for internet connectivity.
- When positioning the EVWall, take into account that the power supply cables and ethernet cable are entering the housing at the bottom through cable glands:
 - Central M32 cable gland is for power supply
 - The M20 for the ethernet cable

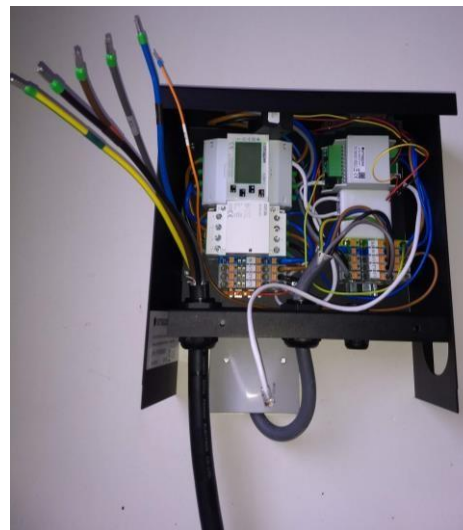

Installation procedure – EV Wall Business

1. Preparing the installation: To prepare the physical installation
2. Installation and activation: The steps for the physical installation

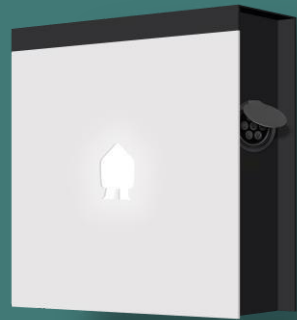

Step 2. Installation and activation

EV Wall Business

Place the EVWall in position

- Remove the front plate of the EVWall.
- Put away the front plate to avoid damaging the PCB-board attached to it.
- Attach the EVWall housing to the mounting plate using supplied M4 2.5mm HEX screws (3 pieces).

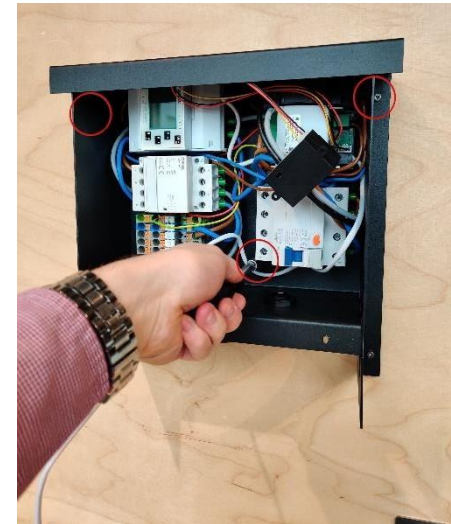
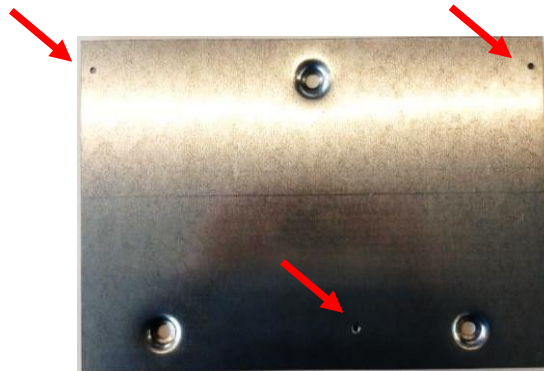
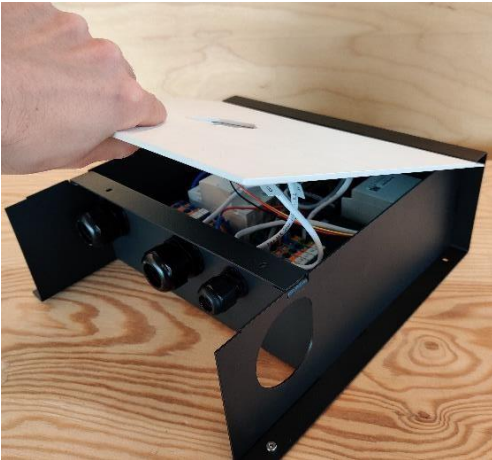

Slide the power cable through the cable glands first before mounting the EVWall housing the mounting plate.

Step 2. Installation and activation

EV Wall Business

Power supply connection & internet connectivity

- Mount the power cable through the central cable gland (M32)
- Connect each supply cable to the in-built differential switch (Type A) and respect the phase-numbering:
 - L1, L2,L3,N to Diff. Type A
 - Ground (6 mm²) to connecting block

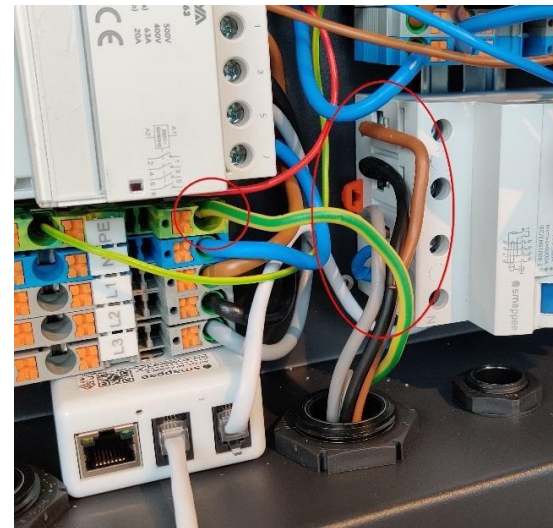
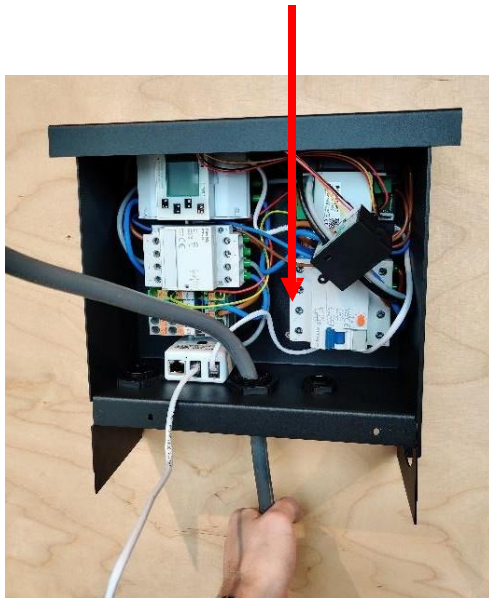

Step 2. Installation and activation

EV Wall Business

Power supply connection

- If charging station is connected as single-phase, connect the power supply cable to L1 and Neutral.

Step 2. Installation and activation

IMPORTANT notes for 3P (3*230V) – Delta



Power supply connection

- In case the charge point is connected to a 3x230V with isolation transformer is used, connect the power supply cables as follows:
- EVLine is connected as a single phase (1P):

EVLine power supply cable
from distribution cabinet

	Brown – L1
	Black – L2
	Grey – L3

EVLine power supply input

	Brown – L1
	Black – L2
	Grey – L3
	Blue – Neutral



Step 2. Installation and activation EV Wall Business

	Brown – L1
	Black – L2
	Grey – L3
	Blue – Neutral

Mount fixed cable

- Through left cable gland:
 - Tighten the Cable gland
 - Add cable tie for mechanical strain relief (supplied)

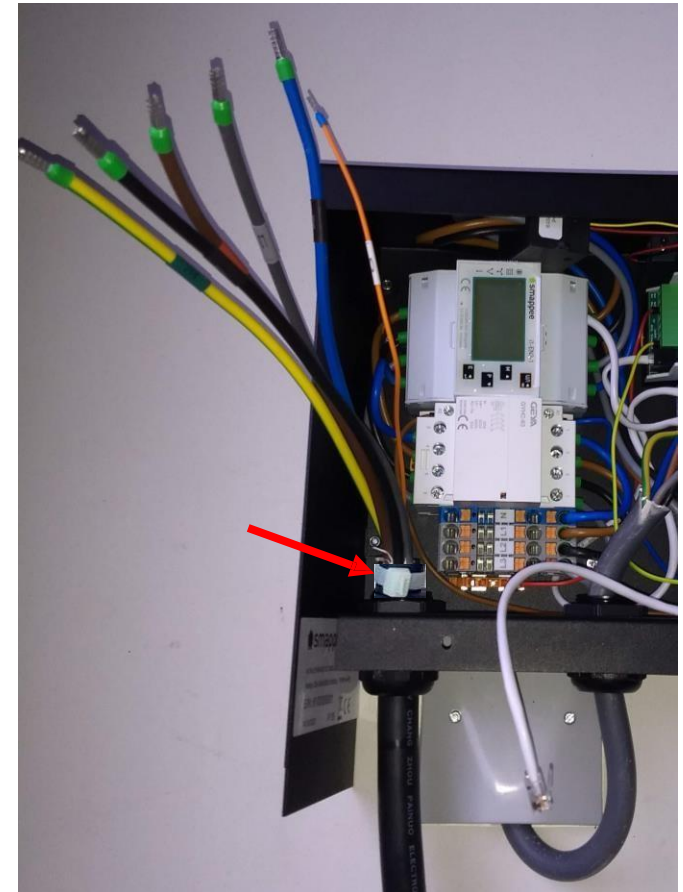

Fixed cable can be shortened to the appropriate length and have ferrules added (not included in the package).

Step 2. Installation and activation

EV Wall Business

	Brown - L1
	Black - L2
	Grey - L3
	Blue - Neutral

Mount fixed cable

- Through left cable gland:
 - Tighten the Cable gland
 - Add cable tie for mechanical strain relief (supplied)
- All wires need to be connected to connector block
 - L1, L2, L3, N and ground (6 mm²)
 - CP cable (1,5 mm³) orange

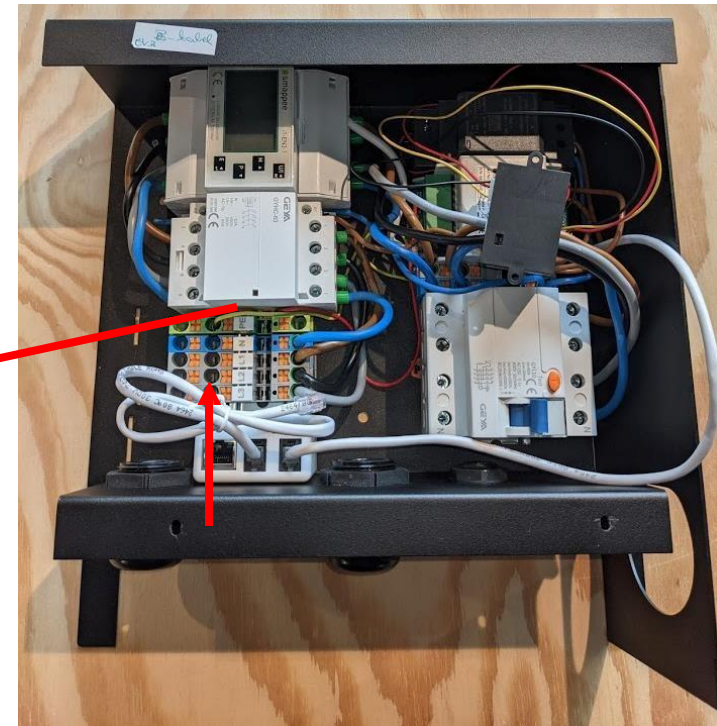
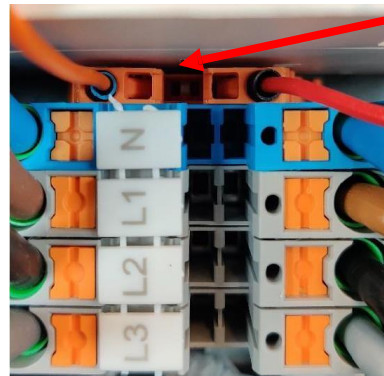

Fixed cable can be shortened to the appropriate length and have ferrules added (not included in the package).

Step 2. Installation and activation

EV Wall Business

	Brown - L1
	Black - L2
	Grey - L3
	Blue - Neutral

Power supply connection & internet connectivity

- Add the CAT.5/6 communication cable (internet connection) through right cable gland (M20)
- Attach an RJ45 connector to the Ethernet cable after feeding it through the cable gland. Plug it into the SmappeeConnect.

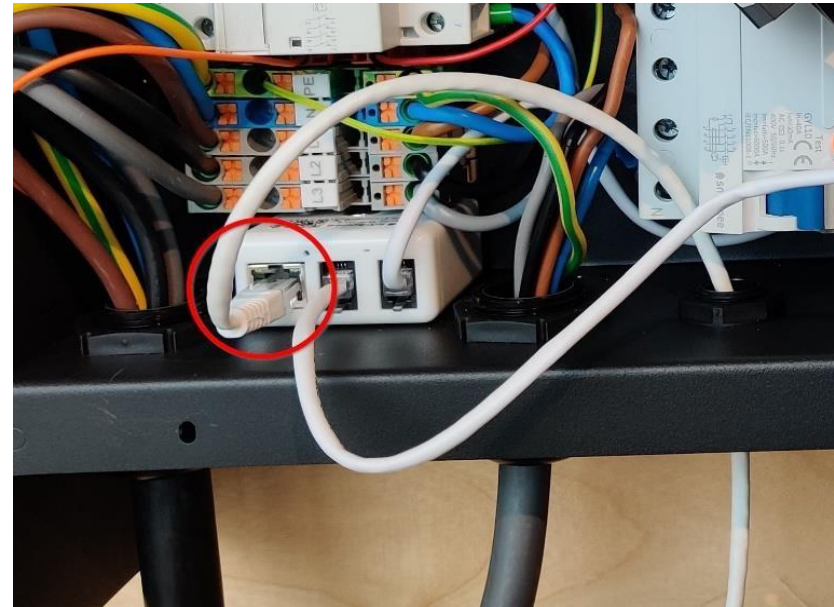
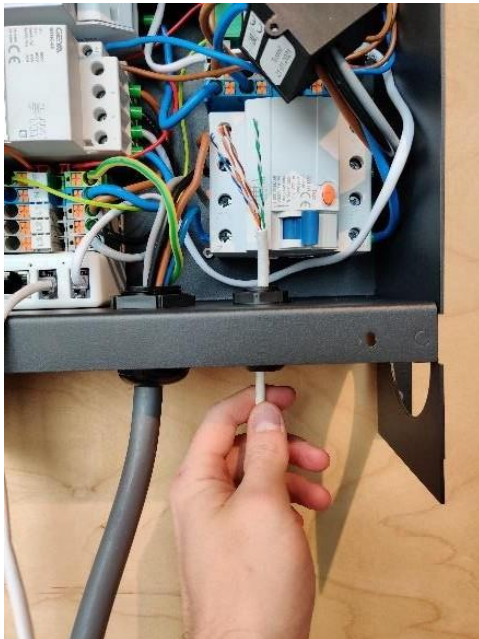

Step 2. Installation and activation

EV Wall Business

Switching on the EVWall

- Check all connections are secure and power-up the power supply of the EVWall.
- Check the status LEDs:
 - Connect – Blue flashing
 - RCM – ON light active
 - MID-meter is powered on
 - Charging controller: green flashing light (1 x per 3 seconds)

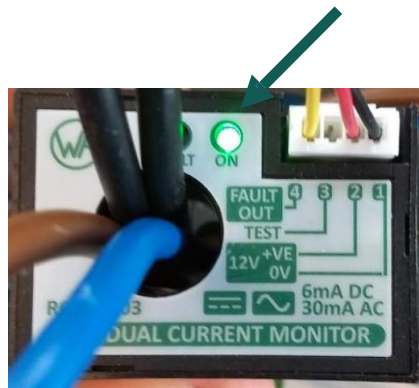
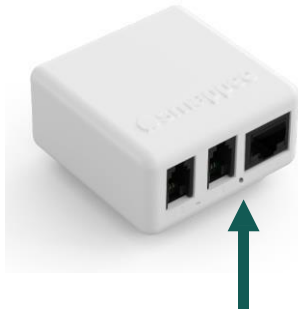

Step 2. Installation and activation

EV Wall Business & EV Base

Download the Smappee Smappee Energy Monitor app (iOS or Android) on your mobile device.

Login to the Smappee App with the corresponding Smappee username or create a new user account.



Architecture – Location site

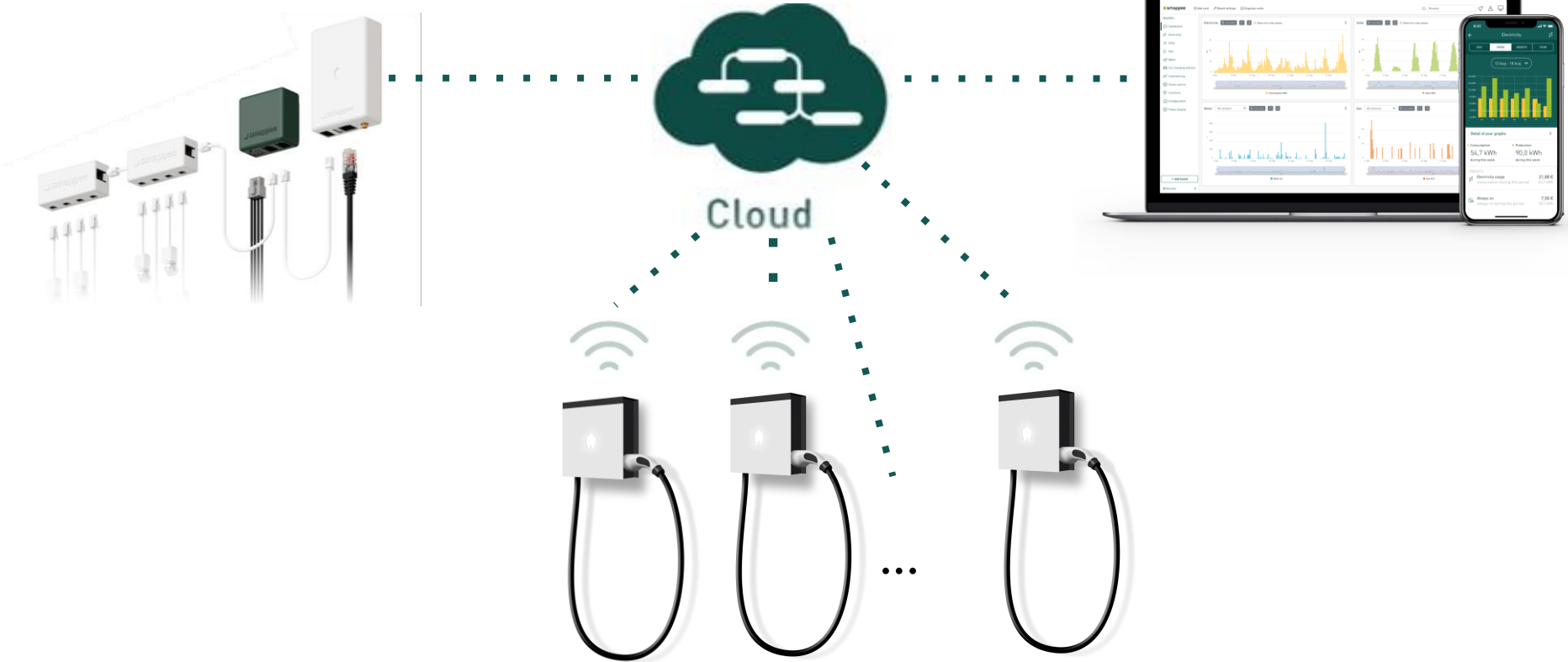

Architecture – Location site

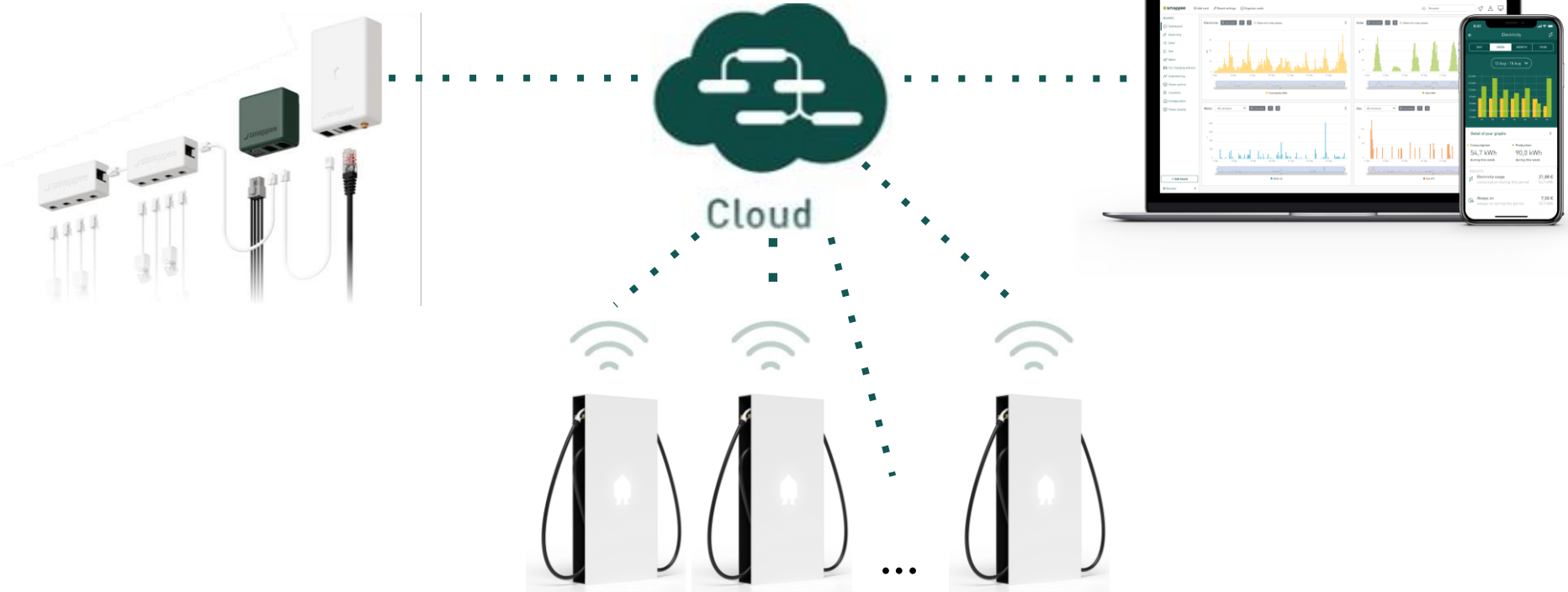

Architecture – Location site

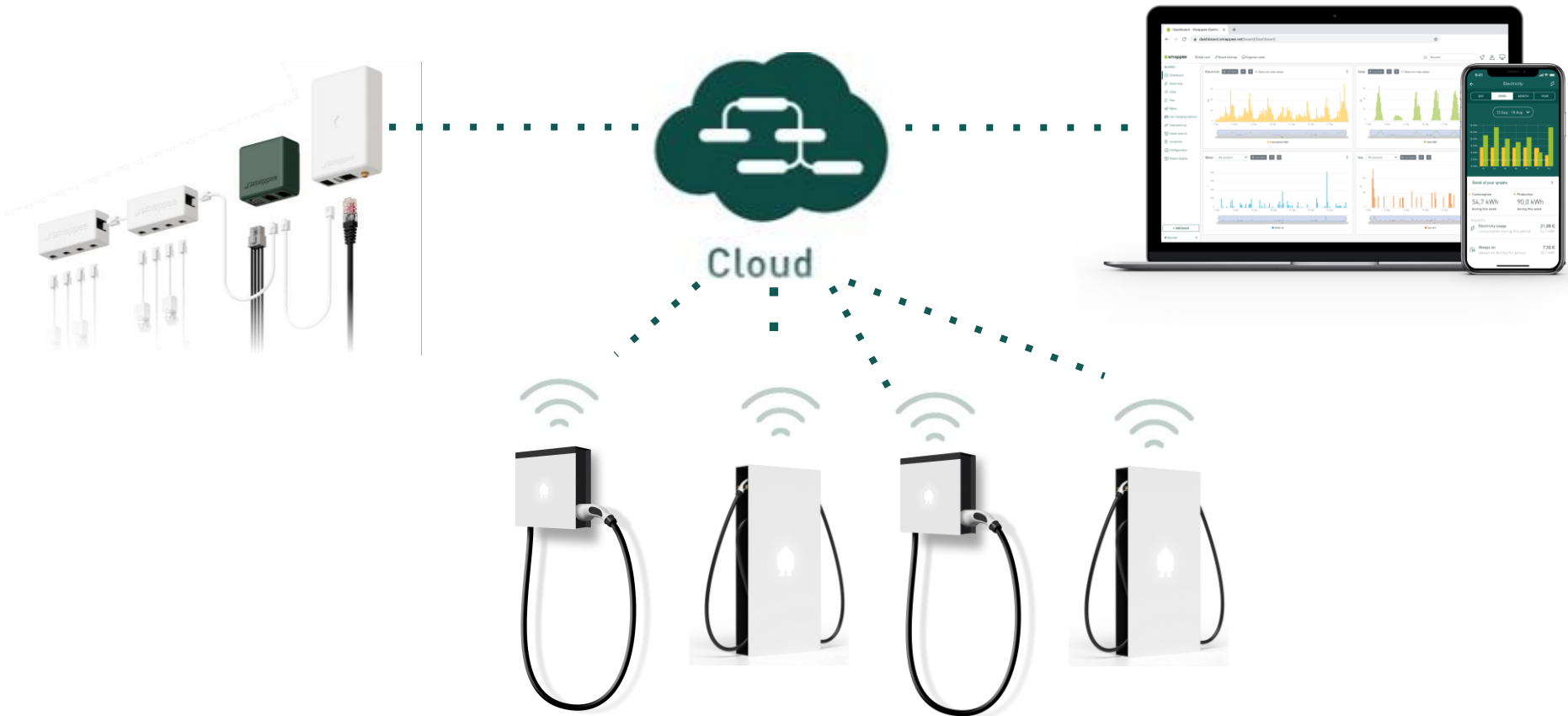

Step 2. Installation and activation

EV Wall Business & EV Base

Before proceeding:

Is Overload Protection & Solar Optimization required?

Yes: Is the Smappee Energy monitor already installed on-site?

- Yes: Install EVBase(s) under the existing Smappee location.
- No: Create a new location to install your first EVLine. Add other EVLine(s) under that Smappee location.

No: Create a new location to install your first EVLine. Add other EVLine under that location.

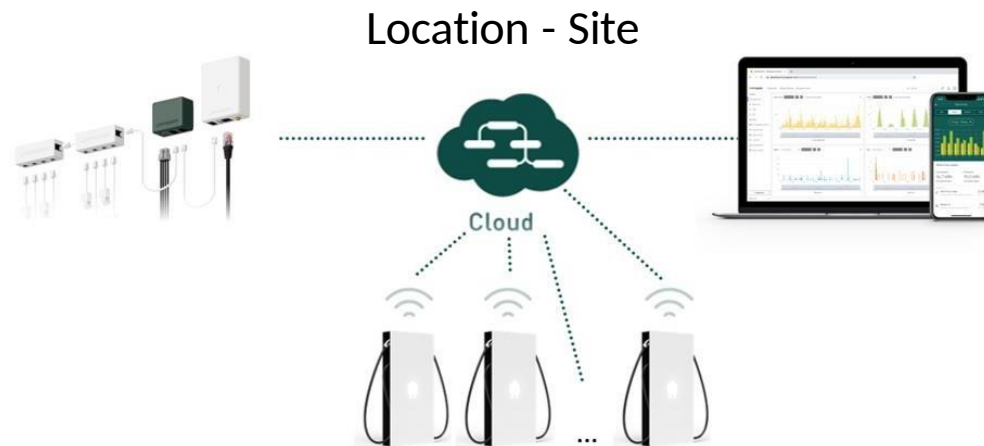

Step 2. Installation and activation

EV Wall Business & EV Base

Is Overload Protection & Solar Optimization required?

Yes: Is the Smappee Energy monitor already installed on-site?

- Yes: Install EVBase(s) under the existing Smappee location.

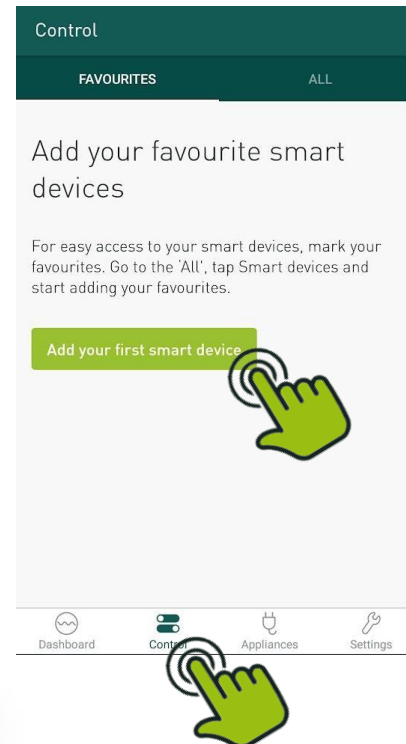
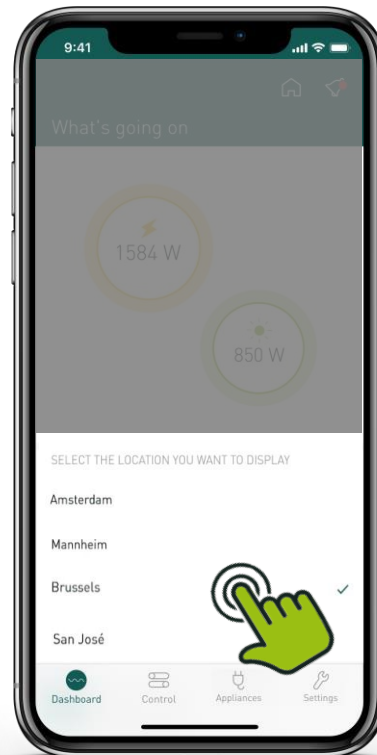
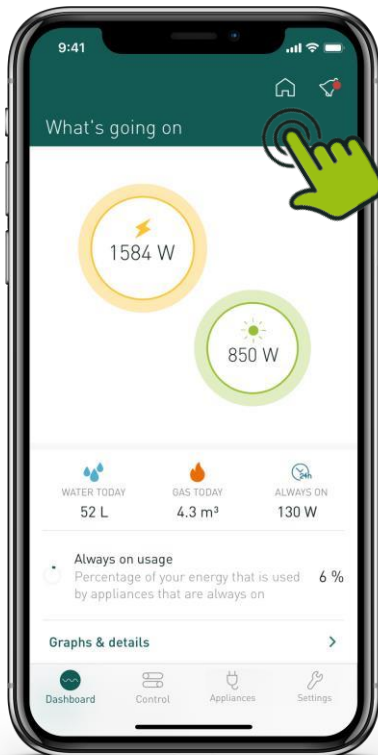

Which smart device would you like to connect?

SMAPPEE CONTROL DEVICES

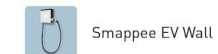
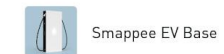

Step 2. Installation and activation

EV Wall Business & EV Base

Is Overload Protection & Solar Optimization required?

No: Create a new location to install your first EVBase. Add other EVBases under that location.

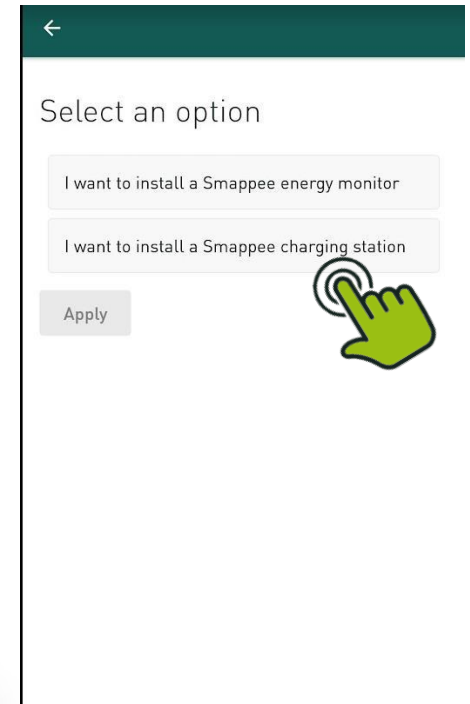
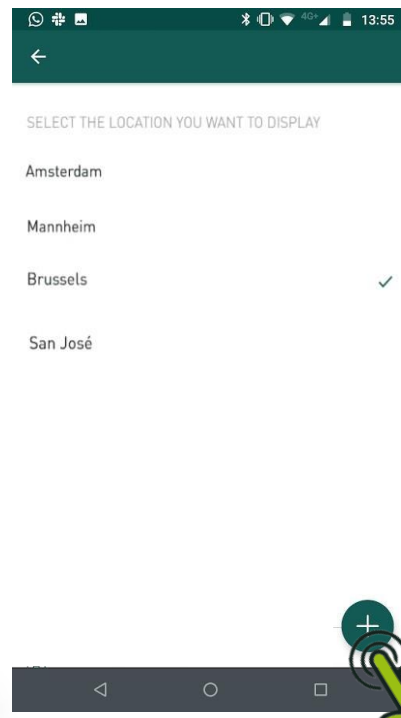

Step 2. Installation and activation

EV Wall Business & EV Base

Follow the steps shown in the mobile app.

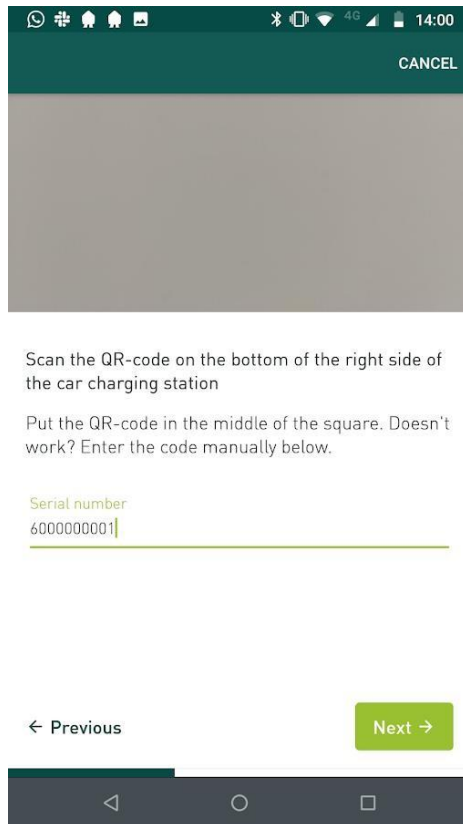

The identification label of your charging station is located under the top cover of connector 1.

S/N EVLine: 6xxxxxxxxx



Step 2. Installation and activation

EV Wall Business & EV Base

Follow the steps shown in the mobile app.

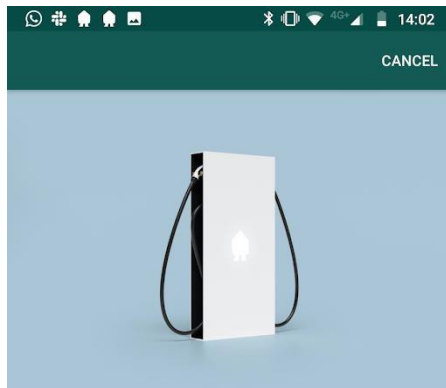

Let's name this Smappee EV Base

Tip: name it after its location or number it logically. It will be easier to find it in the App.

The name of the car charging station

EVBase 1

← Previous

Next →

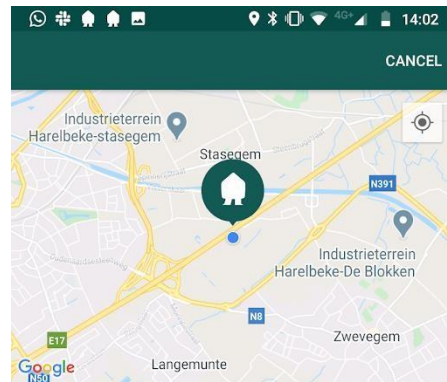

Pin the location of your Smappee EV Base

Smappee needs to know the exact location of the charging station that you're installing. This is important for the time zone settings and to get a correct overview of your car charging station park.







Long press on the pin and drop on the map.

← Previous

Next →



What colour does your Smappee EV Base emit?

-  Blue flashing  >
-  Blue continuous >
-  Green pulsing >
-  Green continuous >
-  Red >
-  No light >

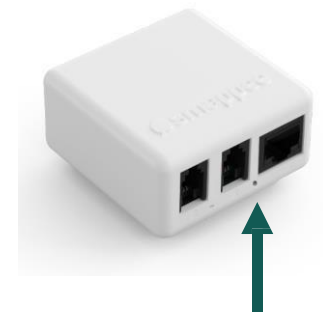

Step 2. Installation and activation

EV Wall Business & EV Base

Follow the steps shown in the mobile app.

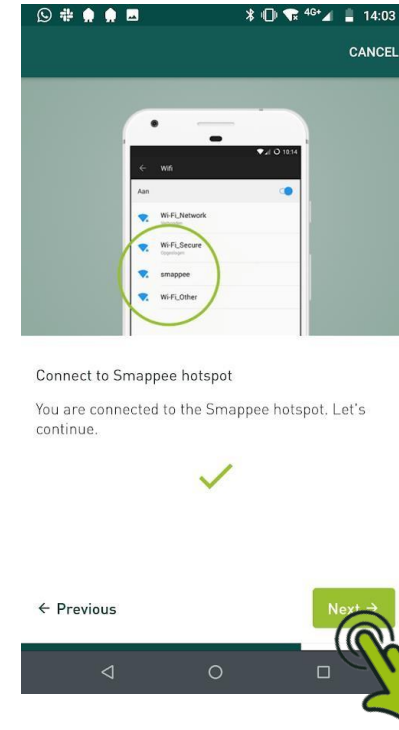
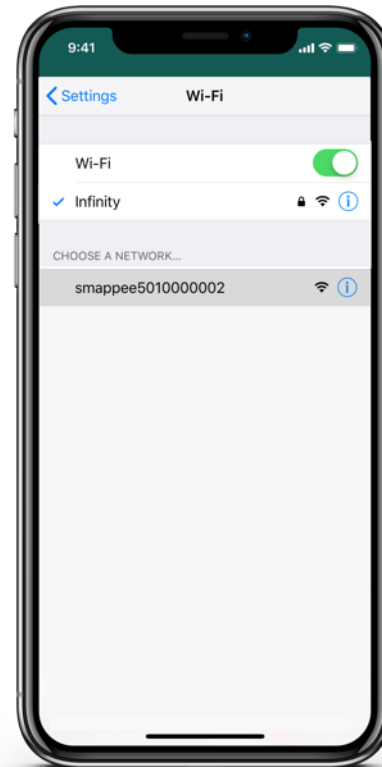
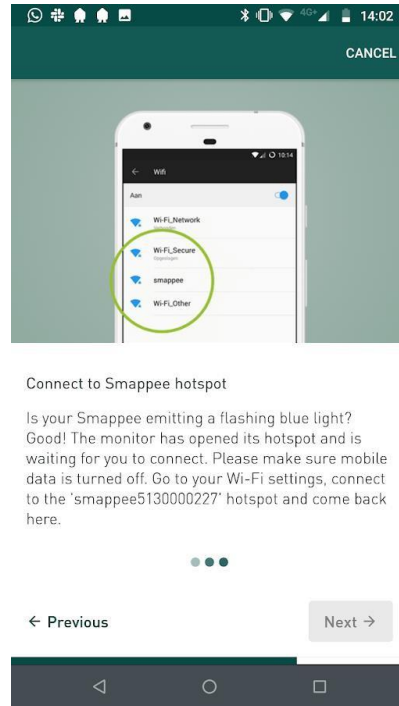
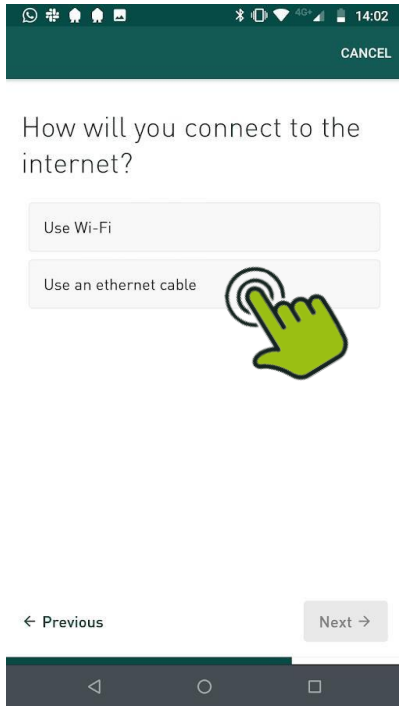

Step 2. Installation and activation

EV Wall Business & EV Base

Follow the steps shown in the mobile app.



Your phone is reconnected



Your phone is reconnected to a working Wi-Fi network. Let's continue.



What colour does your Smappee EV Base emit?

- Blue flashing >
- Blue continuous >
- Green pulsing >
- Green continuous >
- Red >

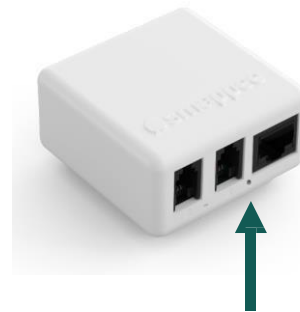

Activation complete



You have successfully completed all steps of the Smappee monitor activation flow.

← Previous

Next →



Step 2. Installation and activation

EV Wall Business & EV Base

Follow the steps shown in the mobile app.

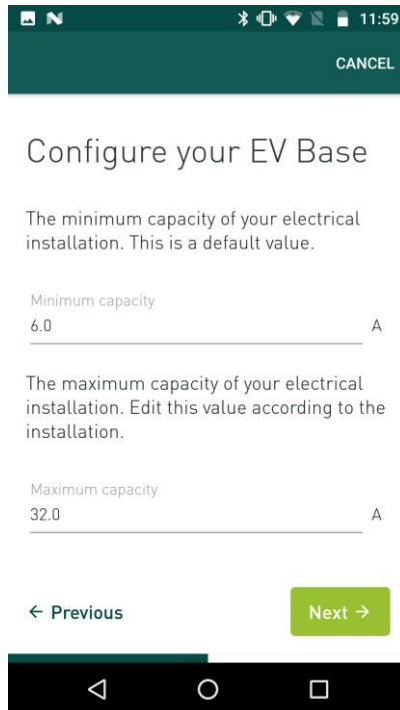

Configure your EV Base

The minimum capacity of your electrical installation. This is a default value.

Minimum capacity
6.0 A

The maximum capacity of your electrical installation. Edit this value according to the installation.

Maximum capacity
32.0 A

← Previous Next →

Minimum 6.0 A is the industry standard for lowest charging power without the car stopping the charge (leave as is).

Maximum: the maximum current the charge point can provide



Settings are applicable to both connectors & can be changed later through App & Dashboard

Step 2. Installation and activation

EV Wall Business & EV Base

To add a second EVLine to the same location

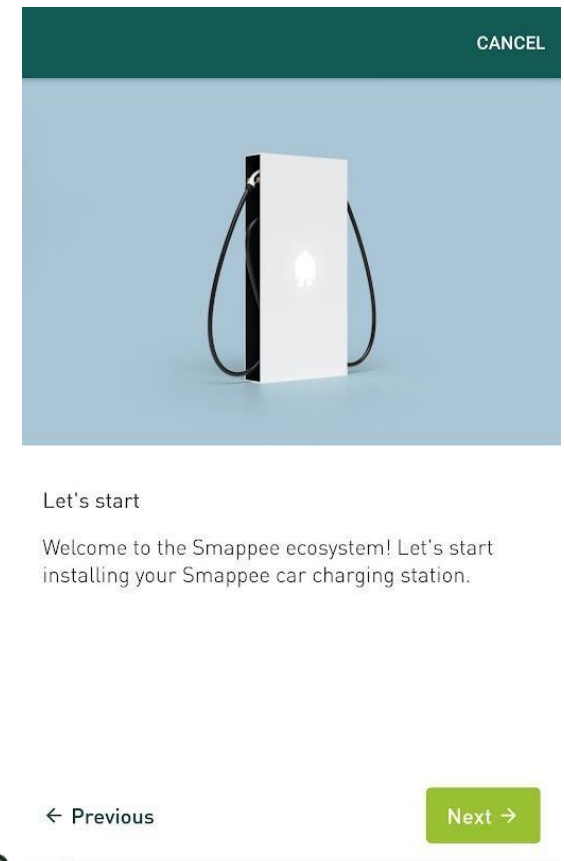
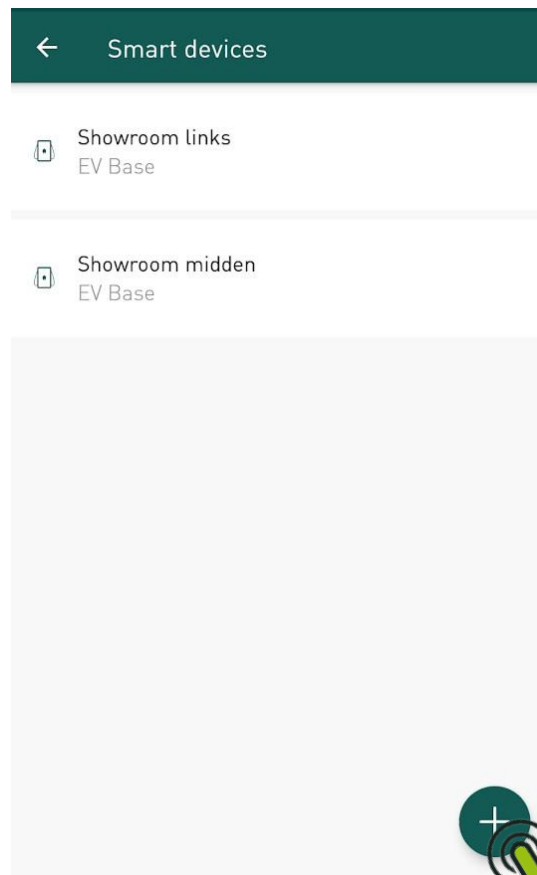
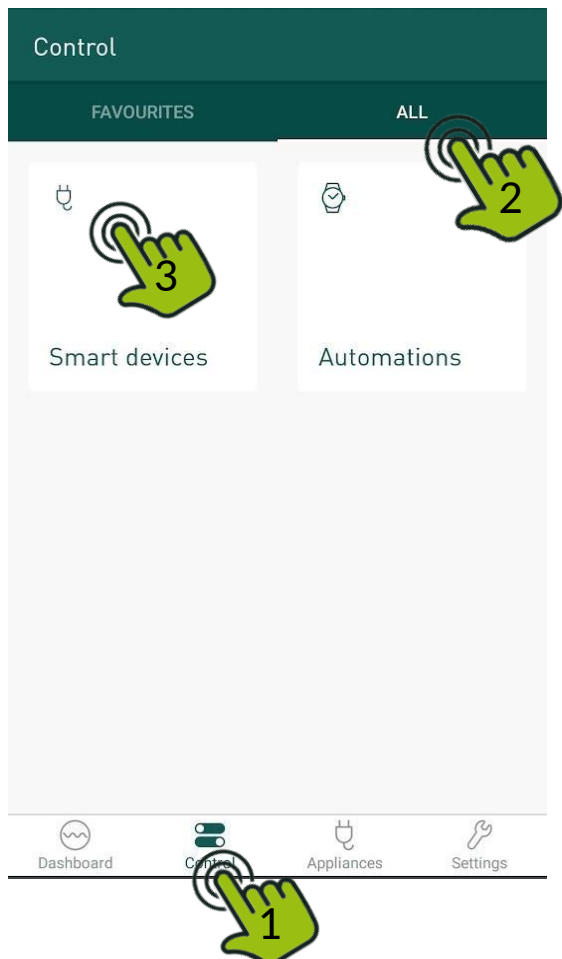

Step 2. Installation and activation

EV Wall Business & EV Base

To edit settings of installed EVLine(s)

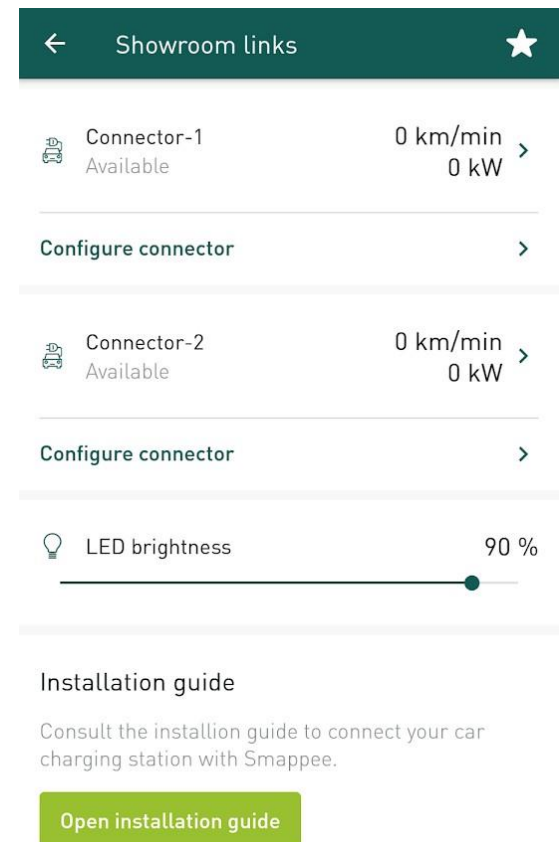
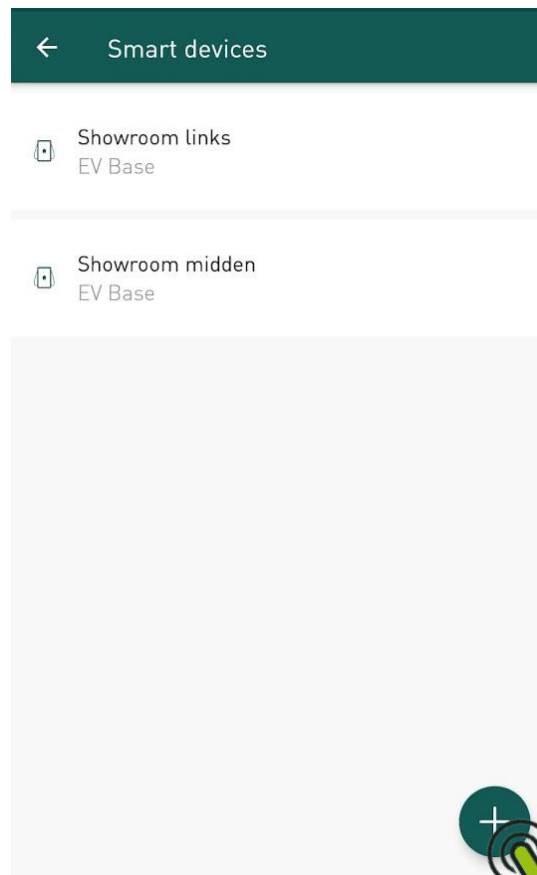
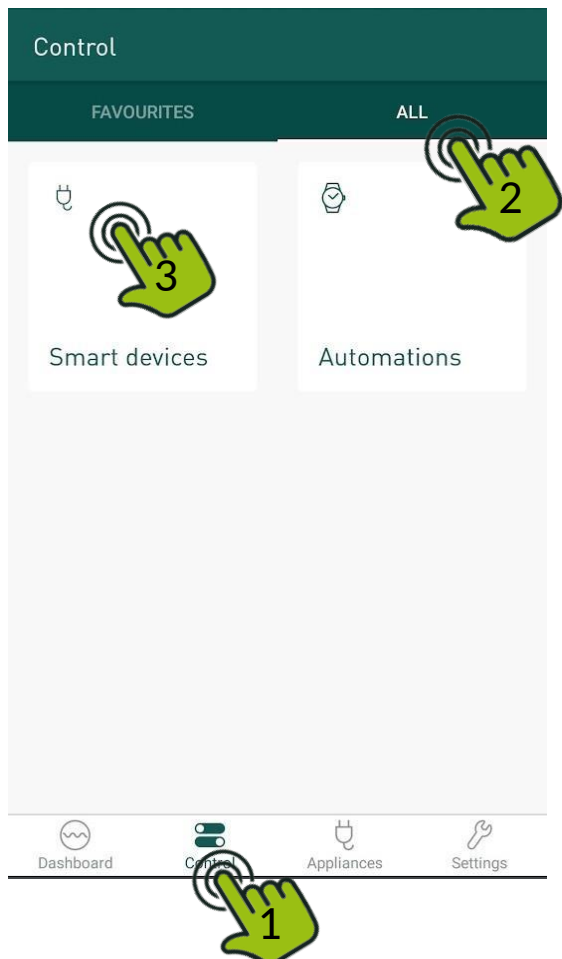

Step 2. Installation and activation

EV Wall Business & EV Base

To edit EVLine Hardware related items (replacement)

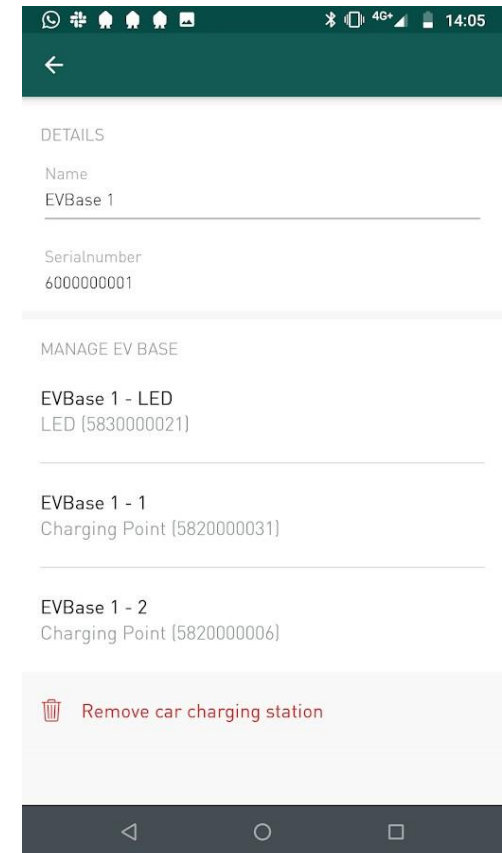
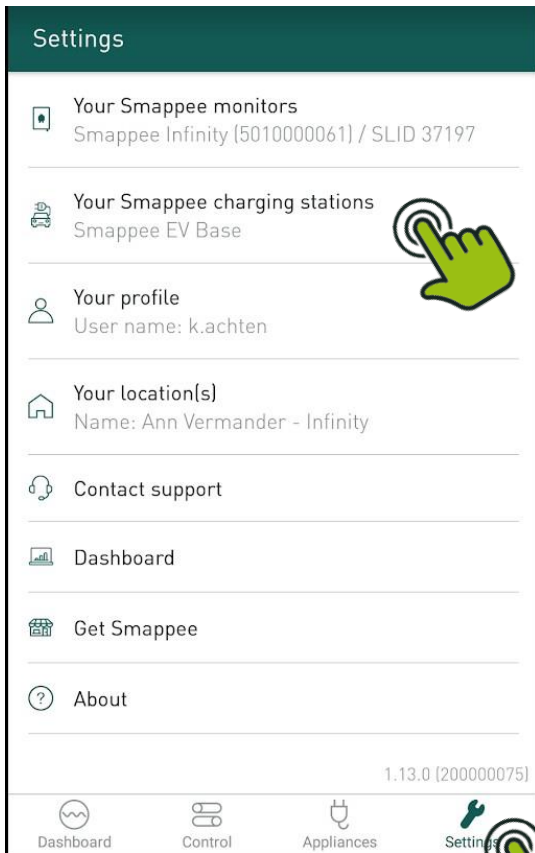

Step 2. Installation and activation

EV Wall Business



Closure

- Mount the front plate into position
- Connect the RJ10 cable to one of the B ports of the PCB attached to the front plate.
- Mount the front plate to the housing and secure with 2x M4 nuts

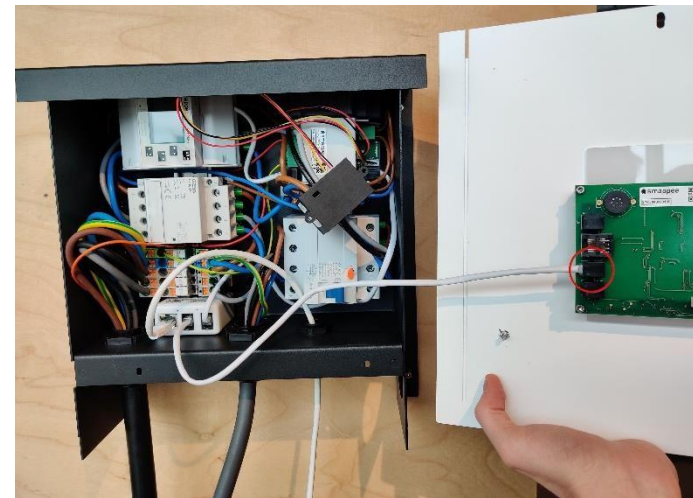

Be careful to connect the RJ10 cable to one of the B ports. Do not connect it to the A port.

The Ethernet cable should be connected to the Smappee Connect, not to the PCB attached to the front plate.



EV Wall
Home

Smappee EV Line

Home



Smappee EV Wall

- Energy and charging data
- Overload protection
- Solar optimisation

Infinity & Smart Charging Package included!

Business



Smappee EV Wall Business

- Charging data
- MID metering

Infinity & Smart Charging Package need to be purchased separately:

- Energy data
- Overload protection
- Solar optimisation
- Extension to 5 year warranty



Smappee EV Base

- Charging data
- MID metering

Infinity & Smart Charging Package need to be purchased separately

- Energy data
- Overload protection
- Solar optimisation
- Extension to 5 year warranty

Smappee EV Line

Home



Smappee EV Wall

- Energy and charging data
- Overload protection
- Solar optimisation

Infinity & Smart Charging Package included!

Use only for residential single EVWall installations.

EVWall (Home) can only be used for:

- Residential installations
- New installations that have no Infinity installed yet.
- For single EVWall unit installations (1 connector)



If multiple EVWall (Home) unit are needed in residential environment, use the EVWall Business with separate Infinity.

EVWall (Home) does not support the use of Output module or other Infinity accessories (Switch, Gas & Water monitor, Input module)

EVWall (Home) can be extended with additional CT Hubs & CTs for metering.

EV Wall – *Home*

The EVWall comes in the package with the required Smappee Infinity components to be installed in the distribution panel to measure:

- Main feeder (total consumption)
- Solar production

EV Wall – Home

The EVWall comes in the package with the required Smappee Infinity components to be installed in the distribution panel:

Single Phase Edition

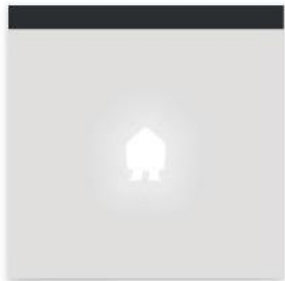

EV Wall



EV Wall mounting plate



EV Wall splitter



DIN mounting plate



Connect



Wall mounting plate



CT Hub



CT 50A x3



RJ10 cable
40 mm



RJ10 cable
150 mm



Bus termination plug



Screw & plug x3



Small screw x3

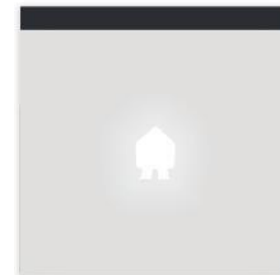

EV Wall



EV Wall mounting plate



EV Wall splitter



DIN mounting plate



Connect



Wall mounting plate



CT Hub



CT 50A x4



Solid Core
3-phase CT



Bus terminatic plug



RJ10 cable
40 mm



RJ10 cable
150 mm



Screw & plug x3



Small screw x3

EV Wall - Connection diagram (1P+N)

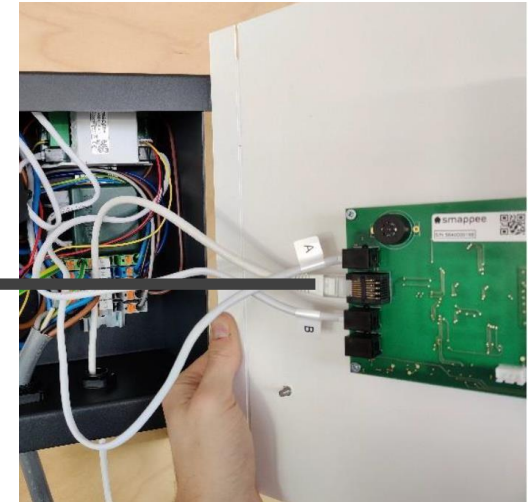
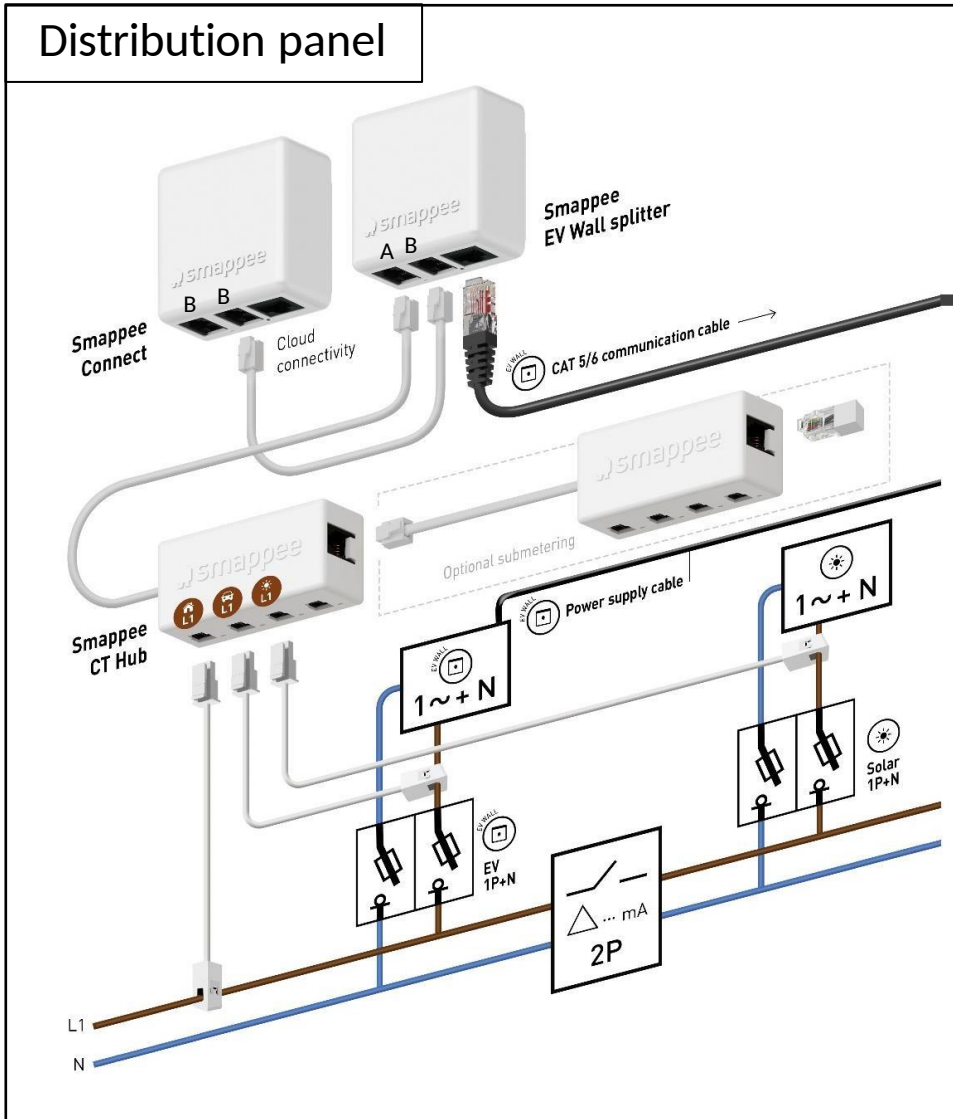

Step 2. Installation and activation

Place the EVWall in position

- Remove the front plate of the EVWall.
- Put away the front plate to avoid damaging the PCB-board attached to it.
- Attach the EVWall housing to the mounting plate using supplied M4 2.5mm HEX screws (3 pieces).

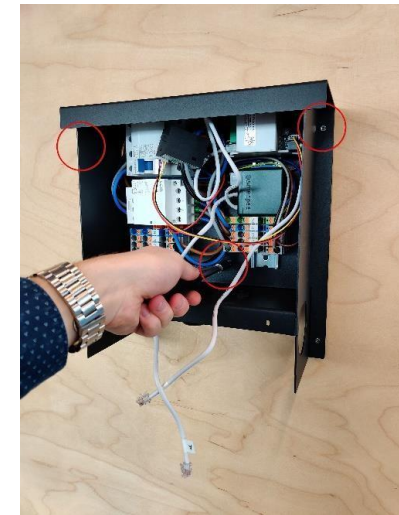
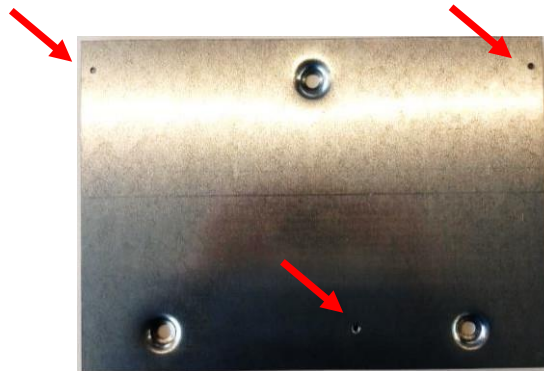
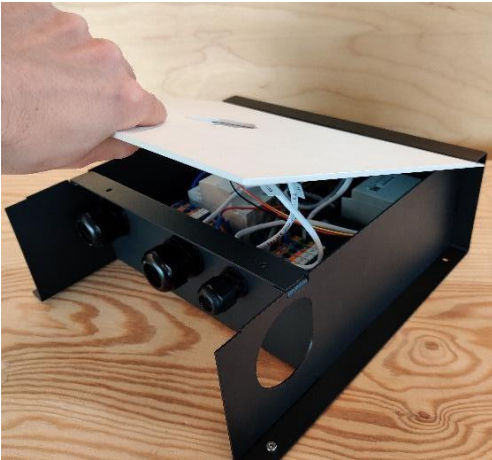

Slide the power cable through the cable glands first before mounting the EVWall housing the mounting plate.

Step 2. Installation and activation

Power supply connection & internet connectivity

- Mount the power cable through the central cable gland (M32)
- Connect each supply cable to the connecting block and respect the phase-numbering:
 - L1, L2,L3,N to Diff. Type A
 - Ground (6 mm²) to connecting block

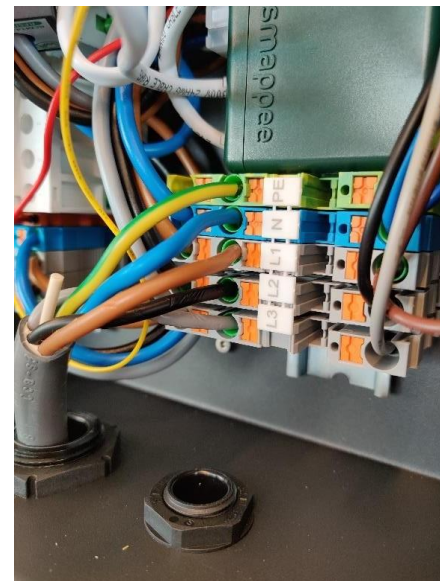
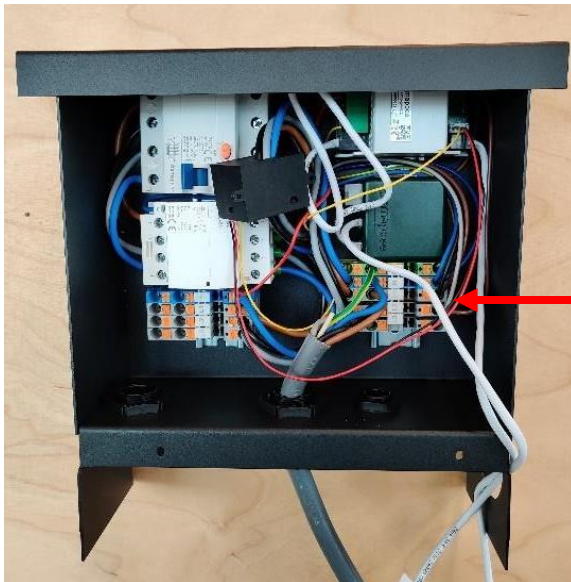

Step 2. Installation and activation

	Brown - L1
	Black - L2
	Grey - L3
	Blue - Neutral

Mount fixed cable

- Through left cable gland:
 - Tighten the Cable gland
 - Add cable tie for mechanical strain relief (supplied)

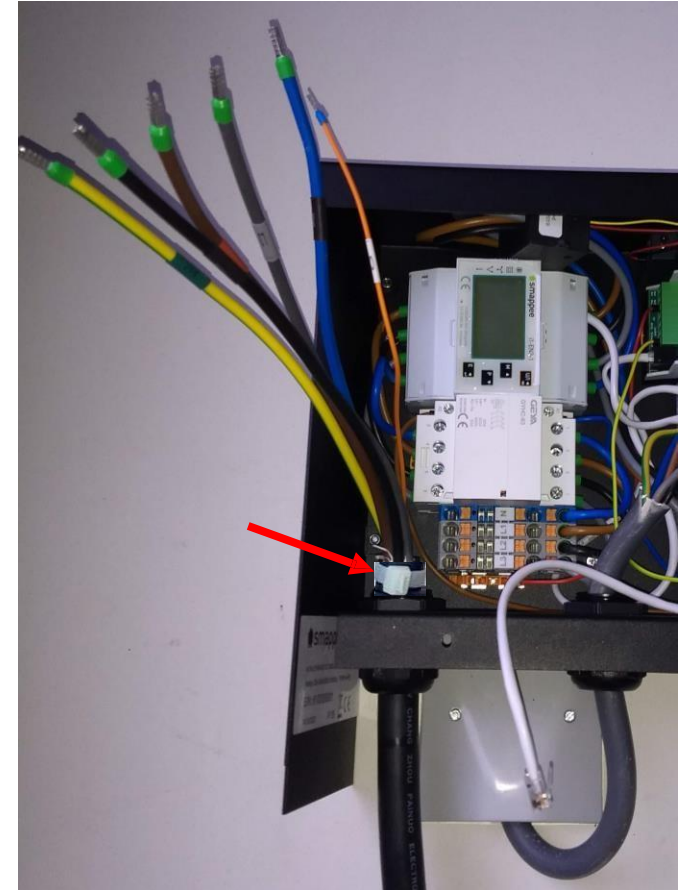

Fixed cable can be shortened to the appropriate length and have ferrules added (not included in the package).

Step 2. Installation and activation

	Brown - L1
	Black - L2
	Grey - L3
	Blue - Neutral

Mount fixed cable

- Through left cable gland:
 - Tighten the Cable gland
 - Add cable tie for mechanical strain relief (supplied)
- All wires need to be connected to connector block
 - L1, L2, L3, N and ground (6 mm²)
 - CPcable (1,5 mm³) orange

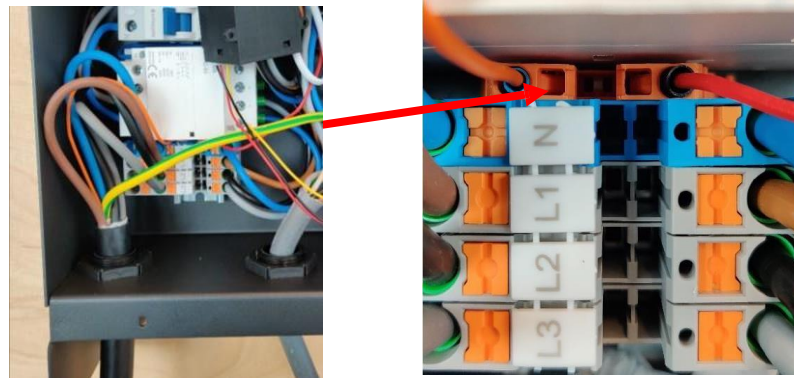

Step 2. Installation and activation

	Brown - L1
	Black - L2
	Grey - L3
	Blue - Neutral

Power supply connection & internet connectivity

- Add the CAT.5/6 communication cable (internet connection) through right cable gland (M20)
- Attach an RJ45 connector to the Ethernet cable after feeding it through the cable gland. Plug it into the SmappeeConnect.

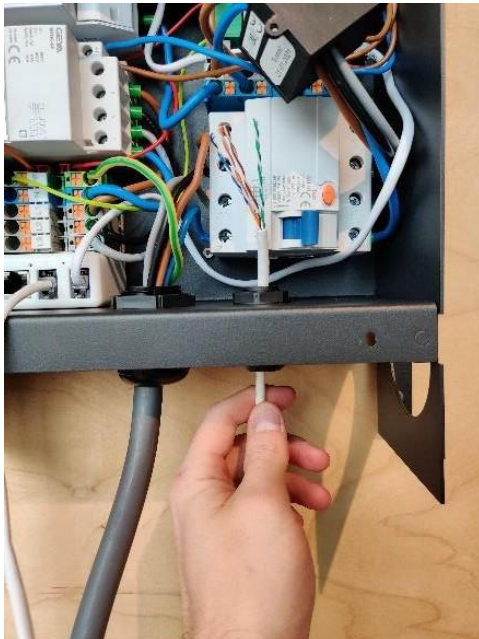

Step 2. Installation and activation

Switching on the EVWall

- Check all connections are secure and power-up the power supply of the EVWall.
- Check the status LEDs:
 - Power Box – Pulsing 1x per 3 seconds
 - Both RCM – ON light active
 - Charging controller: green flashing light (1 x per 3 seconds)



Step 2. Installation and activation

Closure

- Mount the front plate into position by connecting the RJ10 cables and Cat 5/6 cable to the PCB attached to the front plate.
- Pay attention to stickers and connect each cable to the corresponding input (A&B).

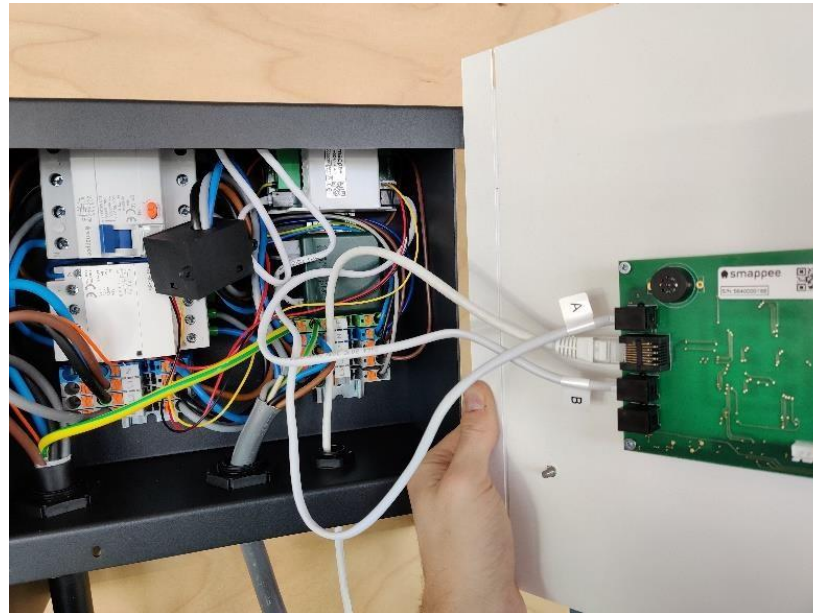

All communication cables must be attached to the front panel before powering the EV Wall. The EV Wall should also be closed.

EV Wall – *Home*

IMPORTANT notes for 3P (3*230V) – Delta

- In case an isolation transformer is used, converting 3*230V (3P) to 3*400V (3P+N), an additional Power Box needs to be purchased and installed in the distribution panel.
- In the EVWall (Home) unit, the RJ10 data cables on the in-built Power Box need to be disconnected.

IMPORTANT notes for 3P (3*230V) – Delta

Some EV-vehicles are not compatible with 3P (3*230V) grid connection due to an in-built security in the EV.

- Type 1: One of the phases is in the low voltage cabin connected to earth. The voltage between ground & 1 of the phases is 0 volts.
- Type 2: None of the phases are connected to earth. The voltage between each phase and earth is 130V.

Check prior to the EVWall installation the type of Delta Topology by measuring the voltage between the phases and ground.

- If 0 Volts => Type 1: all EV cars can charge. The phase that provides 0V needs to be connected to the Neutral of EVWall power supply.
- If 130V Volts (not 0V)=> Type 2:
 - If a specific EV is to be charged, check with the EV manufacturer if compatible with this setup.
 - If a specific EV is not compatible or multiple EV-types need to be charged, an isolation transformer needs to be installed.



Dynamic loadbalancing with or without an isolation transformer for the power supply of the EVWall is supported. (cfr. Type 2 – Delta installation).

EV Wall - Home

IMPORTANT notes for 3P (3*230V) – Delta
 In case an isolation transformer is used

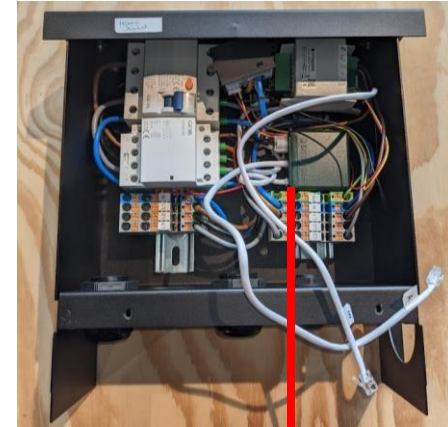

Disconnect both the RJ10 data cables out of the in-built PowerBox

An additional Power Box needs to be installed in the distribution panel.

Distribution panel

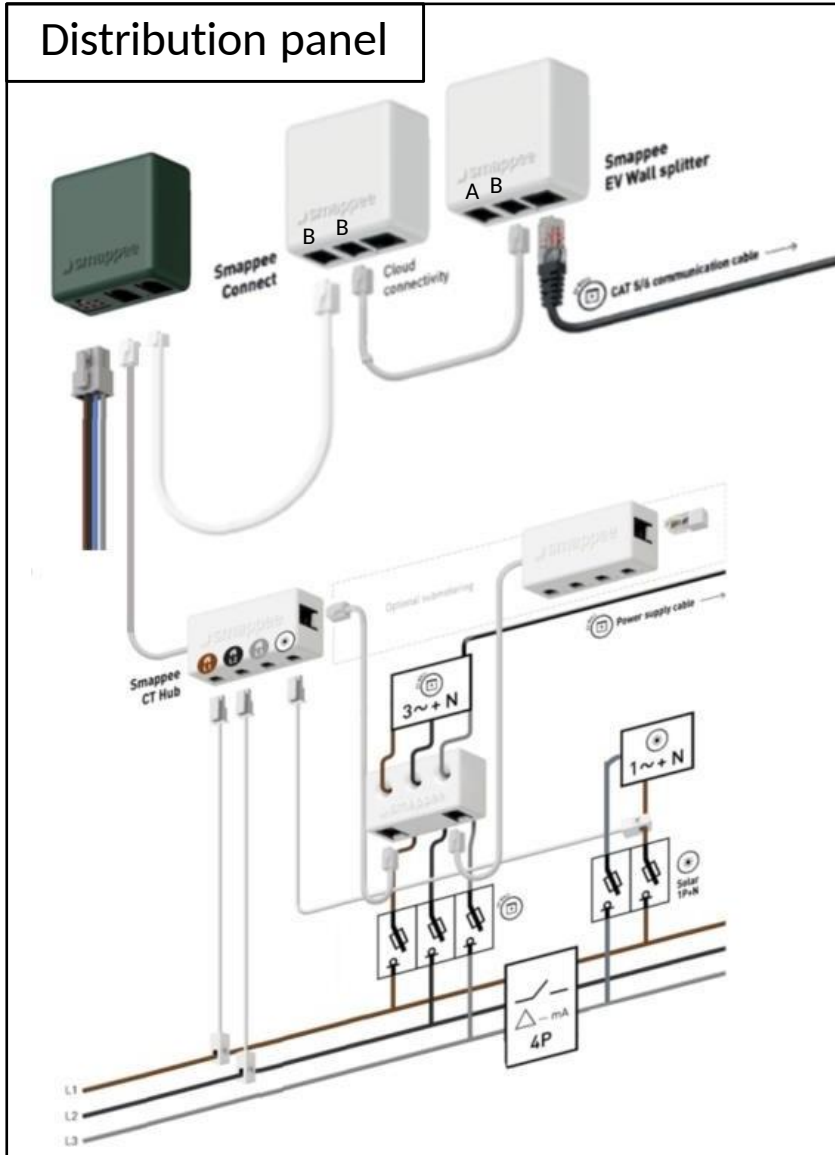

Step 2. Installation and activation

IMPORTANT notes for 3P (3*230V) – Delta





Power supply connection

- In case the charge point is connected to a 3x230V with isolation transformer is used, connect the power supply cables as follows:
- EVLine is connected as a single phase (1P):

EVLine power supply cable
from distribution cabinet

	Brown – L1
	Black – L2
	Grey – L3

EVLine power supply input

	Brown – L1
	Black – L2
	Grey – L3
	Blue – Neutral



3P (3 * 230V) – Delta

Important Notes:

- Grid always must be measured with L1 and L2.
- For 3-phase inverters, appliances or sub circuits always must be measured with clamps on L1 and L2.

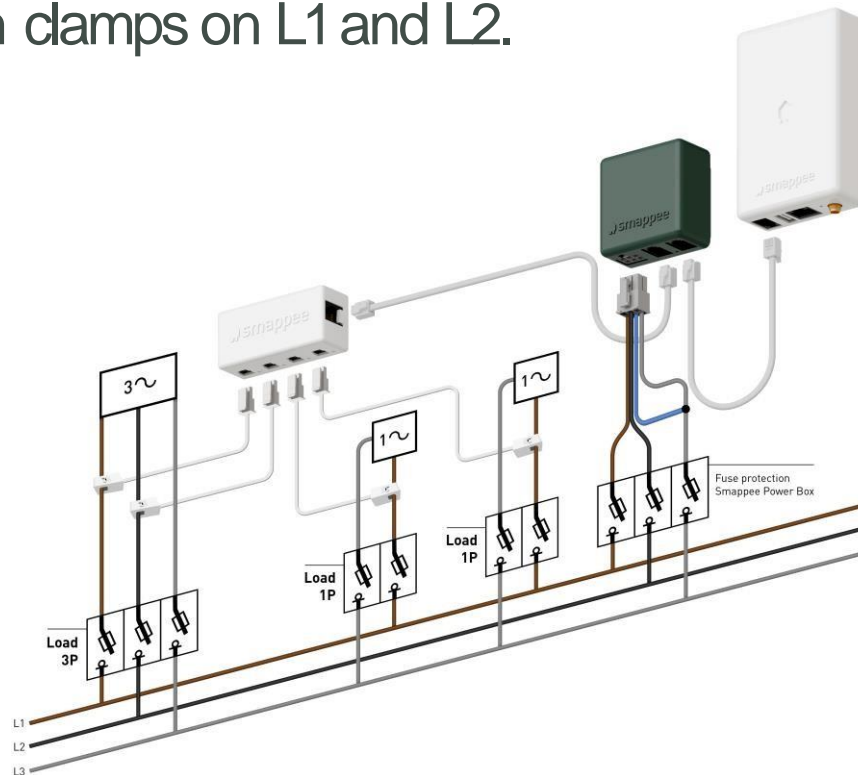

	Brown – L1
	Black – L2
	Grey – L3
	Blue – Neutral

3P (3* 230V) – Delta

	Brown – L1
	Black – L2
	Grey – L3
	Blue – Neutral

Important Notes:

- For 1-phase inverters or subcircuits, connect the clamp as follows:

Inverter or subcircuit	Connect the clamp around
L1 (brown) and L3 (grey, blue)	L1
L2 (black) and L3 (grey, blue)	L2
L1 (brown) and L2 (black)	L1

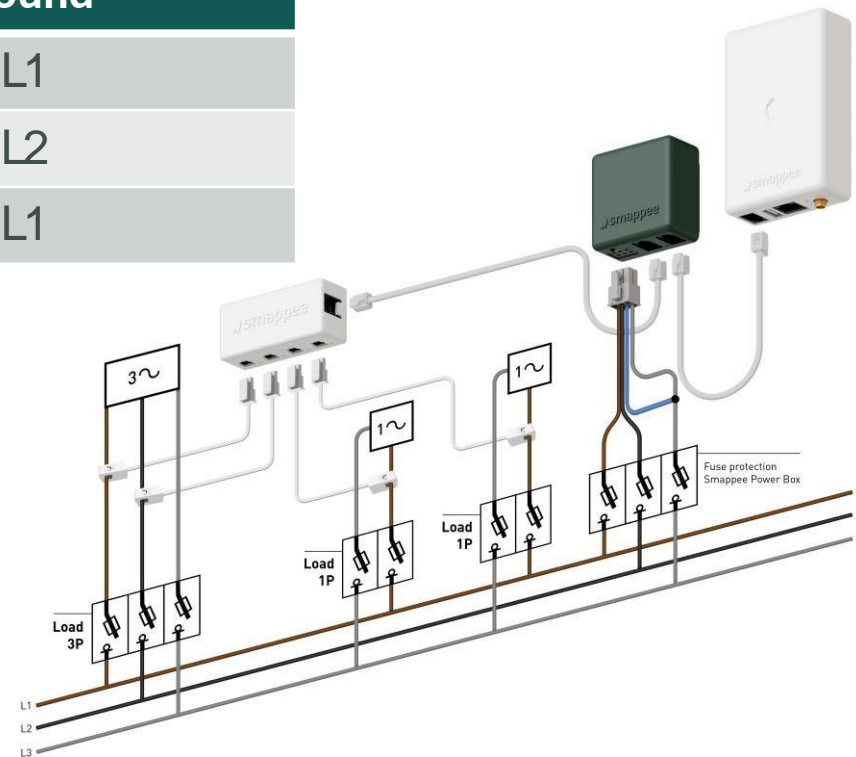

	Brown - L1
	Black - L2
	Grey - L3
	Blue - Neutral

3P (3* 230V) - Delta

Important Notes:

- For 1-phase inverters or subcircuits, connect the clamp as follows:

Inverter or subcircuit	Connect the clamp around	App - Phase Mapping
L1 and L3	L1	L1
L2 and L3	L2	L2
L1 and L2	L1	L3

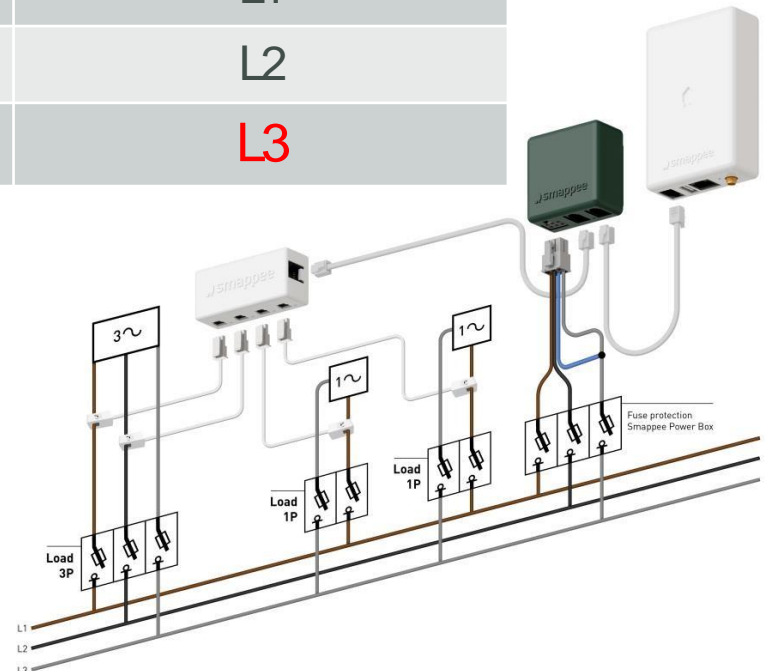

3P (3 * 230V) – Delta

Important! Phase mapping. Use a digital multi meter to determine by which phase the different loads are powered.

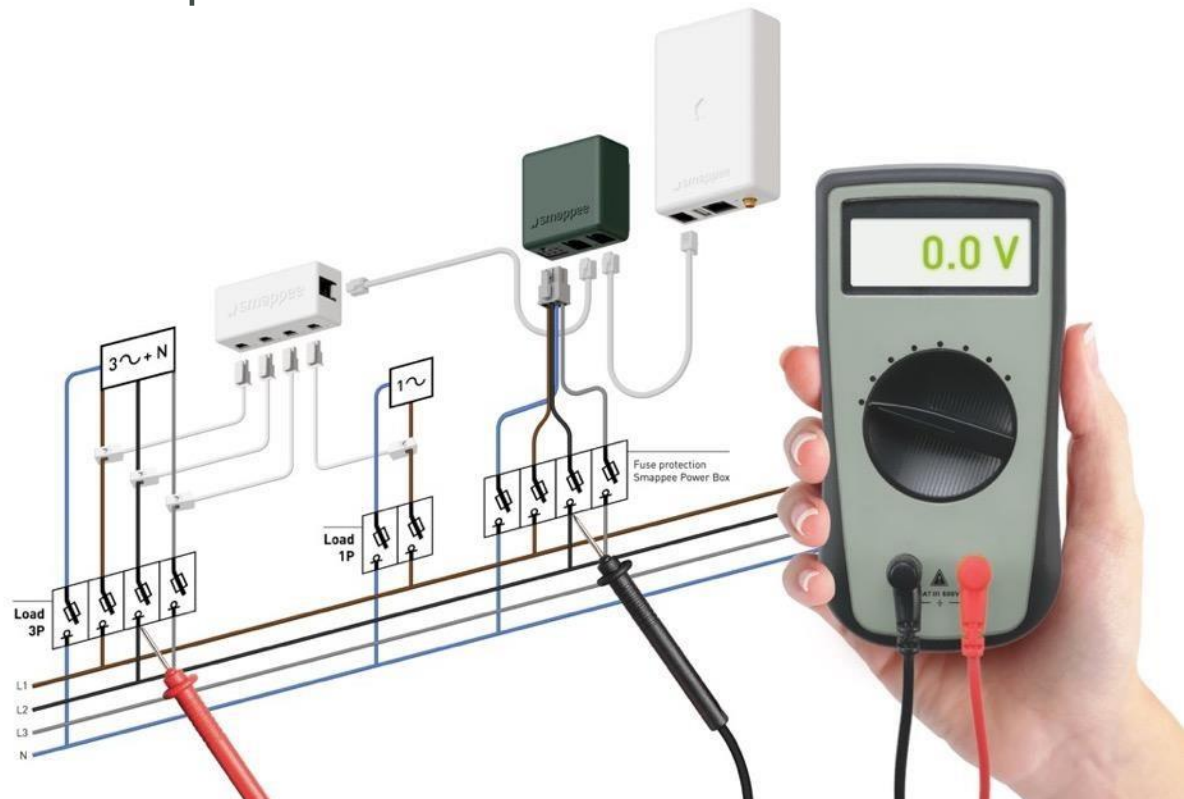
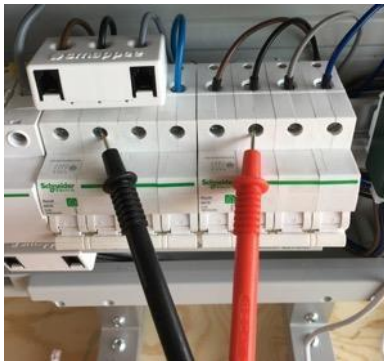

The colour code inside the fuse box and/or phase numbering can be false.

Step 2. Installation and activation

Download the Smappee Smappee Energy Monitor app (iOS or Android) on your mobile device.

Log in to the Smappee App with the corresponding Smappee username or create a new user account.

Follow the procedure in the mobile app



TIP: Changes to standard load configuration

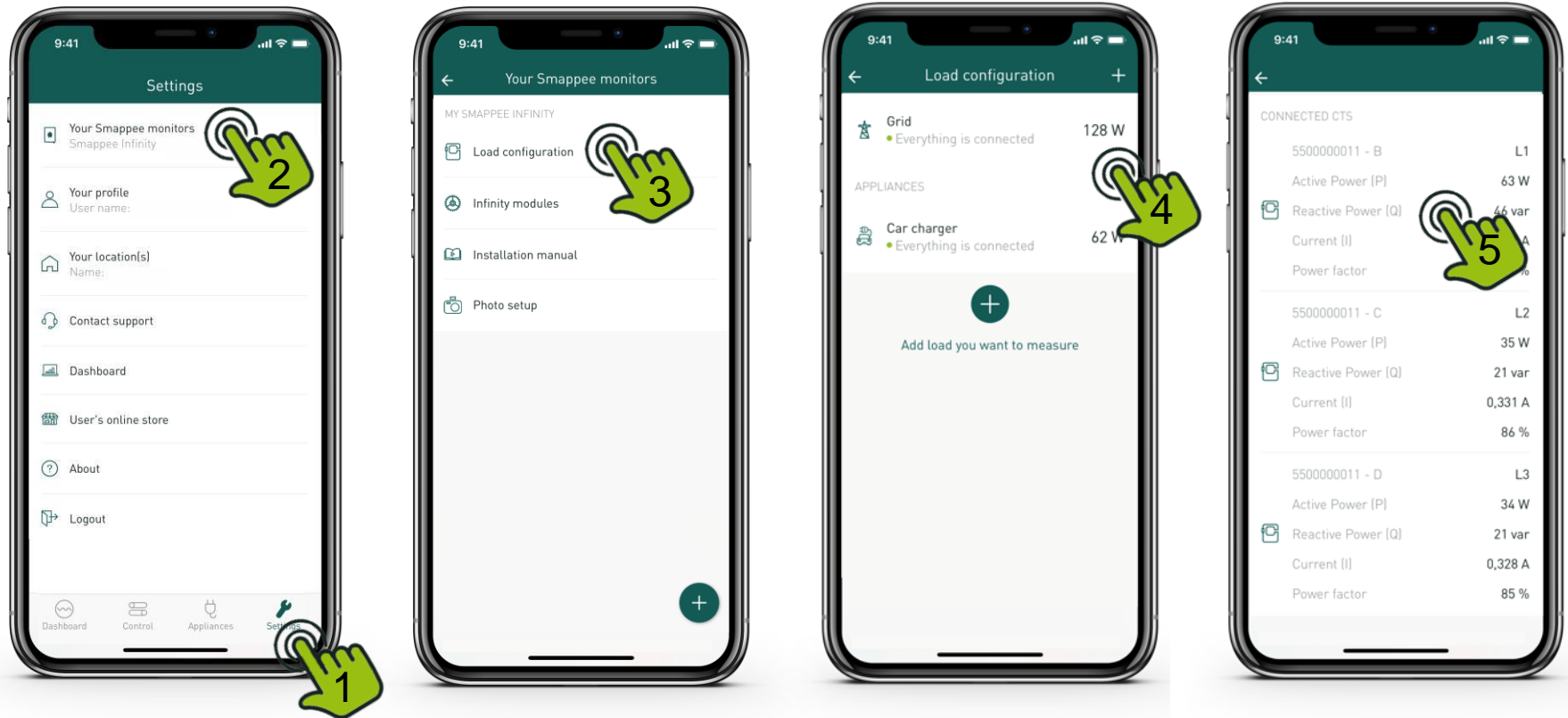

Providing End User Access

Sharing Smappee location with end customer

Transfer location to end user

Installer – End user

After completing the installation procedure, the location needs to be transferred to the end user (location owner).

1. Ask the end user to install the Smappee Energy Monitor app (iOS or Android) on his mobile device.
2. Let the end user sign up for a new user name on his own mobile device

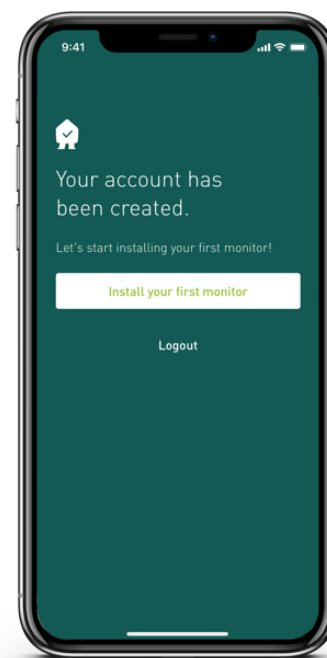
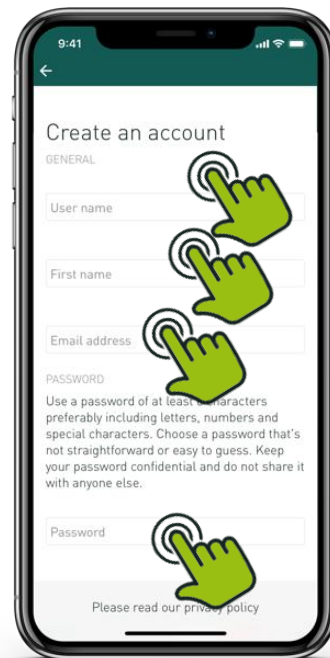

Step 7. Transfer location to end user

Installer – End user

3. The installer shares the location with the end user:

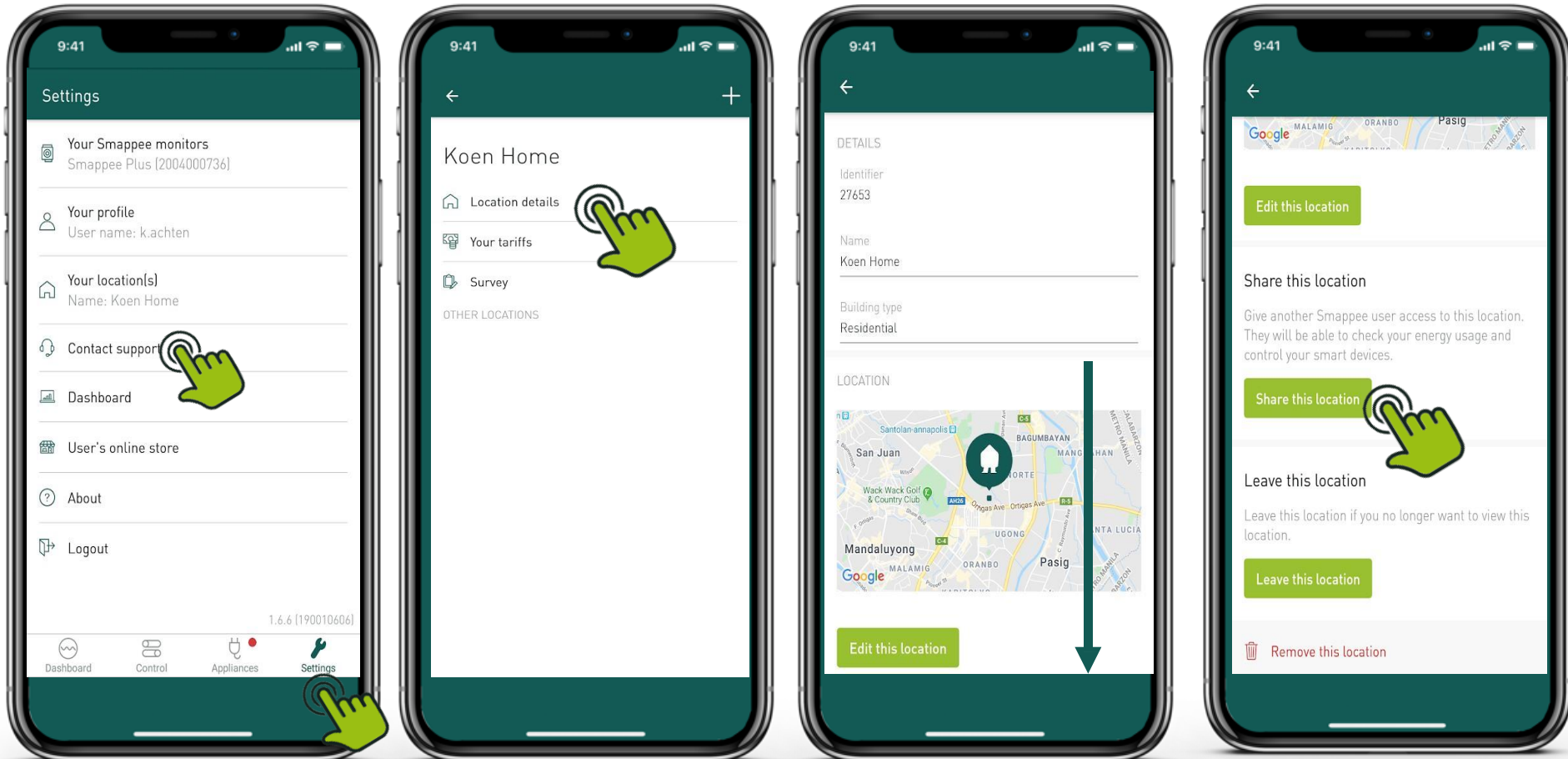

Step 7. Transfer location to end user

Installer – End user

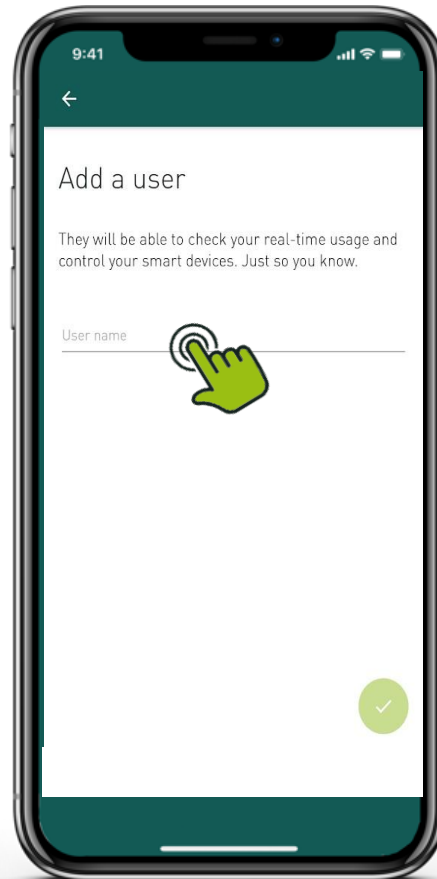
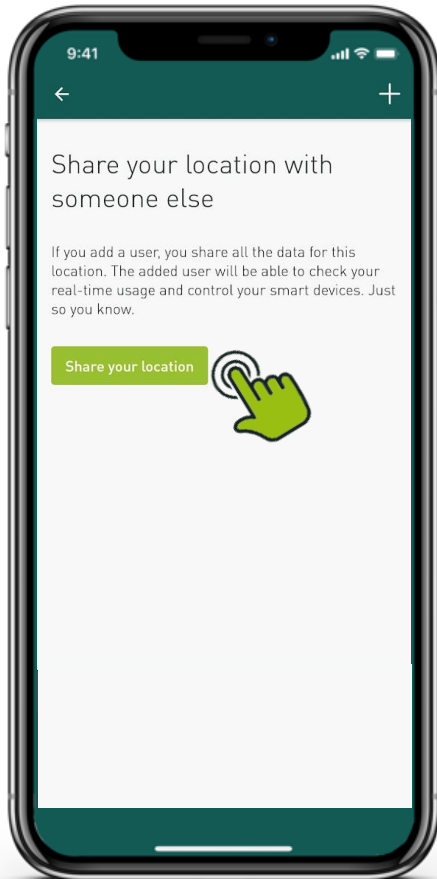

On the end user phone:

- Close the Smappee app and reopen. The location is now available in the app.
- Alternative: Logout from the Smappee app and login again

Fill in the Smappee user name
to share the location with

Step 7. Transfer location to end user

Installer – End user

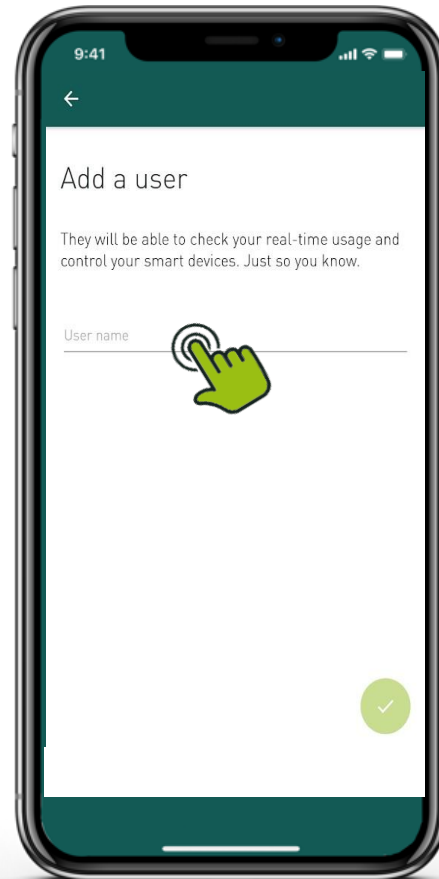
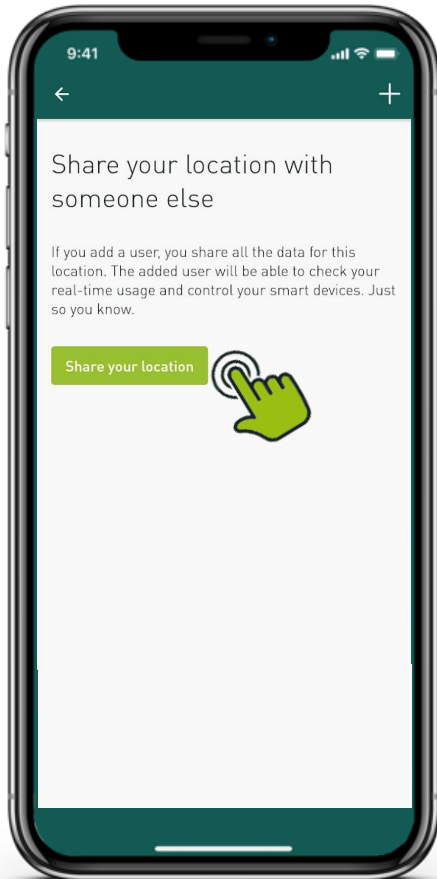

On the end user phone:

- Close the Smappee app and reopen. The location is now available in the app.
- Alternative: Logout from the Smappee app and login again

Fill in the Smappee user name
to share the location with

Step 7. Transfer location to end user

Installer – End user

IMPORTANT

- If end user may or does not have ‘edit’ rights, create a new user through Smappee Dashboard with ‘Read Only’ rights.
- User Management is available for Partner – Full Access account



Add user ×

Username

First name

Email

Password

 ×  

Password must have a minimum of 6 characters

Role

 ▼

User - Read-only

Interesting links & info

Interesting links for partners & installers

- Technical specifications and installation manuals: <https://www.smappee.com/smappee-manuals/>
- Help Center: <https://support.smappee.com/hc/en-gb>
- Blog: <https://www.smappee.com/blog/>
- FAQ: <https://www.smappee.com/faq/>

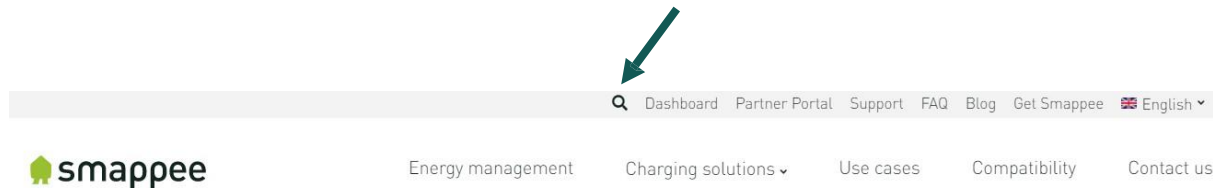

Use the search function on the Smappee website! (www.smappee.com)

Quiz Time!

We value your feedback!

Thank you!