



**GOODWE**  
*YOUR SOLAR ENGINE*



# GoodWe

## Inbedrijfstelling hybride omvormers

# Benodigdheden



GoodWe  
installatiehandleiding

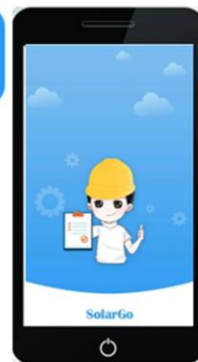

**SolarGo**  
Residentiële en C&I  
Instelling



**PV Master**  
Instelling voor energieopslag

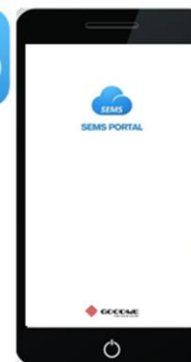

**SEMS**  
Monitoring



Gereedschapsset



AC/DC digitale Multimeter  
AC/DC Amp klem  
(aanbevolen)



Persoonlijke beschermende  
uitrusting



# GoodWe Apps



**SolarGo**  
Residentiële  
Commerciële & Industriële  
instelling

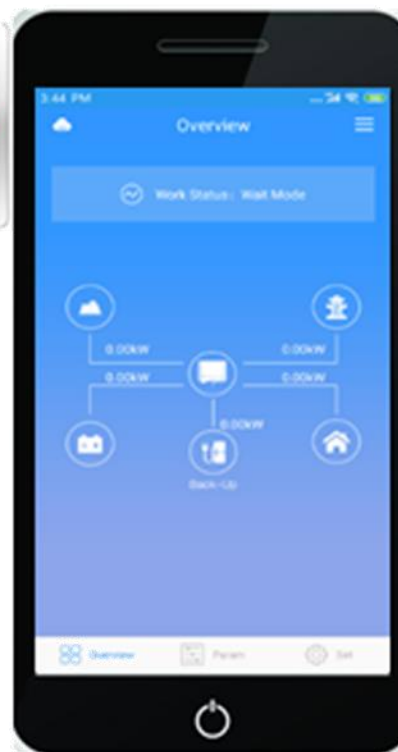

**PV Master**  
Instelling voor  
energieopslag/hybride  
ww = goodwe2010

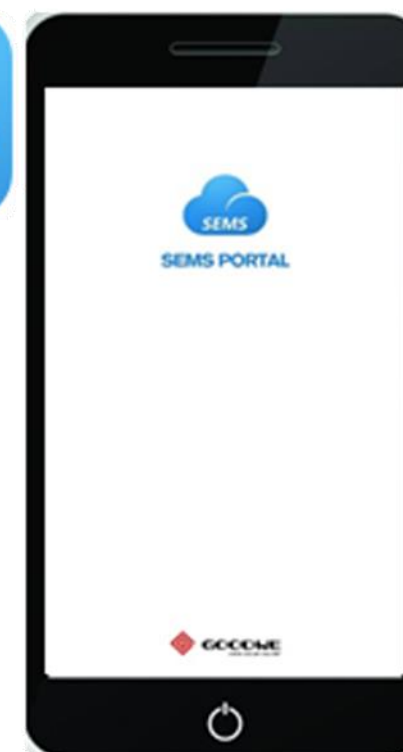

**SEMS**  
Monitoring



# Installatie check

# Inleidende checks

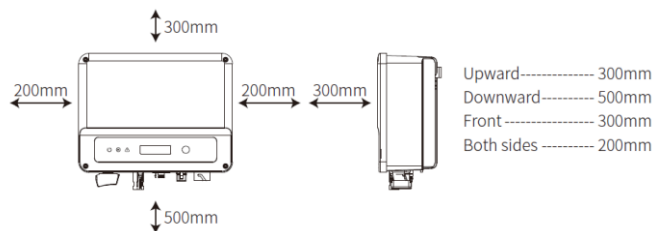

1. Zorg ervoor dat de omvormer is geïnstalleerd volgens de installatiehandleiding van GoodWe

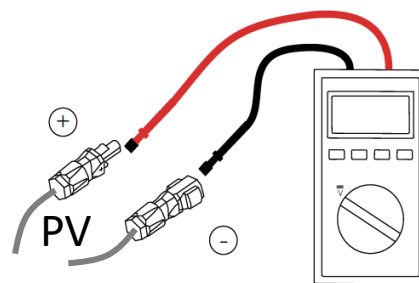

2. Controleer de polariteit van de strings die zijn aangesloten op de DC-ingang

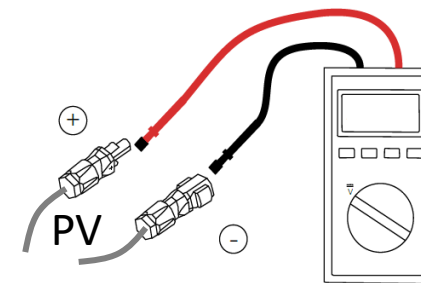

3. Meet de DC- spanning van de PV strings. Zorg ervoor dat het overeenkomt met de opstartspanning van de omvormer

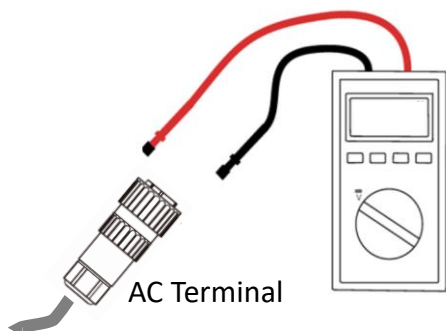

4. Meet de AC-spanning op de omvormer. Zorg ervoor dat deze binnen de toegestane limieten ligt

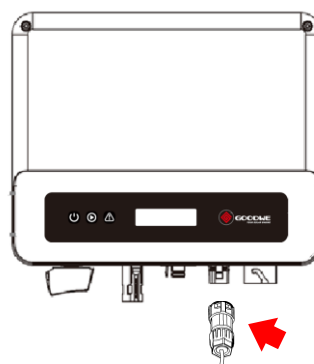

5. Zorg ervoor dat de communicatie-module goed is aangesloten (indien van toepassing)

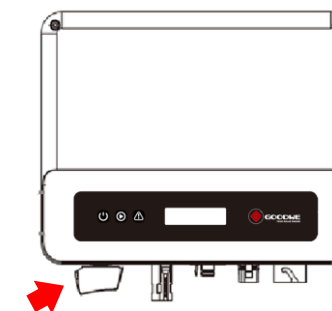

6. Schakel de DC- schakelaar van de omvormer in

# Locatie omvormer

Vermijd locaties met directe blootstelling aan:

- Zonlicht
- Regen
- Sneeuw

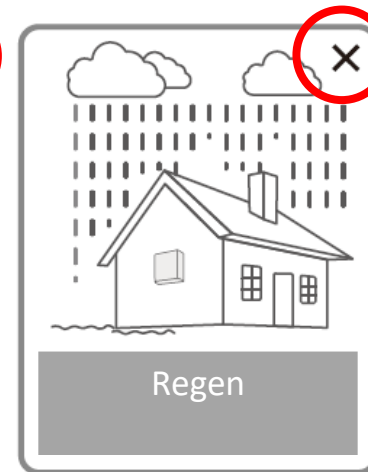

# Montage omvormer

- Houd rekening met de maximale hellingshoek– verschillend voor elke omvormer

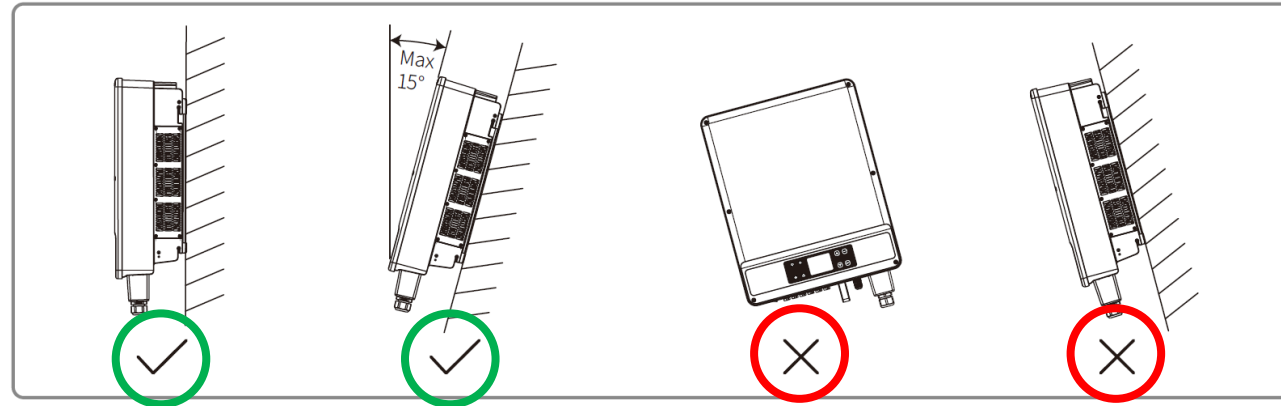



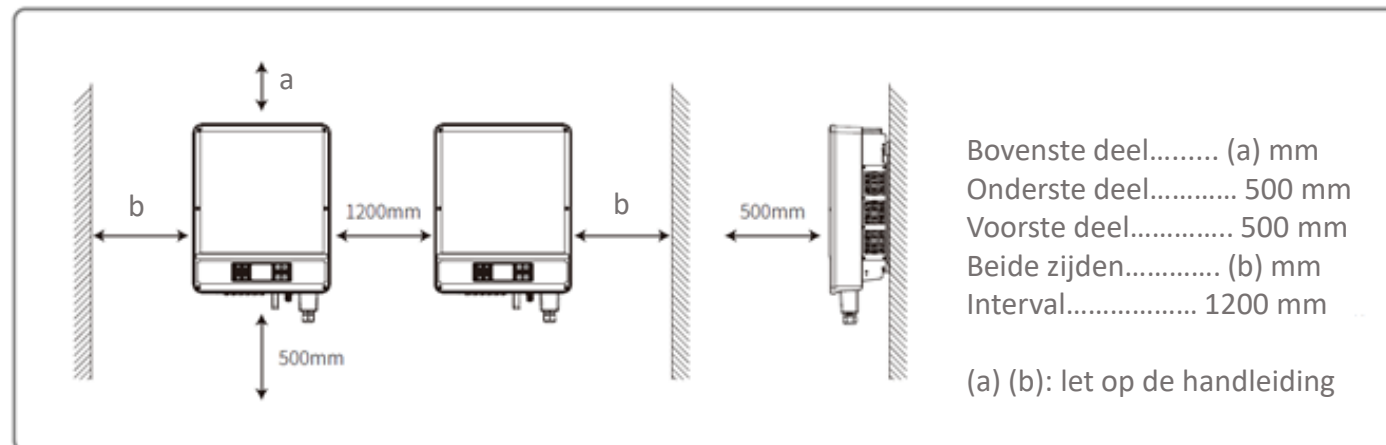

- Minimale vrije afstanden in acht nemen– verschillend voor elke omvormerserie



# Inbedrijfstelling – Grid setup Energieopslag



# Hybride Omvormers

	EM Series	ES Series	EH Series	ET Series
				
<b>Nominale AC uitgang</b>	3 – 5 kW	3.6 – 5 kW	3.6 – 6 kW	5 – 10 kW
<b>Netaansluiting</b>	1 fase	1 fase	1 fase	3 fase
<b>Lithium Accu</b>	LV	LV	HV	HV
<b>MPPTs</b>	1 - 2	2	2	2
<b>Max. Ontlaad / Laad Vermogen</b>	2.3 kW	3.6 – 5 kW	3.6 – 6 kW	5 – 10 kW
<b>Max. Backup Belasting</b>	2.3 kW	3.6 – 5 kW	3.6 – 6 kW	5 – 10 kW

## Standard Kenmerken



- Wi-Fi Communicatie
- CAN Accu Communicatie
- Inbedrijf stellen via PV Master App

- Geïntegreerde AC/DC SPD Type III
- Smart Meter voor vermogensbeheer
- DC schakelaar

## Optioneel:

- LAN Communicatie

# Retrofit Omvormer (AC-zijde)

	BH Series	BT Series
		
Nominale AC uitgang	3 – 6 kW	5 – 10 kW
Netaansluiting	1 fase	3 fase
Lithium Battery	HV	HV
Max. ontlad / laadvermogen	3 – 6 kW	5 – 10 kW
Max. backup belasting	3 – 6 kW	5 – 10 kW

## Standard Kenmerken

- Wi-Fi Communicatie
- CAN Battery Communicatie
- Inbedrijf stellen via PV Master App

- Geïntegreerde AC/DC SPD Type III
- Smart Meter voor vermogensbeheer

## Optioneel:

- LAN Communicatie

# Operation Logic

PV Supply priority :

**Loads → Battery → Export**

Solar power of the system will support loads first then charge battery, and the exceed power will be able to export to grid which could be limited.

- There is no priority supply to back-up power and on-grid power.
- The logic is based on the proper installation and normal communication of Smart Meter + CT

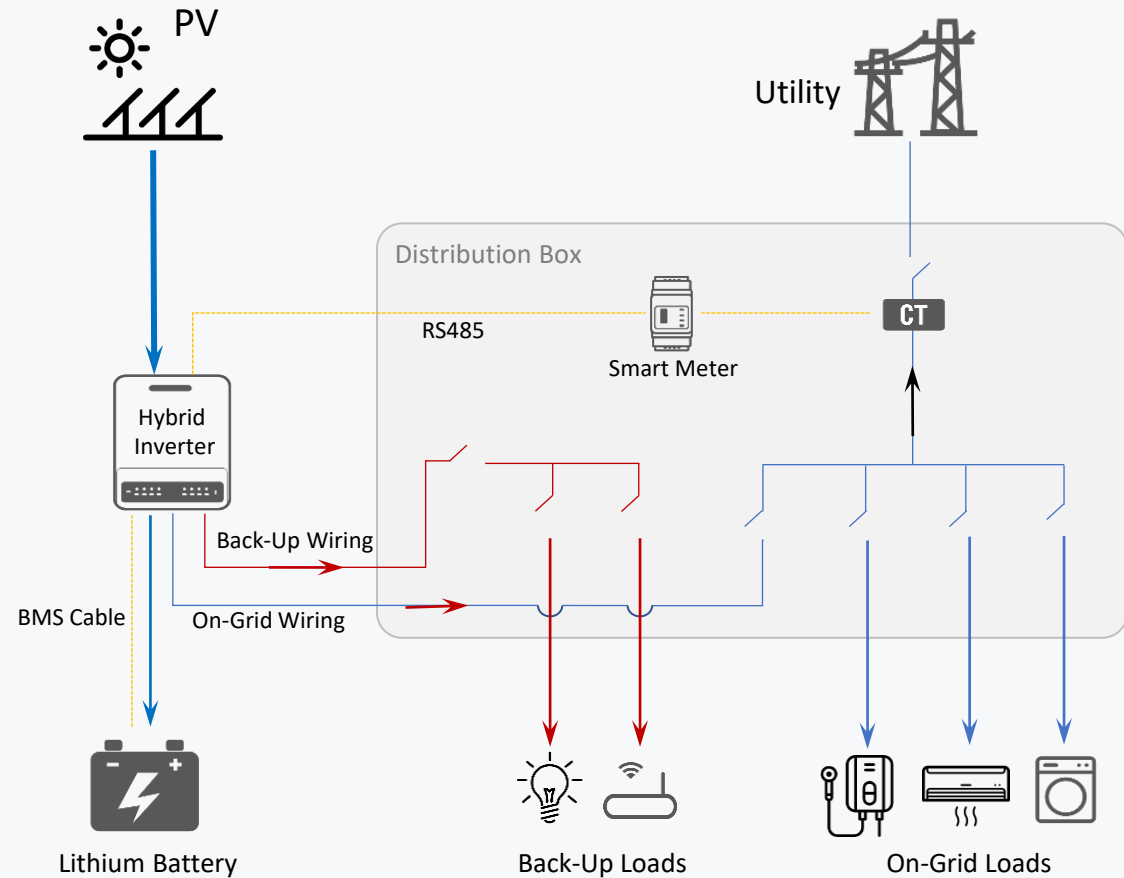

# Operation Logic – Off Grid

UPS Level Switch Time: **10 ms**

The system will switch from on-grid mode to off-grid mode if utility disconnected from the system uninterruptedly within 10ms, which can make sure the power supply on backup side for most of the house loads do not loss power for any second.

- There is limitation for backup load power, especially for inductive loads

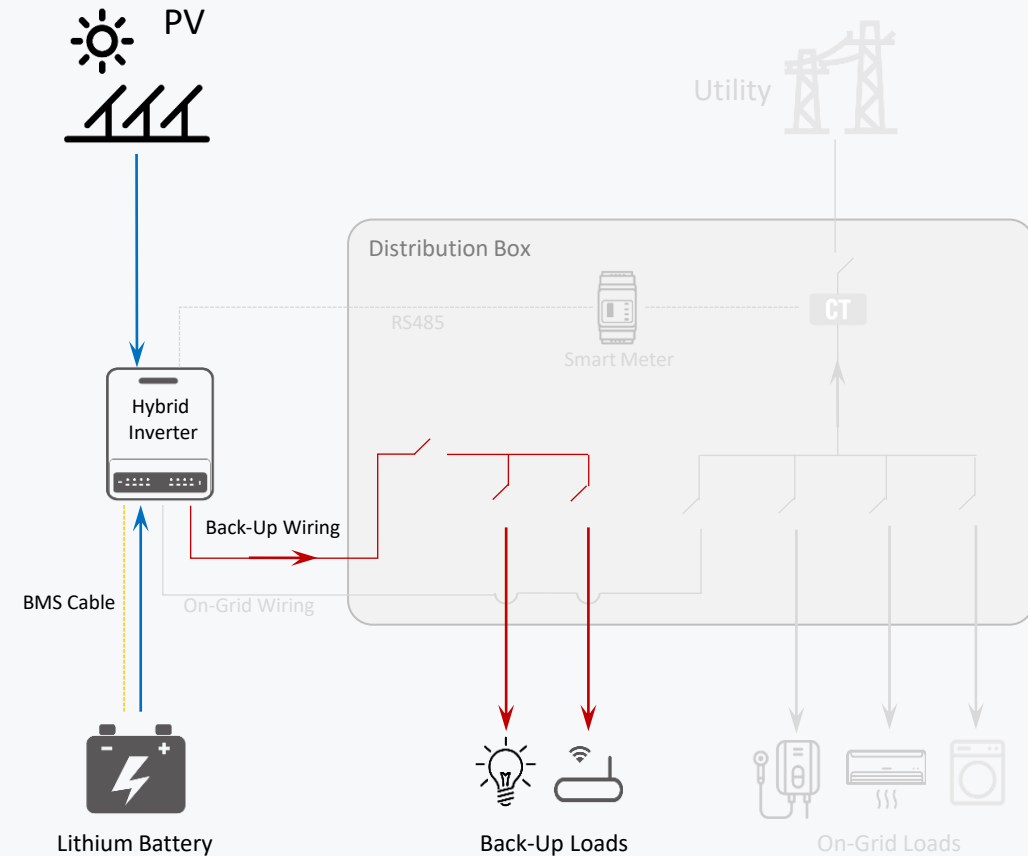

# AC Retrofit Solution

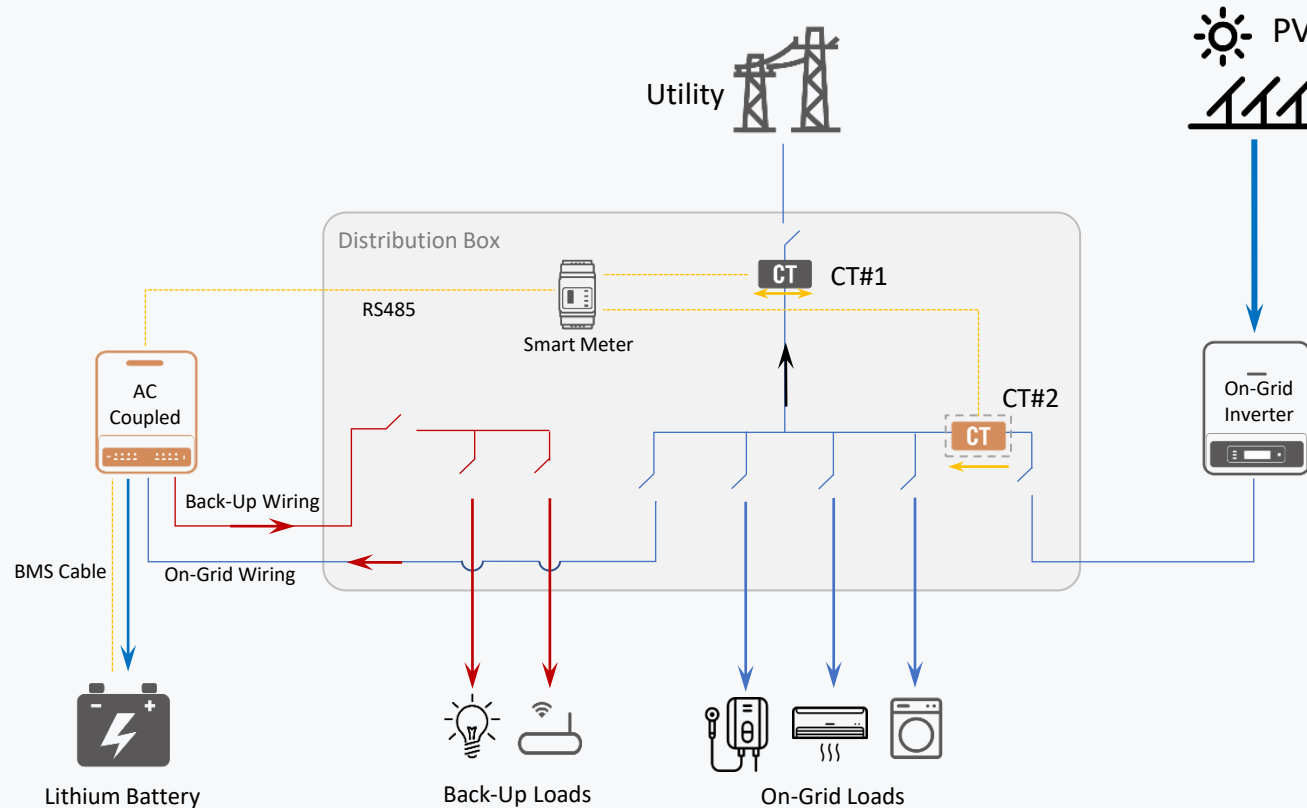

AC coupled inverter is used with grid solar inverters to update it to a complete energy storage system.

- There are 2 CTs to detect both solar production and grid interaction to make sure of the complete data monitoring
- The solution is for both single-phase and three-phase solar system of any brand.

# Integrated backup function

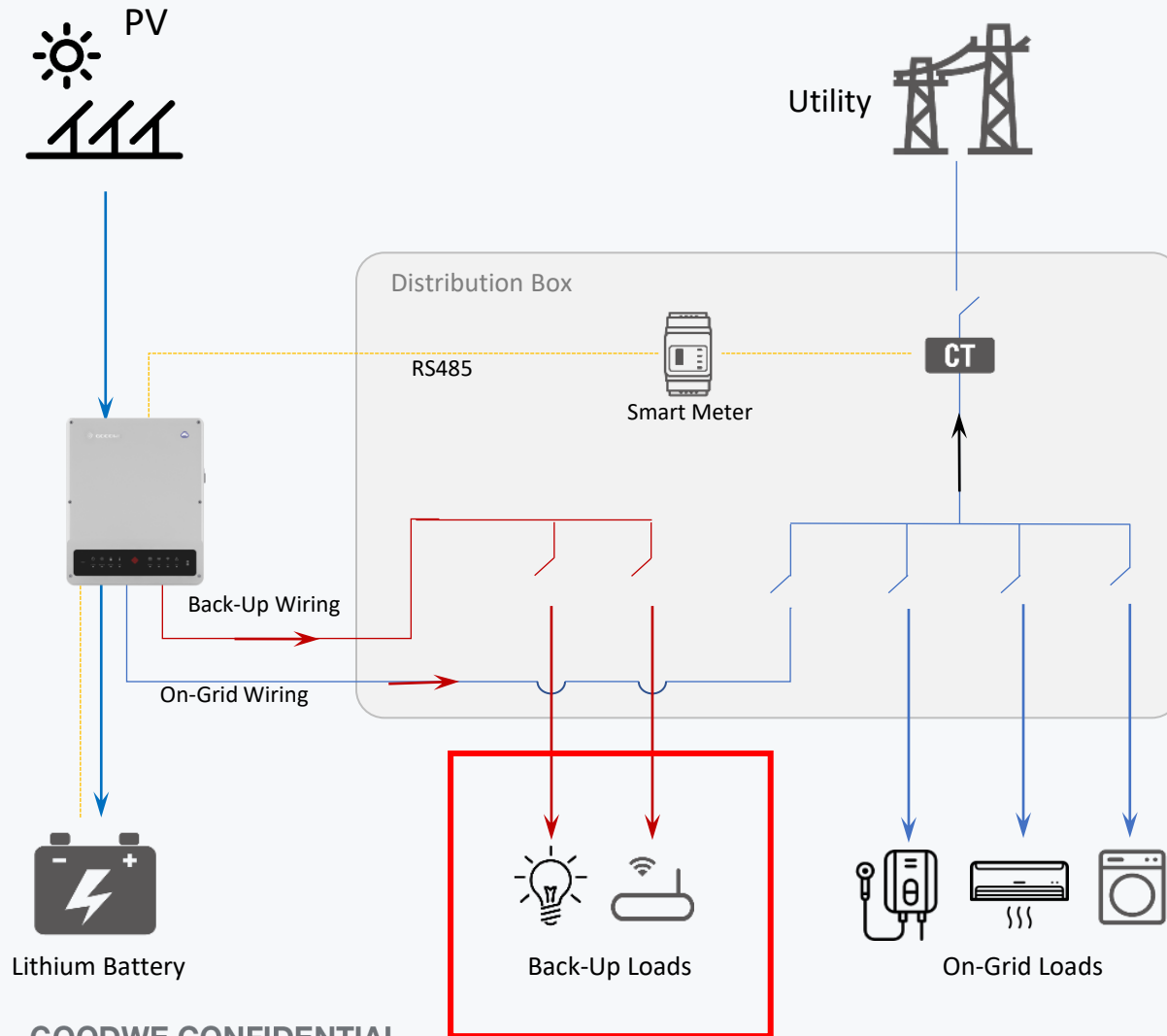

- Backup load power is limited
- Tipp: split loads in distribution box

	EM	ES / SBP	EH / BH
<b>Grid Connection</b>	1 phase	1 phase	1 phase
<b>Nominal AC output</b>	3 – 5 kW	3.6 – 5 kW	3.6 – 6 kW
<b>Max. Backup load</b>	2.3 kW	3.6 – 4.6 kW	3.6 – 6 kW

	ET / BT			
<b>Grid Connection</b>	3 phase			
<b>Nominal AC output</b>	5 kW	6.5 kW	8 kW	10 kW
<b>Max. Backup load per phase</b>	1.66 kW	2.16 kW	2.66 kW	3.33 kW

# ET Series – BYD

## Installatie & Inbedrijfstelling



# Volgorde van systeeminstelling



1. GoodWe onderdelen installeren
  - a) Omvormer
  - b) Slimme meter & CT's
2. BYD accu installeren
  - a) DC stroomkabels aansluiten op de omvormer
  - b) BMS accukabel aansluiten op de BMU
3. Inbedrijfstelling
  - a) BYD Be Connect App
  - b) GoodWe PV Master App
  - c) Internet & SEMS monitoring

## **Deze handleiding gaat ervan uit dat:**

- **ET omvormer is gemonteerd en aangesloten op de PV array**
- **BYD accumodules zijn gestapeld**



# Accu Compatibiliteit



# Accu Compatibiliteit

- BIJ TWIJFEL– kijk dan op onze website: <http://www.goodwe.com>

Gebruik de startpagina in elke taal

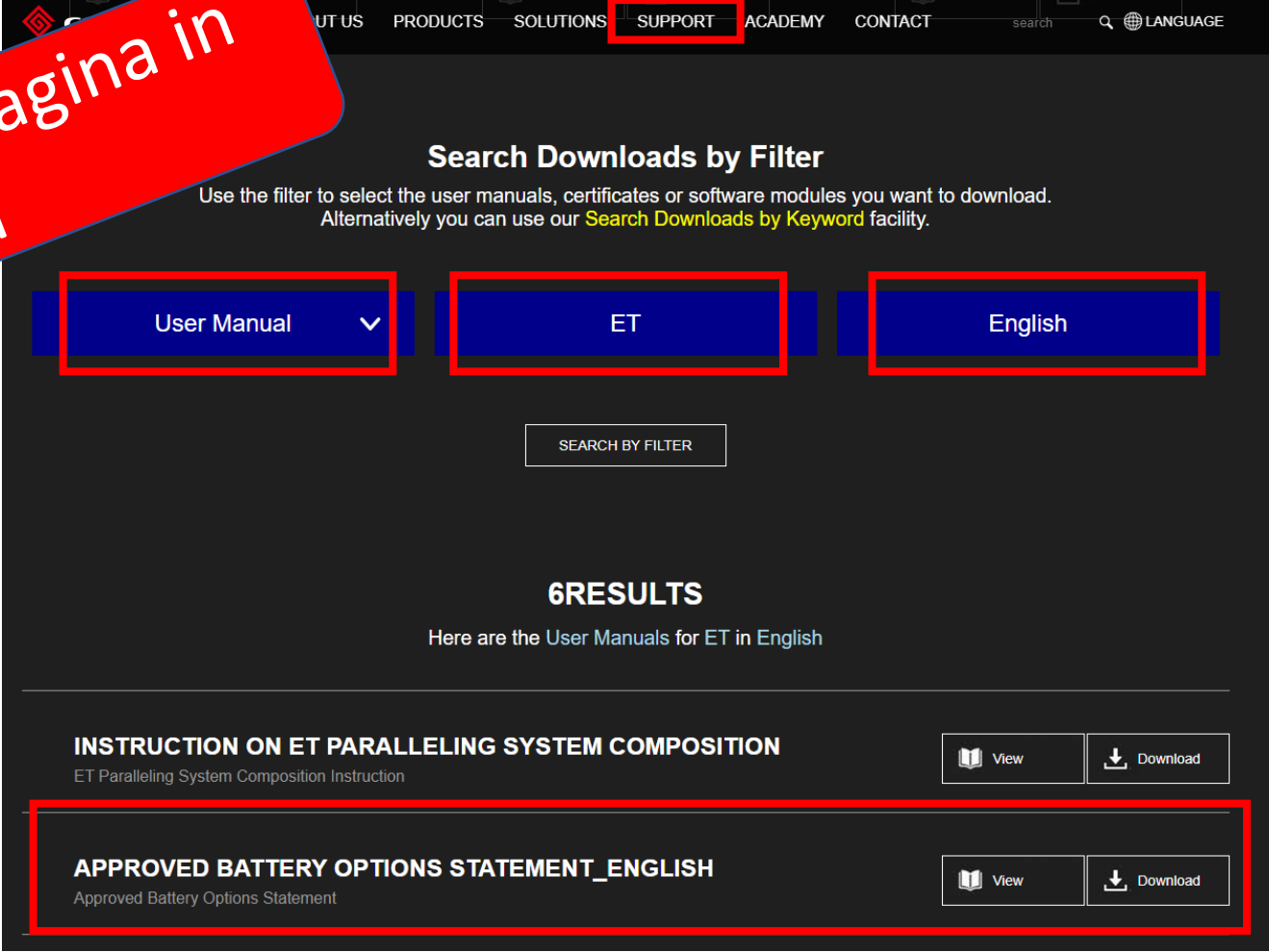

ABOUT US PRODUCTS SOLUTIONS **SUPPORT** ACADEMY CONTACT search LANGUAGE

### Search Downloads by Filter

Use the filter to select the user manuals, certificates or software modules you want to download. Alternatively you can use our [Search Downloads by Keyword](#) facility.

User Manual  ET  English

SEARCH BY FILTER

### 6RESULTS

Here are the User Manuals for ET in English

<b>INSTRUCTION ON ET PARALLELING SYSTEM COMPOSITION</b> ET Paralleling System Composition Instruction	<a href="#">View</a>	<a href="#">Download</a>
<b>APPROVED BATTERY OPTIONS STATEMENT_ENGLISH</b> Approved Battery Options Statement	<a href="#">View</a>	<a href="#">Download</a>

# Accu Compatibiliteit



- Goedgekeurde accuverklaring
- NIET INSTALLEREN ALS DEZE NIET OP DE LIJST STAAT

Battery Brand	Battery Series	Battery Model	Inverter Series								
			ES	EM	BP	SBP	ET	BT	EH	BH	
BYD	Battery-Box Premium HVM* <sup>1</sup>	HVM 8.3								●	●
		HVM 11.0					●	●	●	●	●
		HVM 13.8					●	●	●	●	●
		HVM 16.6					●	●	●	●	●
		HVM 19.3					●	●	●	●	●
		HVM 22.1					●	●			
	Battery-Box Premium HVS* <sup>1</sup>	HVS 5.1					●	●	●	●	●
		HVS 7.7					●	●	●	●	●
		HVS 10.2					●	●			
		HVS 12.8					●	●			

# Accu Compatibiliteit

- BYD HVS – mini-BEAST MODE
- Maximaal drie torens per omvormer– tot 38.4 kWh



HVS 5.1

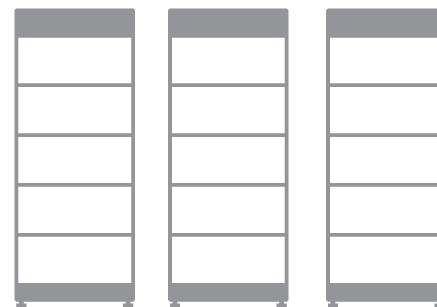

3 x HVS 12.8

# Accu Compatibiliteit

- BYD HVM – BEAST MODE
- Maximaal drie torens per omvormer– tot 66.2 kWh

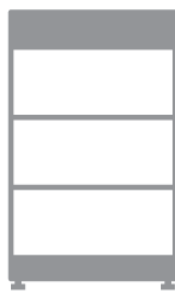

HVM 8.3

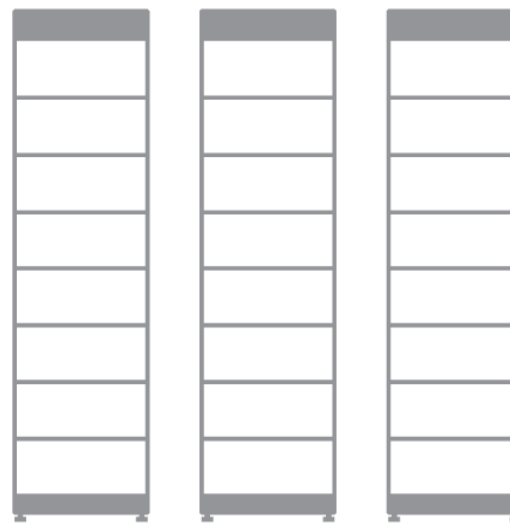

3 x HVM 22.1

# GoodWe Smart Meter



# Stelsiem verbindingen – Slimme Meter / CT

- Communicatiekabel is vooraf bedraad
- Kabel van omvormer wordt aangesloten op de RJ45 poort op de slimme meter

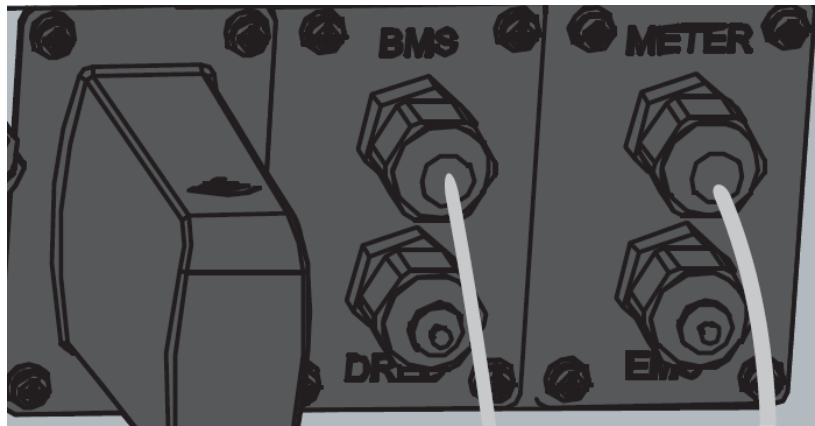

# Stelsel aansluitingen – Slimme Meter / CT

- DE JUISTE PLAATSING IS **BELANGRIJK!**
- CT's – meet de elektriciteitsstroom VAN en NAAR het grid
- CT's – meet IMPORT / EXPORT

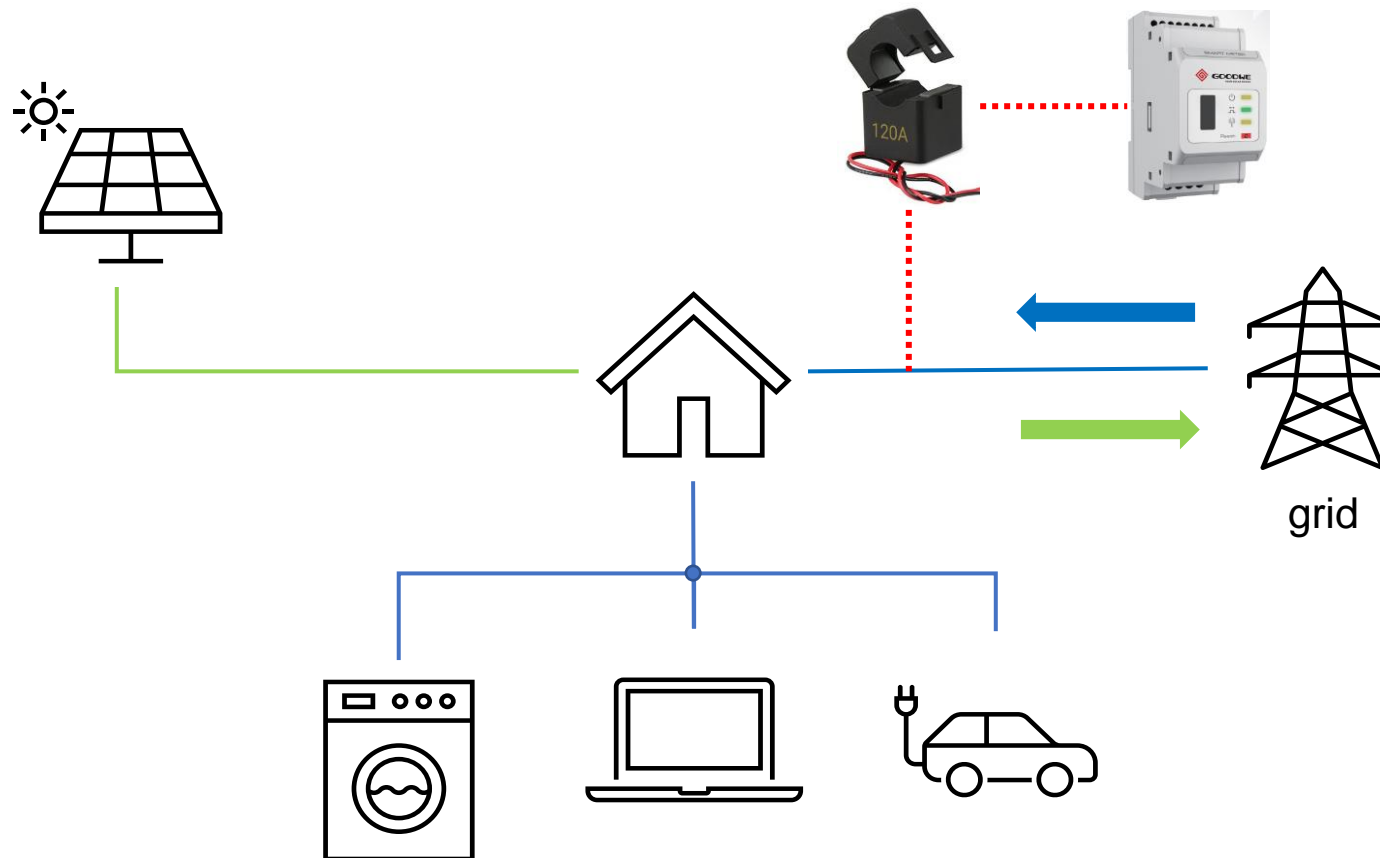



# Stelsel aansluitingen – Slimme Meter / CT

- CT's moeten worden geïnstalleerd na de HOOFTmeter en **ALTIJD VOOR DE VERBRUIKERS EN OMVORMER!**

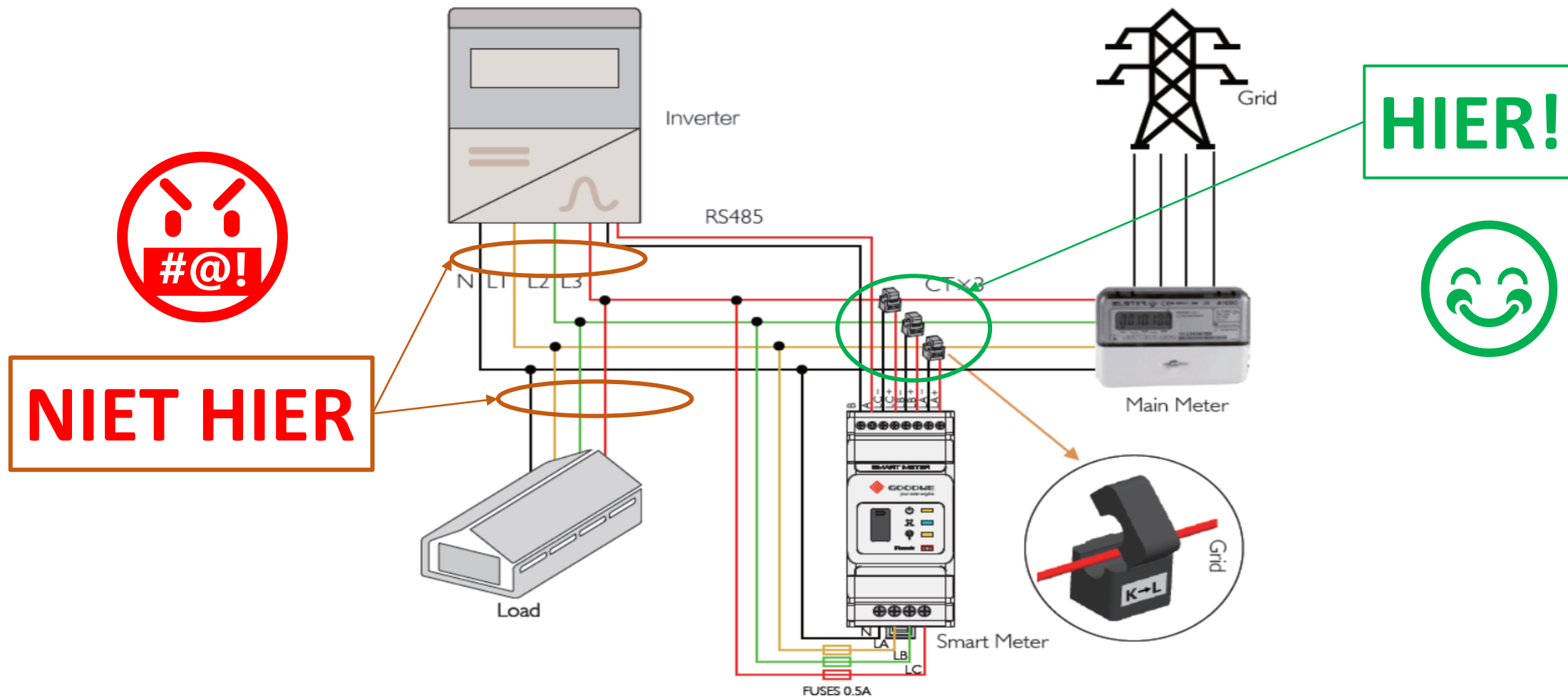

# Systeem verbindingen – Slimme Meter / CT

- Elke CT is gelabeld
- L1 – CT A, L2 – CT B, L3 – CT C

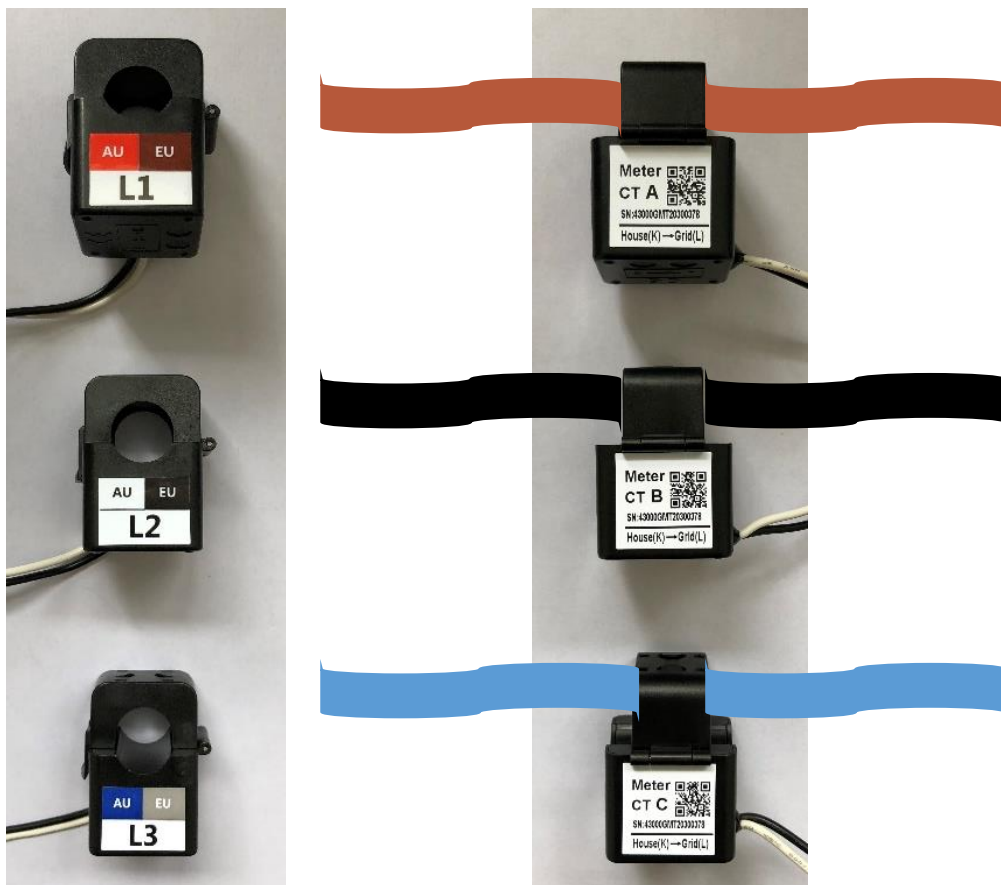

Pijlen wijzen naar het grid

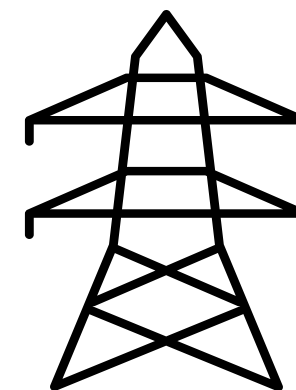

grid

# Stelsel aansluitingen – Slimme Meter / CT

- Pijl moet naar het Grid wijzen

- Pijl en L moeten naar het GRID wijzen
- L betekent niet „L“oads

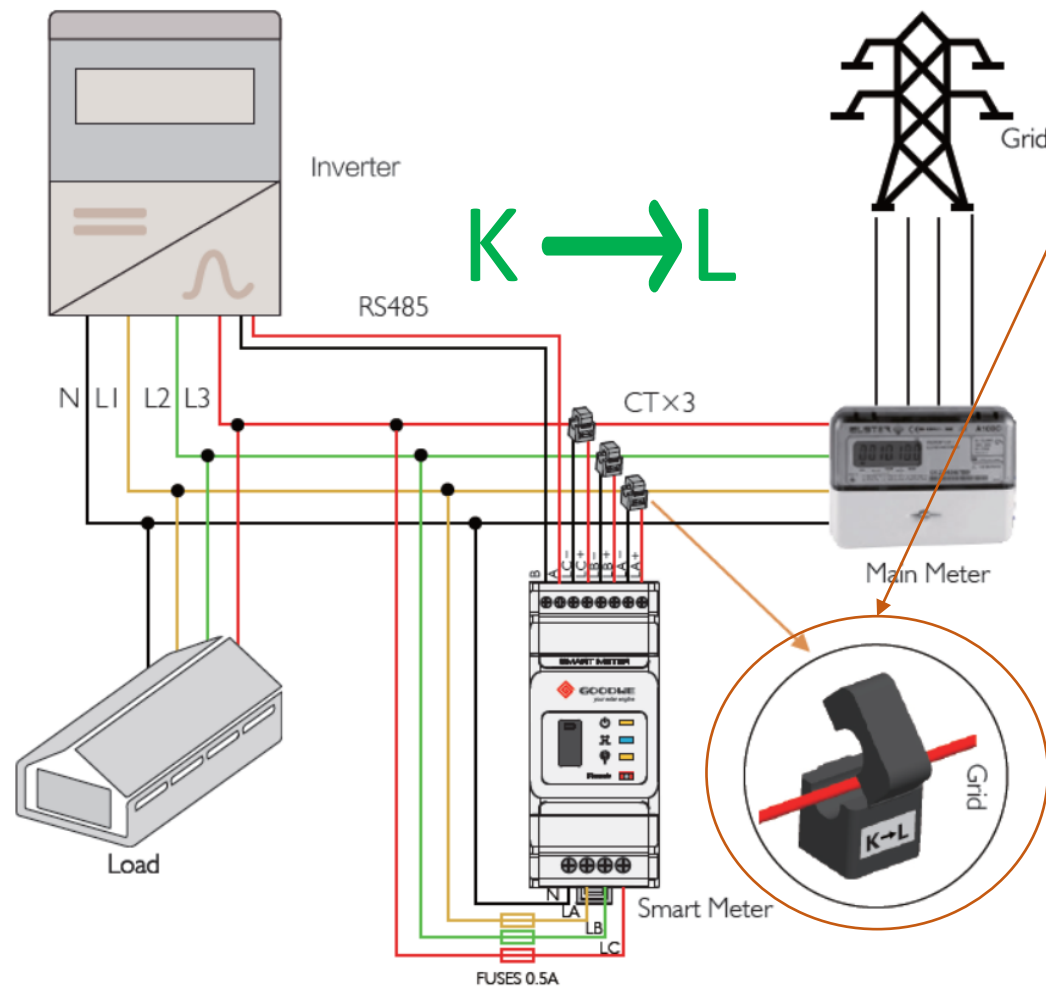

L



**L WIJZEND NAAR DE  
OMVORMER of LOADS  
VERKEERDE RICHTING!**

# Stelsel verbindingen – Slimme Meter / CT

- CT A – Fase 1 – Pin 7/8
- CT B – Fase 2 – Pin 5/6
- CT C – Fase 3 – Pin 3/4

**Fasen worden omgekeerd van links naar rechts  
geordend  
C – B – A**

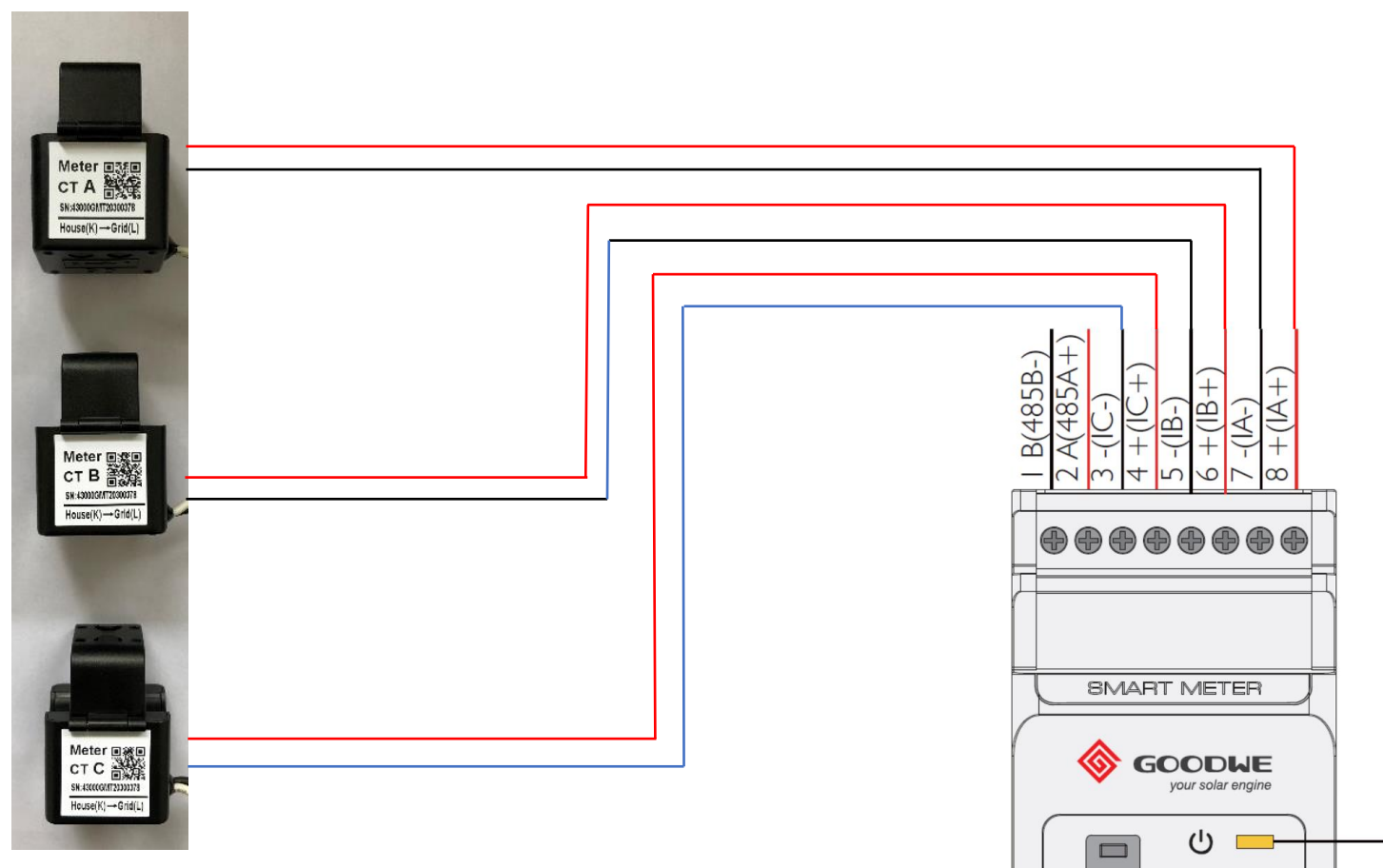

# Stelsel aansluitingen – Slimme Meter / CT

- LA – Fase 1 – Pin 10 ~ **CT A**
- LB – Fase 2 – Pin 11 ~ **CT B**
- LC – Fase 3 – Pin 12 ~ **CT C**

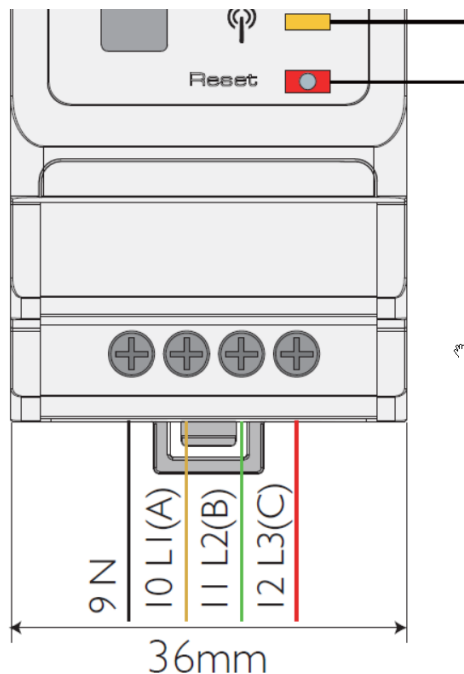

**Fasen worden van links naar rechts geordend  
A – B – C**

Controleer de  
spannings  
detectie  
kabels

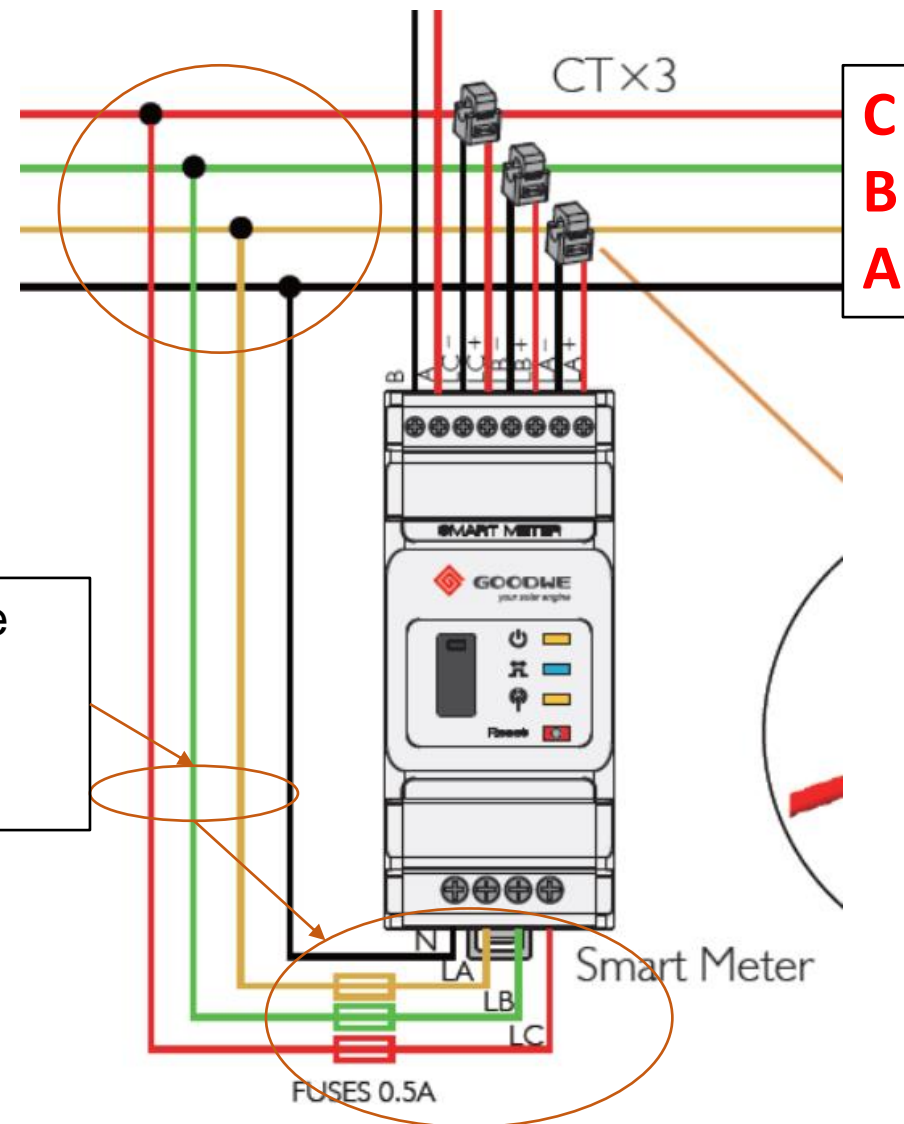

# Stelsiem verbindingen – Slimme Meter / CT

- Smart meter isolatie punt

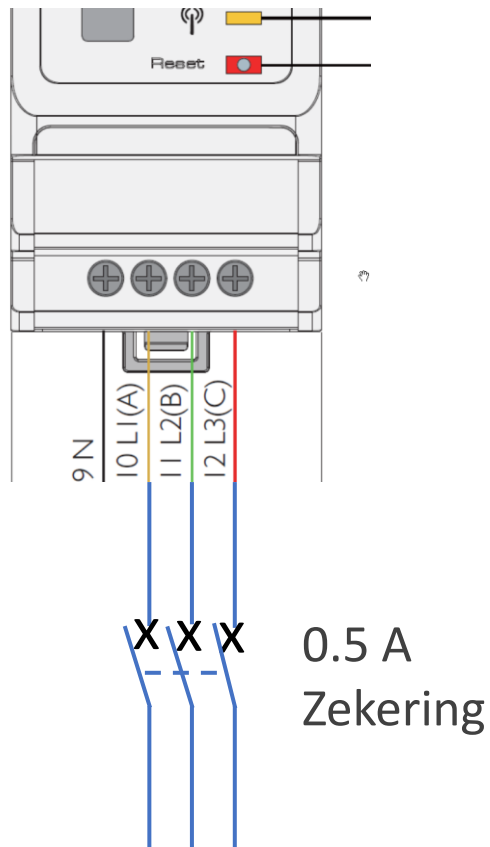

OF

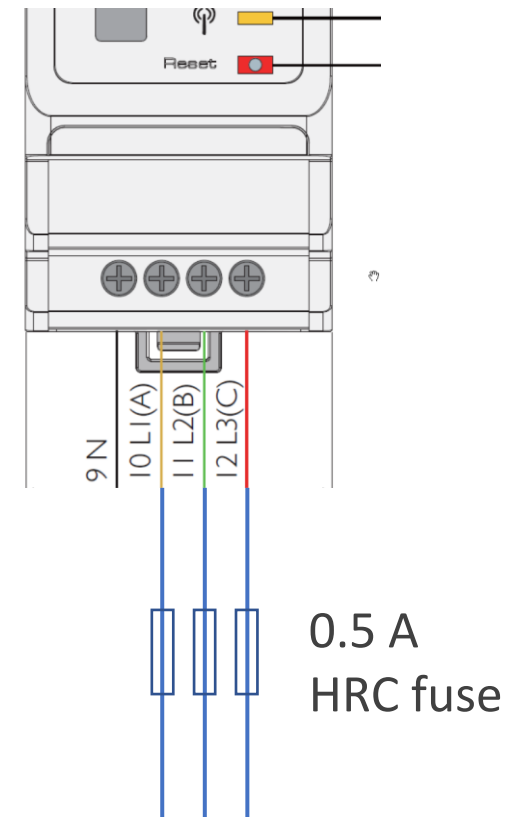

# Systeem verbindingen – Slimme Meter / CT

- BOVEN - **ORANJE LED** – Power – moet AAN zijn
- MIDDEN - **BLAUWE LED** – Energiestroom:
  - Blijft aan – consumeren
  - Knipperen - exporteren
- ONDER – **ORANJE LED** – Communicatie
  - Knipperen – gegevens verzenden
  - Resetten – knippert 5 keer



Vergelijk ENERGIESTROOM met de werkelijke lading ON-SITE

- Schakel enkele belastingen in – Kookplaat/ waterkoker



# BYD Accu





# Eisen

- ET series hybride
  - FW ARM Versie 11 of hoger
- BYD HVM/HVS Accu
- Android of iPhone (mobile apparaat)
- GoodWe PV Master App

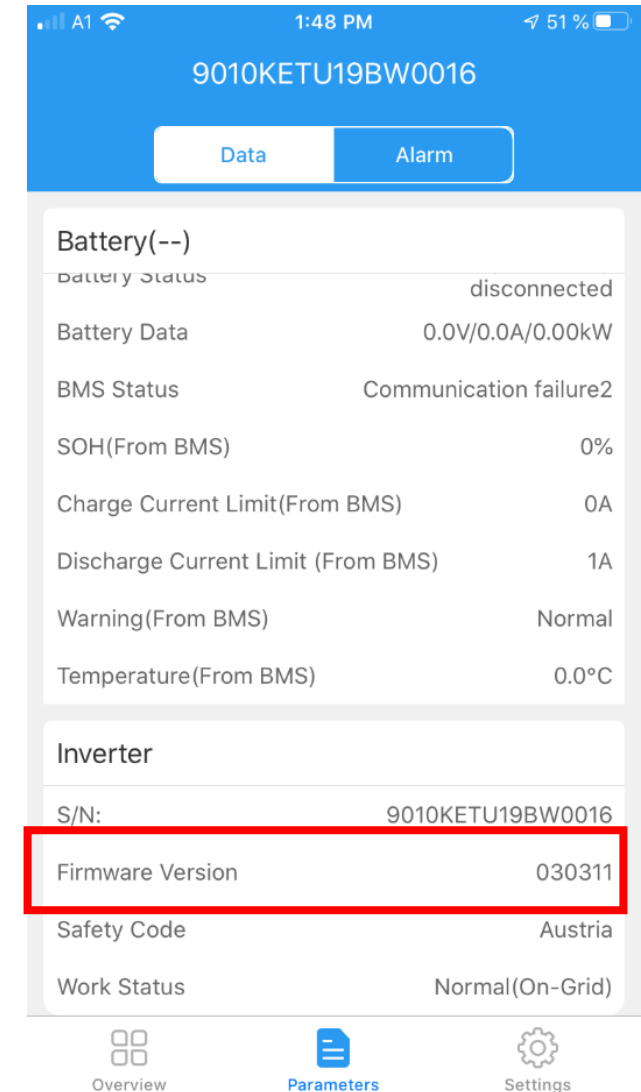

The screenshot shows the GoodWe PV Master App interface. At the top, there is a blue header with the device ID '9010KETU19BW0016' and two tabs: 'Data' and 'Alarm'. Below the header, there are two main sections: 'Battery(--)' and 'Inverter'. The 'Battery(--)' section displays various status and data points. The 'Inverter' section displays S/N, Firmware Version, Safety Code, and Work Status. The 'Firmware Version' field is highlighted with a red border.

Battery(--)	
Battery Status	disconnected
Battery Data	0.0V/0.0A/0.00kW
BMS Status	Communication failure2
SOH(From BMS)	0%
Charge Current Limit(From BMS)	0A
Discharge Current Limit (From BMS)	1A
Warning(From BMS)	Normal
Temperature(From BMS)	0.0°C

Inverter	
S/N:	9010KETU19BW0016
Firmware Version	030311
Safety Code	Austria
Work Status	Normal(On-Grid)

Navigation icons at the bottom: Overview, Parameters, Settings.

# Systeem Verbindingen

- Schakel accu DC isolator uit



- Verwijder BMU afdekplaat om toegang te krijgen tot de terminals

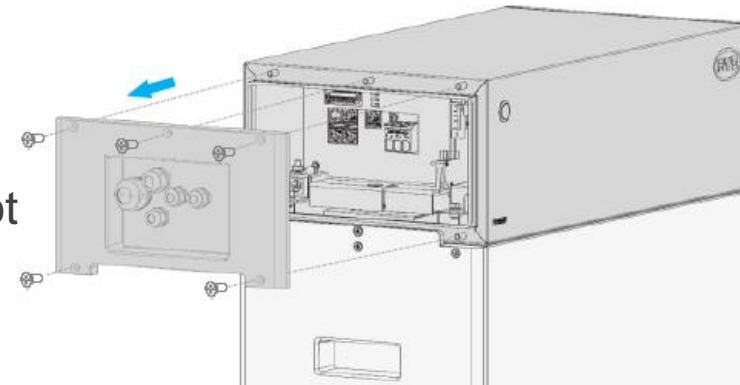

# Systeem Verbindingen - Accu

- Sluit een uiteinde van de DC voedingskabels aan op de Sunclix connectoren – raadpleeg de ET installatie handleiding
  - Kabelgrootte: 4-6 mm<sup>2</sup>
- Sluit DC stroomkabels aan op “BATT”- ingang op de omvormer
- Steek het andere uiteinde van de DC kabels in de BYD accu terminal

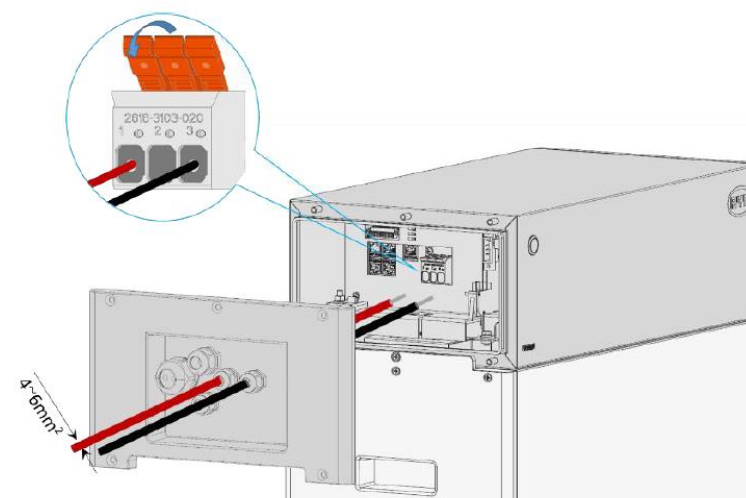
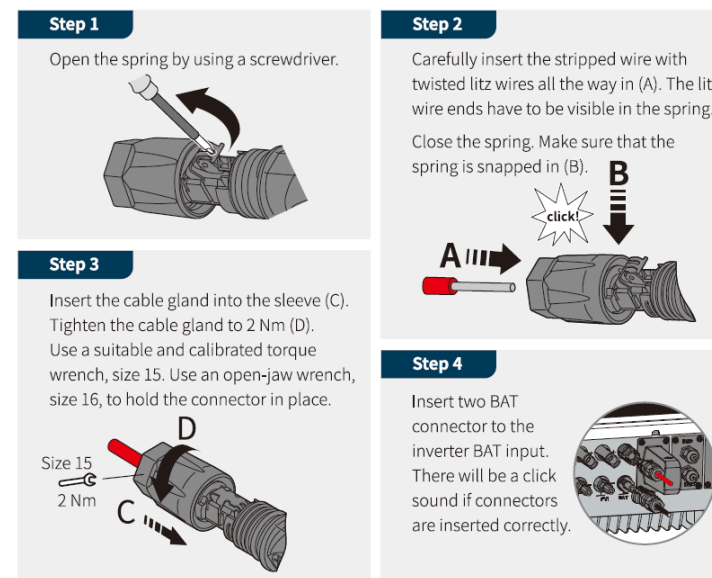

# Stelsel Verbindings- BMS Kabel

- Voorbedrade BMU kabel wordt meegeleverd
- Knip de RJ45 connector van de voorbedrade BMS kabel af

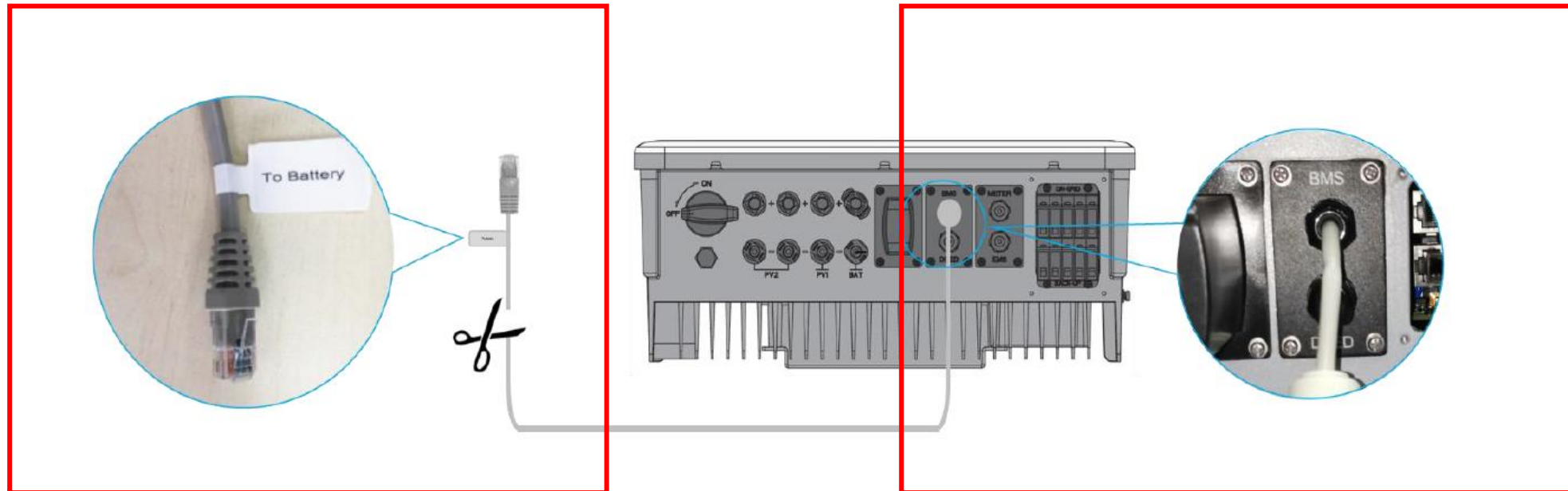

# Stelsiem Verbindingen– BMS Kabel

- Zoek de Blauwe en Blauw/Witte kabel waarvan het einde is GESNEDEN
- Sluit de Blauwe en Blauw/Witte kabel aan
  - Blauwe – Terminal 1 (Can\_H)
  - Blauw/Witte – Terminal 2 (Can\_L)

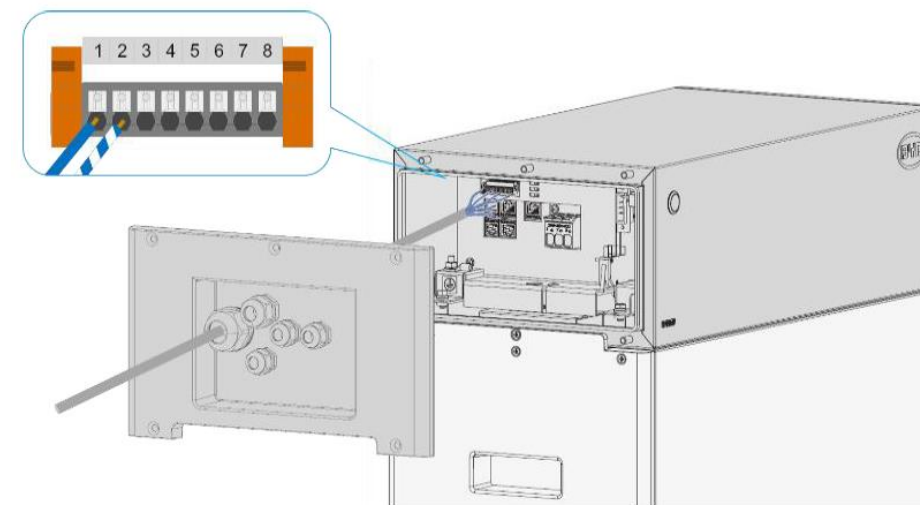
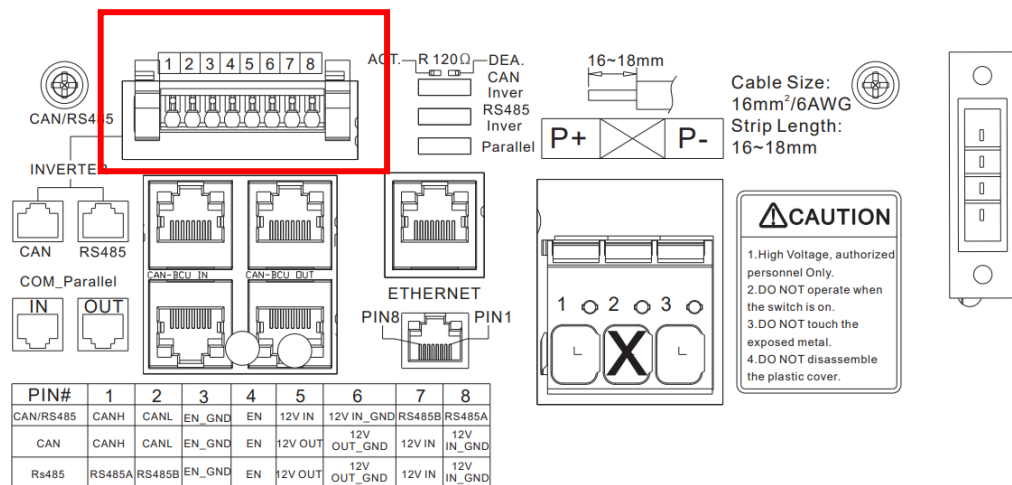
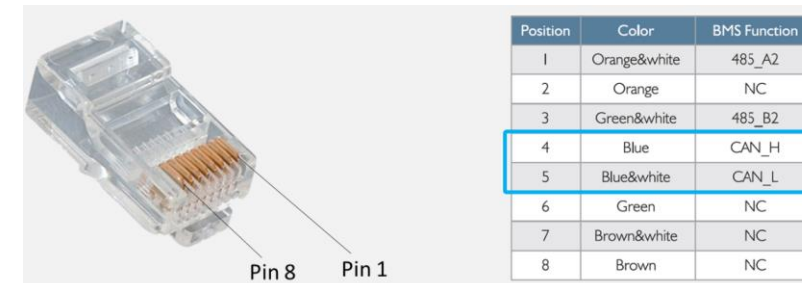

# Stelsel Verbindings- BMS Kabel

- INSTELLINGEN VOOR DIP SCHAKELAAR – EEN ACCU
  - LINKER POSITIE

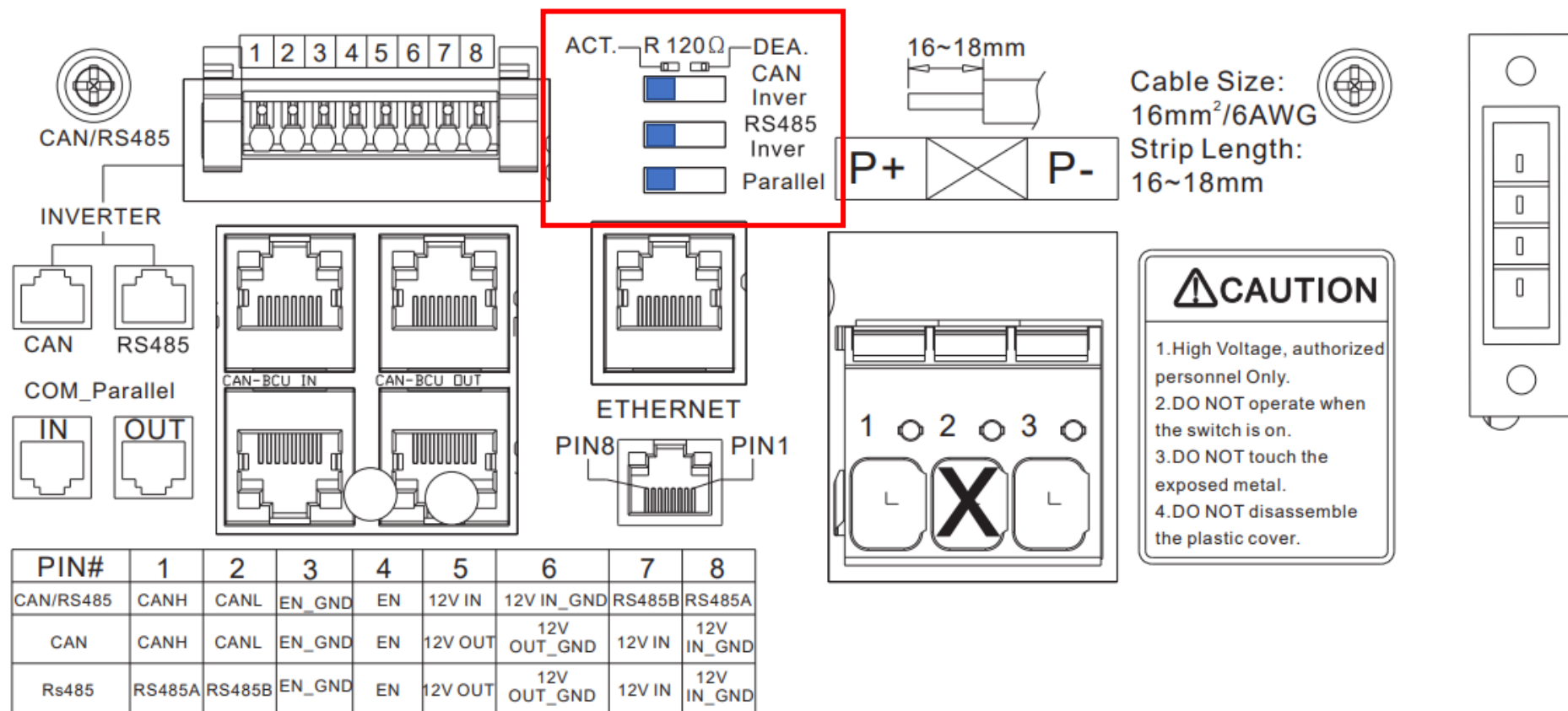

# Stelsel Verbindings- BMS Kabel

- INSTELLINGEN VOOR DIP SCHAKELAAR- TWEE ACCU'S

HVS/HVM



Master

HVS/HVM



Slave 1

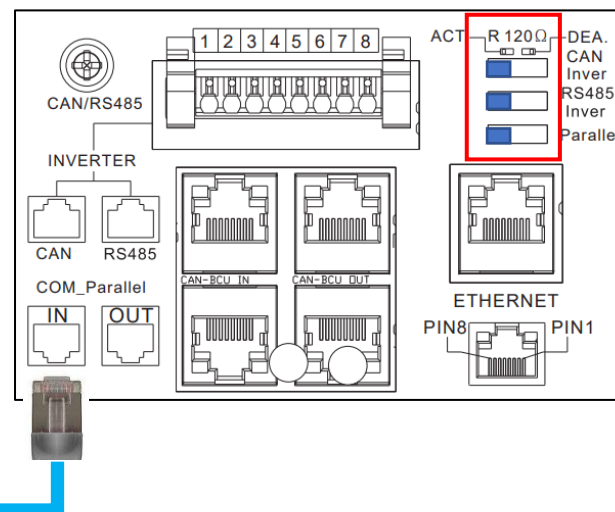
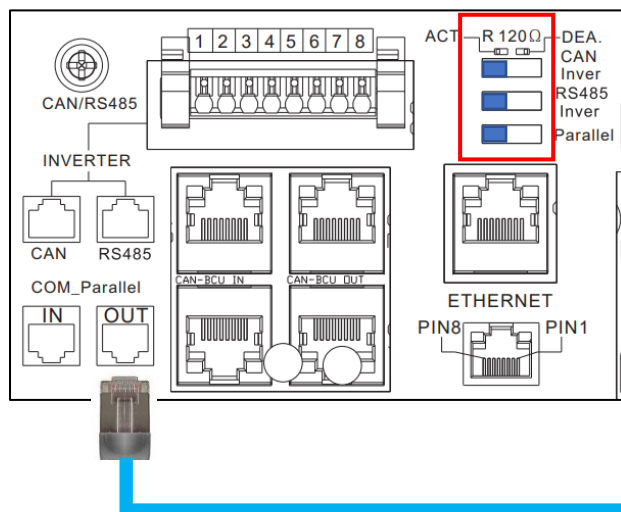

# Stelsel Verbindings- BMS Kabel

- INSTELLINGEN VOOR DIP SCHAKELAAR- DRIE ACCU'S

HVS/HVM



Master

HVS/HVM



Slave 1

HVS/HVM

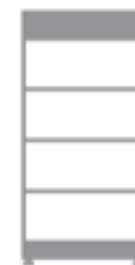

Slave 2

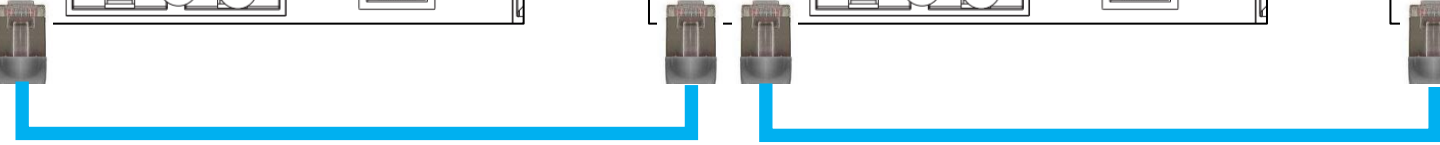
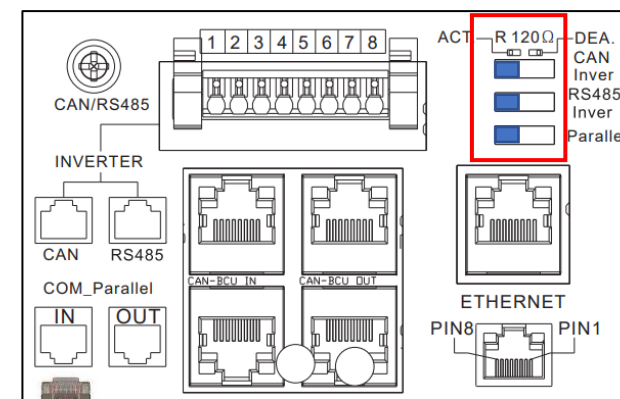
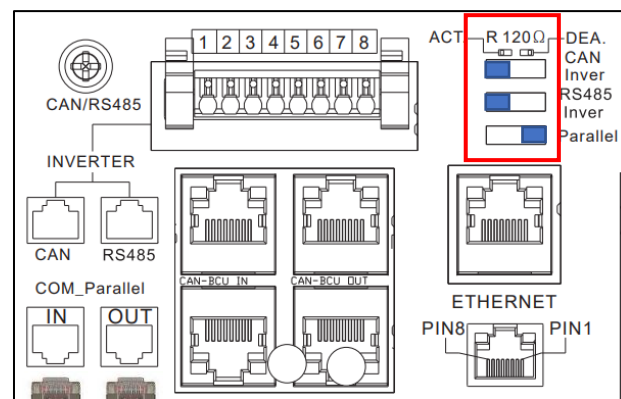
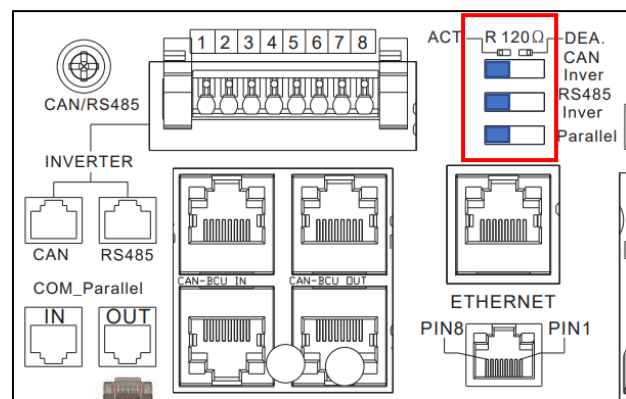



# BYD Inbedrijfstelling

- Schakel accu DC isolator in
- Gebruik BYD “Be Connect” App om:
  - Selecteer download battery FW
  - Selecteer GOODWE HV
  - Selecteer HVM/HVS model
  - Voer het aantal modules in
  - Raadpleeg bij twijfel BYD handleiding

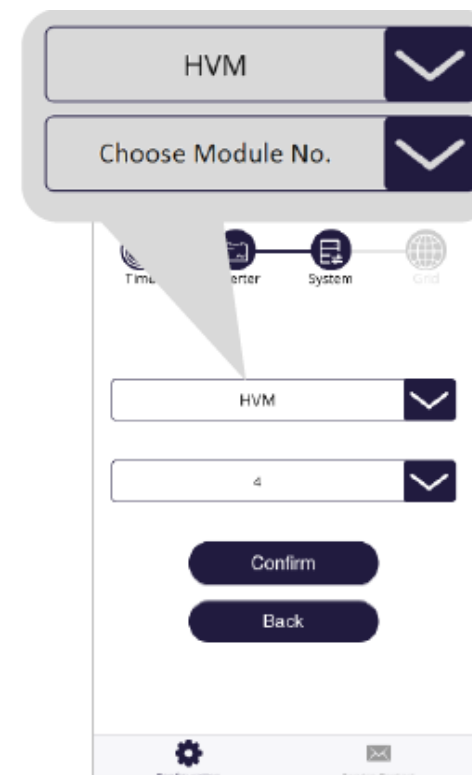
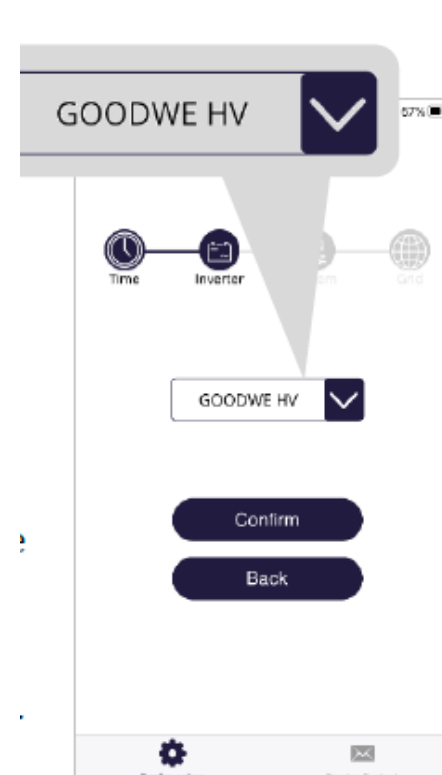

Na setup:

- Alle apparaten UITSCHAKELEN (omvormer + accu)
- Wacht 2 minuten
- Alle apparaten INSCHAKELEN

# GoodWe PV Master APP



# Omvormer Inbedrijfstelling

- Schakel PV- array en DC- isolator in
- Aanbevolen – schakel omvormer AC isolator UIT
- Maak verbinding met het WiFi toegangspunt van de omvormer “Solar-Wifixxxxxx”
- Wachtwoord: 12345678
- Gebruik PV Master App
  - Voer basisinstellingen in
  - Indien gevraagd-  
wachtwoord: goodwe2010



1. Voor Android telefoon:
  - Schakel “Vliegtuigmodus” in
  - Zet dan alleen “Wifi” aan
2. Zet de omvormer UIT AC schakelaar/stroomonderbreker

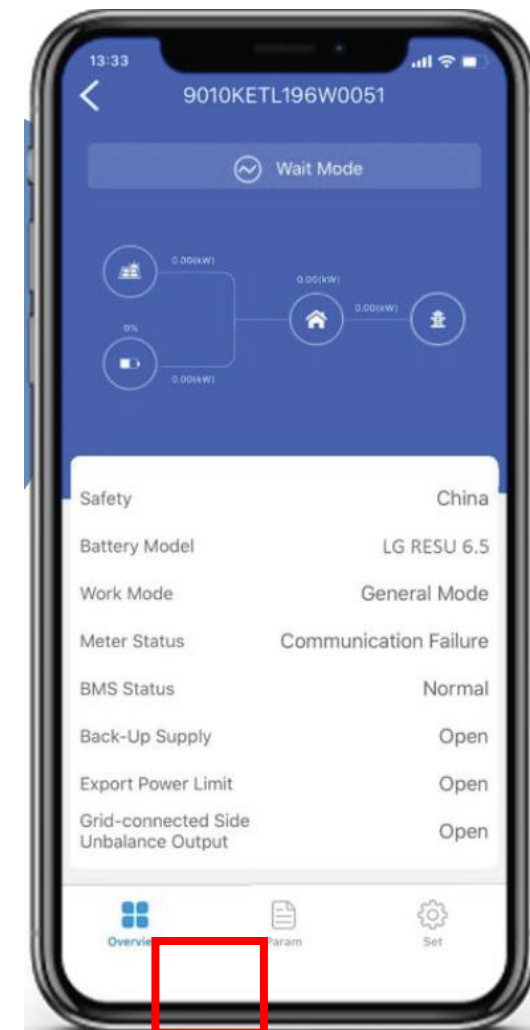

# Omvormer Inbedrijfstelling

- Selecteer instelling voor landveiligheid

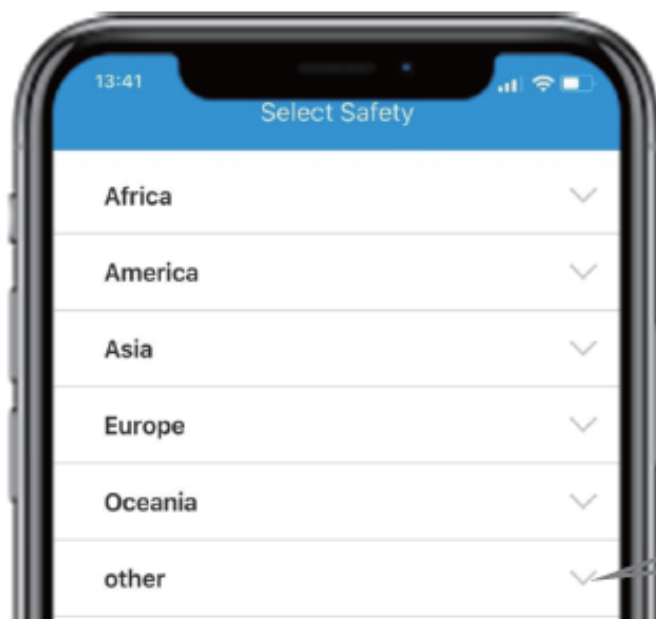

## Veiligheidscode selecteren

Selecteer de juiste code op basis van uw installatiegebied.  
Als het niet in de lijst staat, zoek er dan één in "other"

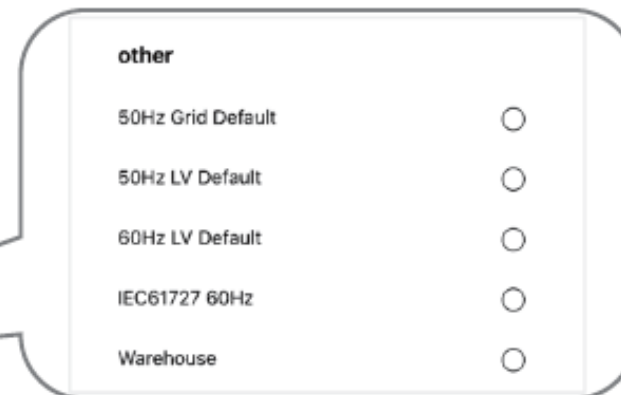

# Omvormer Inbedrijfstelling

- Selecteer werkmodus – Meestal “General Mode”

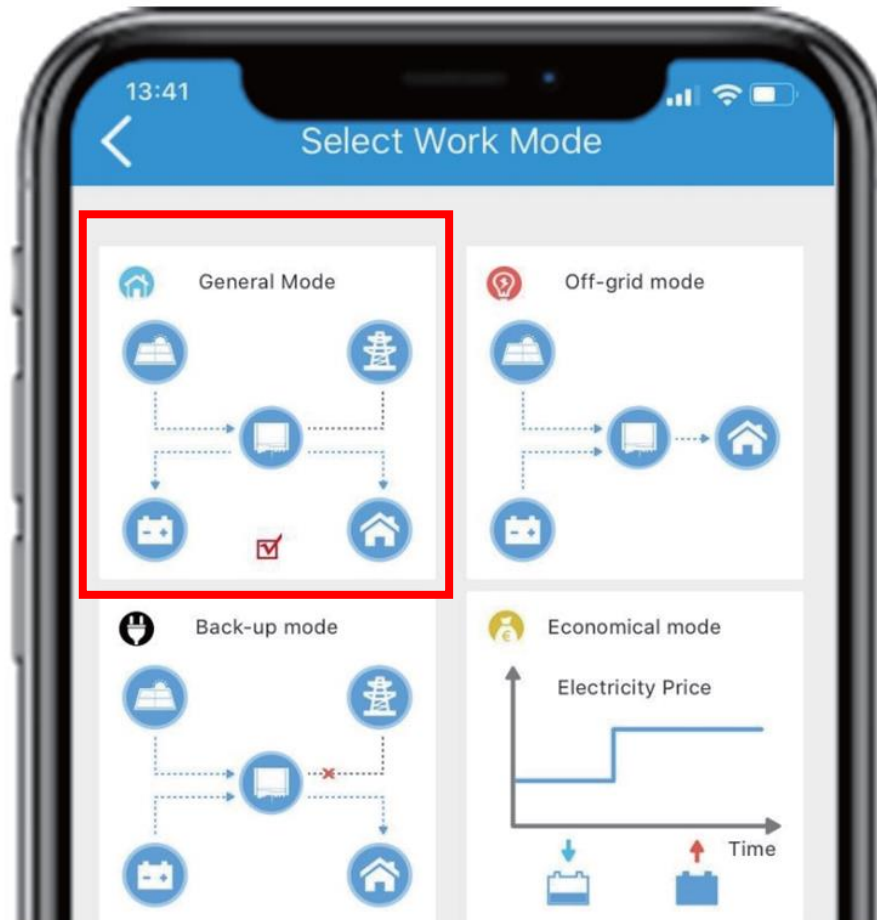

# Omvormer Inbedrijfstelling



- Selecteer “BYD-Box Premium HVS of HVM”

Currently selected battery  
Manufacturer:--  
Series:--  
Model:--

GoodWe

PYLON

BYD

BYD-Box H

BYD-Box Premium HVM

BYD-Box Premium HVS

DYNESS

If no available battery model is found, please open the mobile network and resart APP to acquire

Previous Next

# Omvormer Inbedrijfstelling

- CT Meter test – kan worden overgeslagen en in een later stadium worden gedaan
- Schakel AC- isolator in
- Wacht tot de omvormer is aangesloten op het net – voer CT meter test uit



1. Zet de omvormer AAN AC schakelaar/stroomonderbreker
2. GRID LED moet solide zijn VOORDAT u test uitvoert

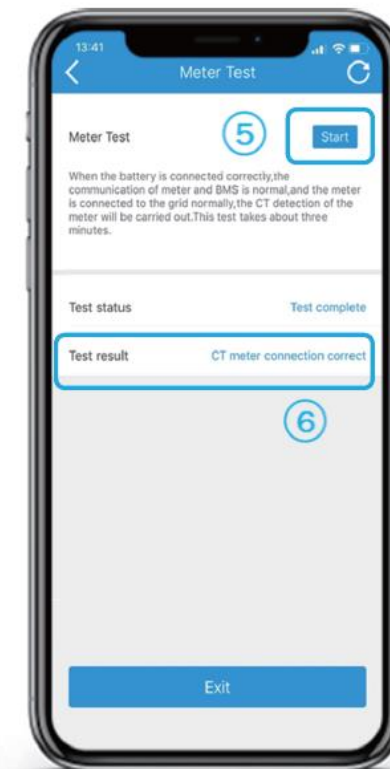
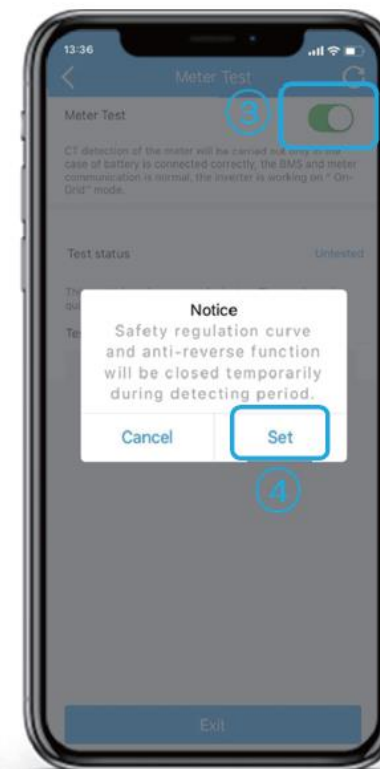
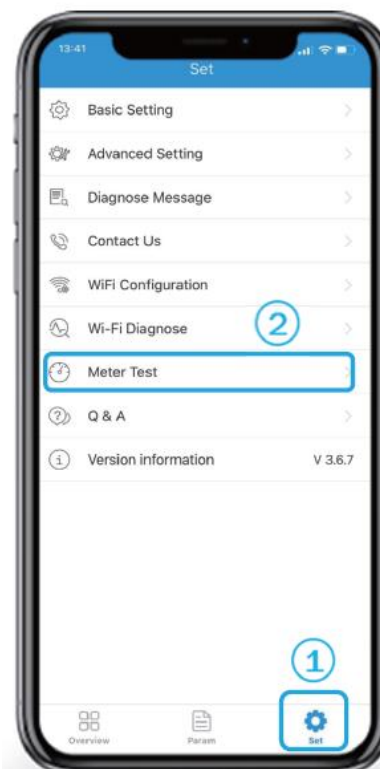
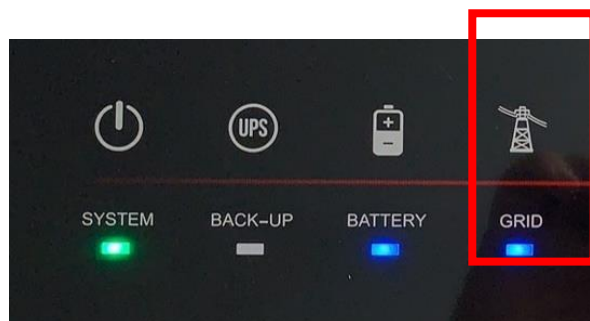

# Export Control

- Klik op “Advanced Setting”
- Inschakelen – “Export Power Limit”
- Voer de waarde van het exportvermogen in Watt (W) in
- Klik op “Set”

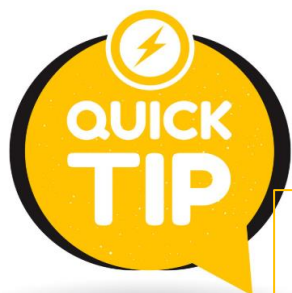

1. Voor Android telefoon:
  - Schakel “Vliegtuigmodus” in
  - Zet dan alleen “Wifi” aan

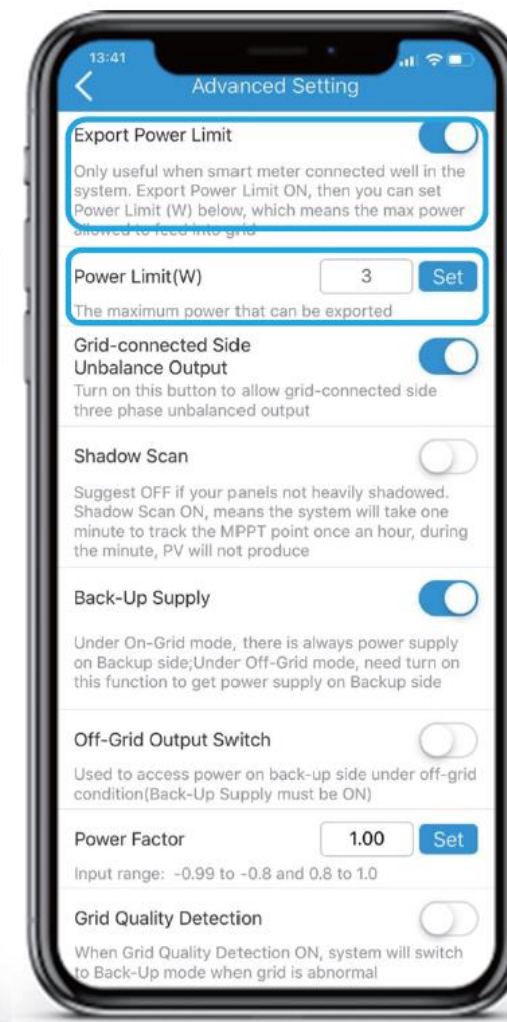
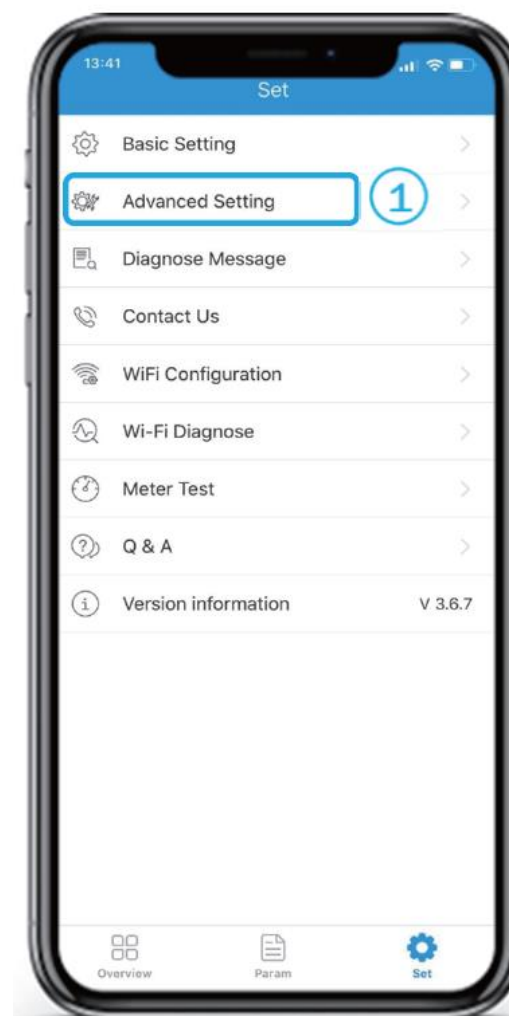



# Back-up Functie

- De back-up output op de omvormer moet zijn ingeschakeld
  - Schakel “Back-Up Supply” in
- Om de Back-up “UPS”-modus in te schakelen tijdens netstoring
  - Back-up belastingen geleverd door accu en PV
  - Schakel “Off-Grid Output Switch” in
- Klik op “Set”



1. Voor Android telefoon:
  - Schakel “Vliegtuigmodus” in
  - Zet dan alleen “Wifi” aan

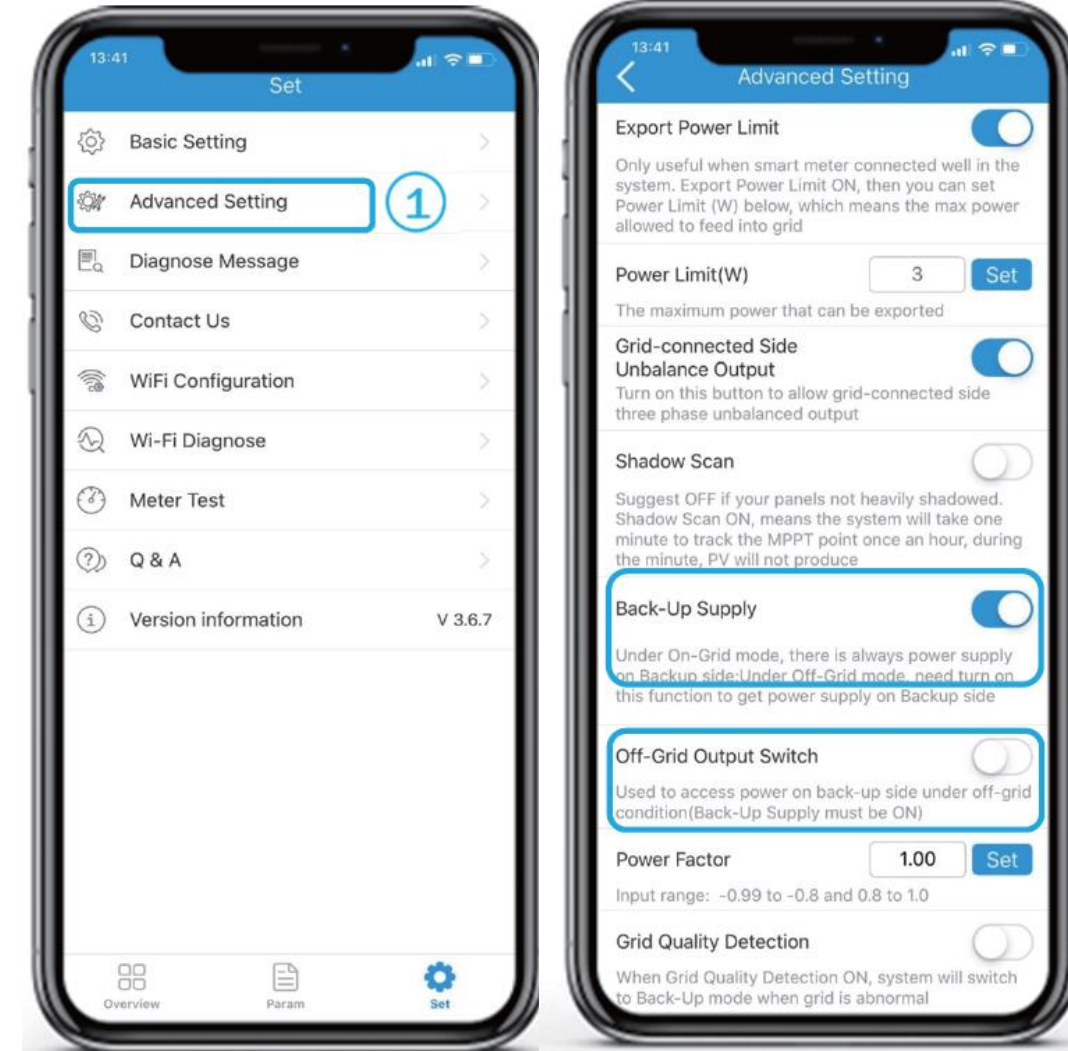

# Ongebalanceerde 3-Fase uitgang

- Klik op “Advanced Setting”
- Schakel “Grid-connected Side Unbalance Output” in



1. Voor Android telefoon:
  - Schakel “Vliegtuigmodus” in
  - Zet dan alleen “Wifi” aan

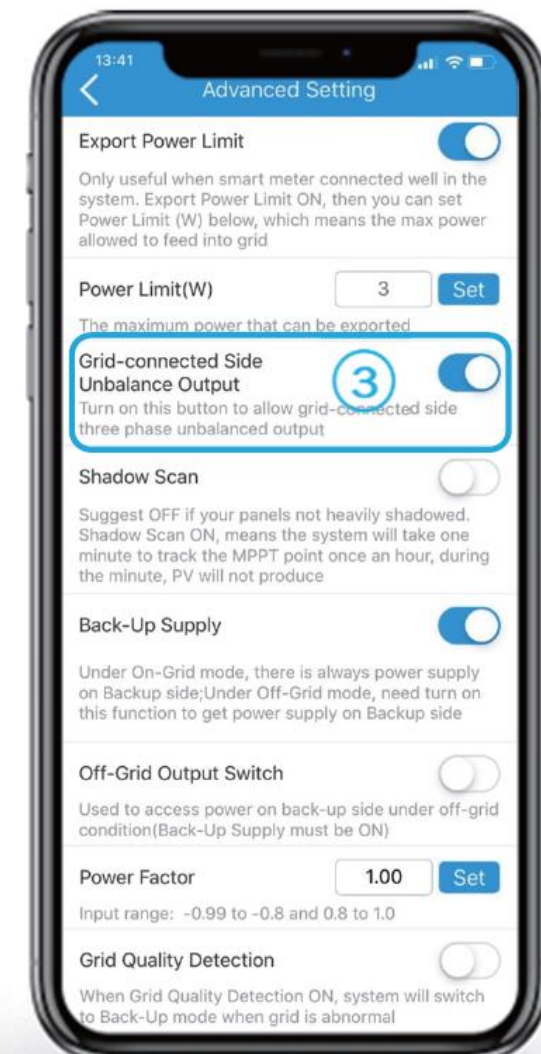
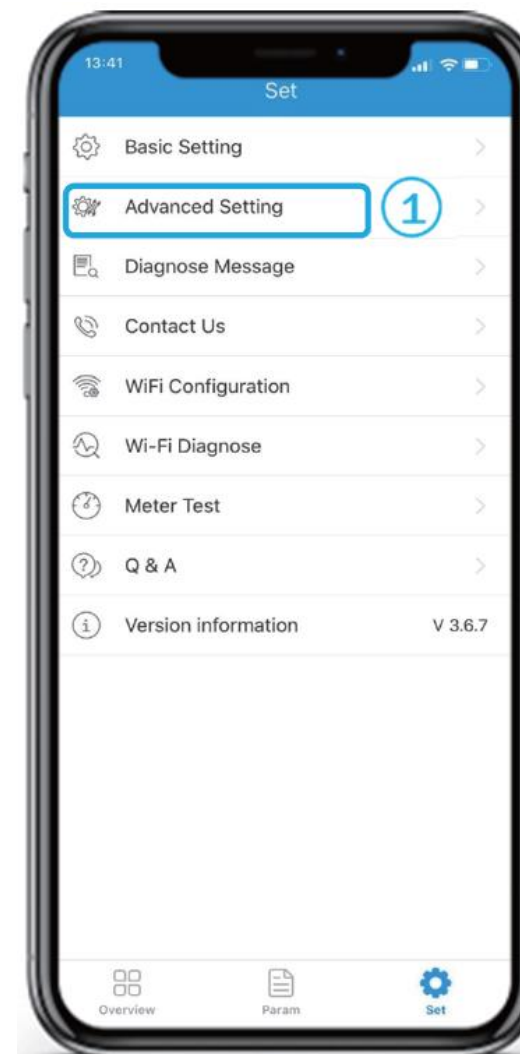

# Omvormer Inbedrijfstelling- Voltooien

- Controleer het scherm “Overview” om de status van apparaten te controleren - VOLTOOIEN

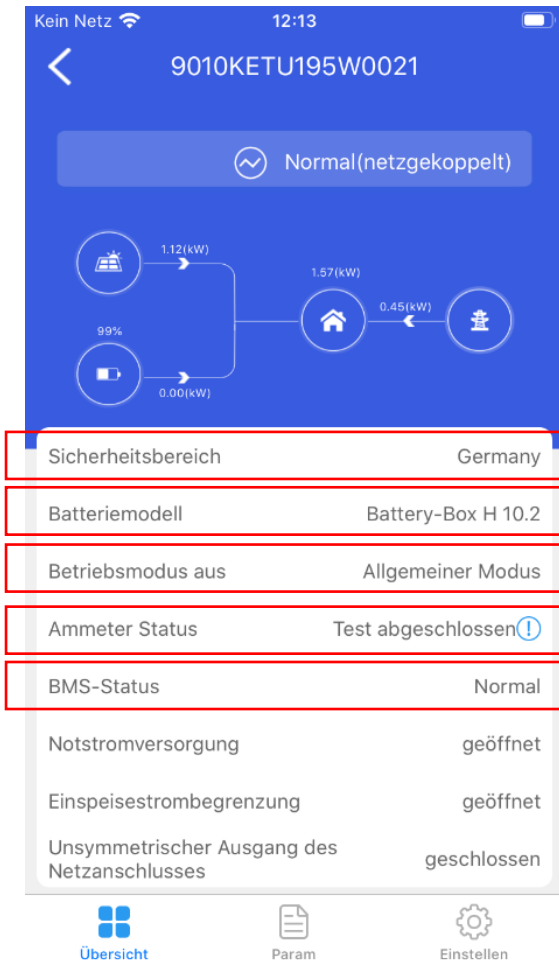

# Internet Setup



# Verbinding maken met router- Laptop

- Verbind de PC met het “Solar-Wifixxxx” toegangspunt
- Open webbrowser en voer in:
  - <http://10.10.100.253>
  - Login: admin
  - Password: admin

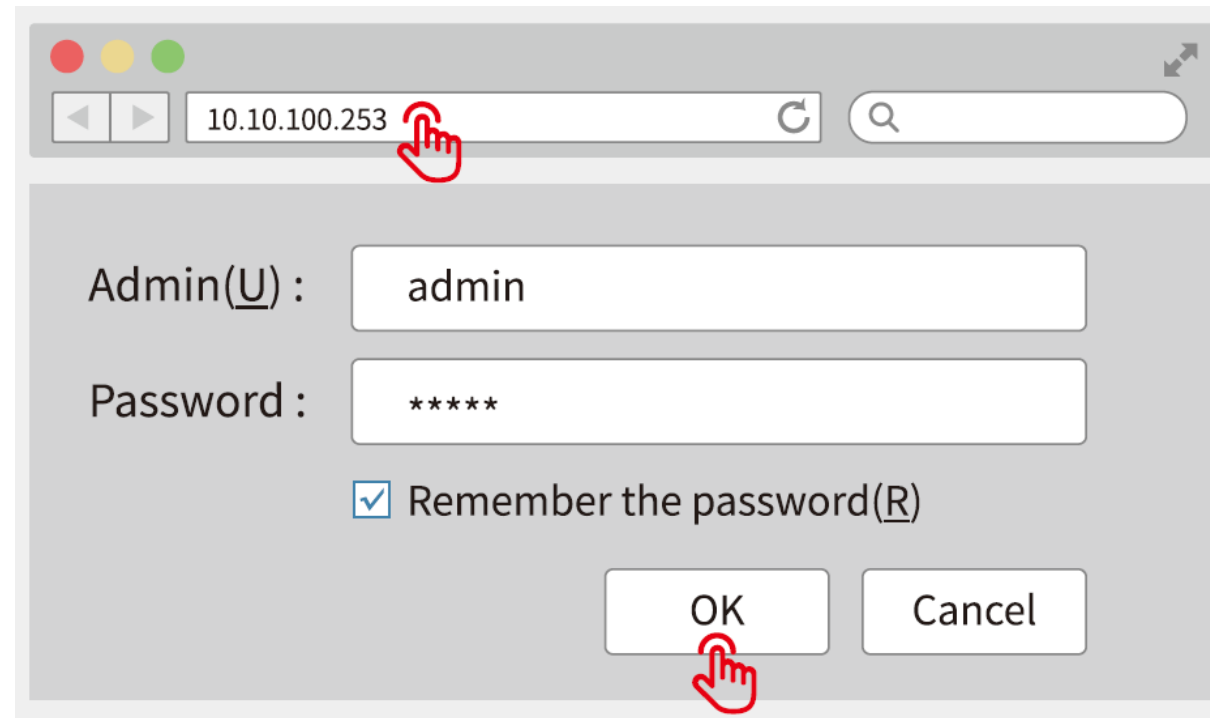

# Verbinding maken met router- Laptop

- Klik op “Start Setup”
- Selecteer de juiste “wireless network”
- Voer het wachtwoord van het draadloze network in
- Klik op “Complete”



Observeer omvormer Wifi “LED”

## Device information

Firmware version	1.6.9.3.38.2.1.38
MAC address	60:C5:A8:60:33:E1
Wireless AP mode	<b>Enable</b>
SSID	Solar-WiFi
IP address	10.10.100.253
Wireless STA mode	<b>Disable</b>
Router SSID	WiFi_Bum-in
Encryption method	WAP/WAP2-PSK
Encryption algorithm	AES
Router Passowrd	WiFi_Bum-in

Cannot join the network, may be caused by:

**No router / weak WiFi signal / password is not correct**

★ **Help:** Wizard will help you to complete setting with one minute.

Start Setup



## Please select you current wireless network

	SSID	AUTH/ENCRY	RSSI	Channel
<input type="radio"/>	WiFi_Bum-in	WPAPSKWPA2PSK/TKIPAES	66	1
<input type="radio"/>	WiFi_Bum-in	WPAPSKWPA2PSK/TKIPAES	100	1
<input type="radio"/>	WiFi_Bum-in	WPAPSKWPA2PSK/TKIPAES	70	1
<input type="radio"/>	WiFi_Bum-in2	WPAPSKWPA2PSK/TKIPAES	72	1

Refresh

★ **Help:** When RSSI of the selected Wi-Fi network is lower than 15%, the connection may be unstable. Please select other available network or shorten the distance between the device and router. If you wireless router does not broadcast SSID, please click "Next" and add a wireless network manually.

Back





Next

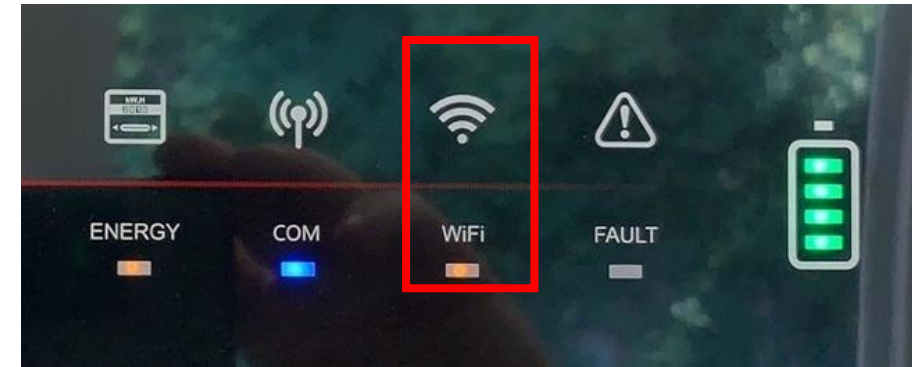

# Verbinding maken met router- Laptop

- Licht indicatoren – gevonden in de handleiding



<b>WiFi</b>		ON = WiFi connected / active
		BLINK 1 = WiFi system resetting
		BLINK 2 = WiFi not connect to router
		BLINK 4 = WiFi server problem
		OFF = WiFi not active

# SEMS Portal



# SEMS Portal: Startpagina

[www.semsportal.com](http://www.semsportal.com)

**GOODWE** | **SEMS**  
YOUR SOLAR ENGINE

Demo | Operation Guide | GDPR Contacts | Language-English ▾

**SEMS**

ENTER A NEW ERA OF SMART ENERGY

[Log In](#) [Register](#)

Remember [Forgot password?](#)

Dear customers,  
We cordially invite you to join our GoodWe Photo Contest and win \$10,000 worth of Amazon gift cards for the rest of 2020. For more details, please click [Registration Instructions](#) to see the news.  
Don't forget to follow us on the social media to join our contest! (Facebook, LinkedIn, Instagram, Twitter)

SEMS Portal

EzDesigner2 | GOODWE

# SEMS Portal: Startpagina

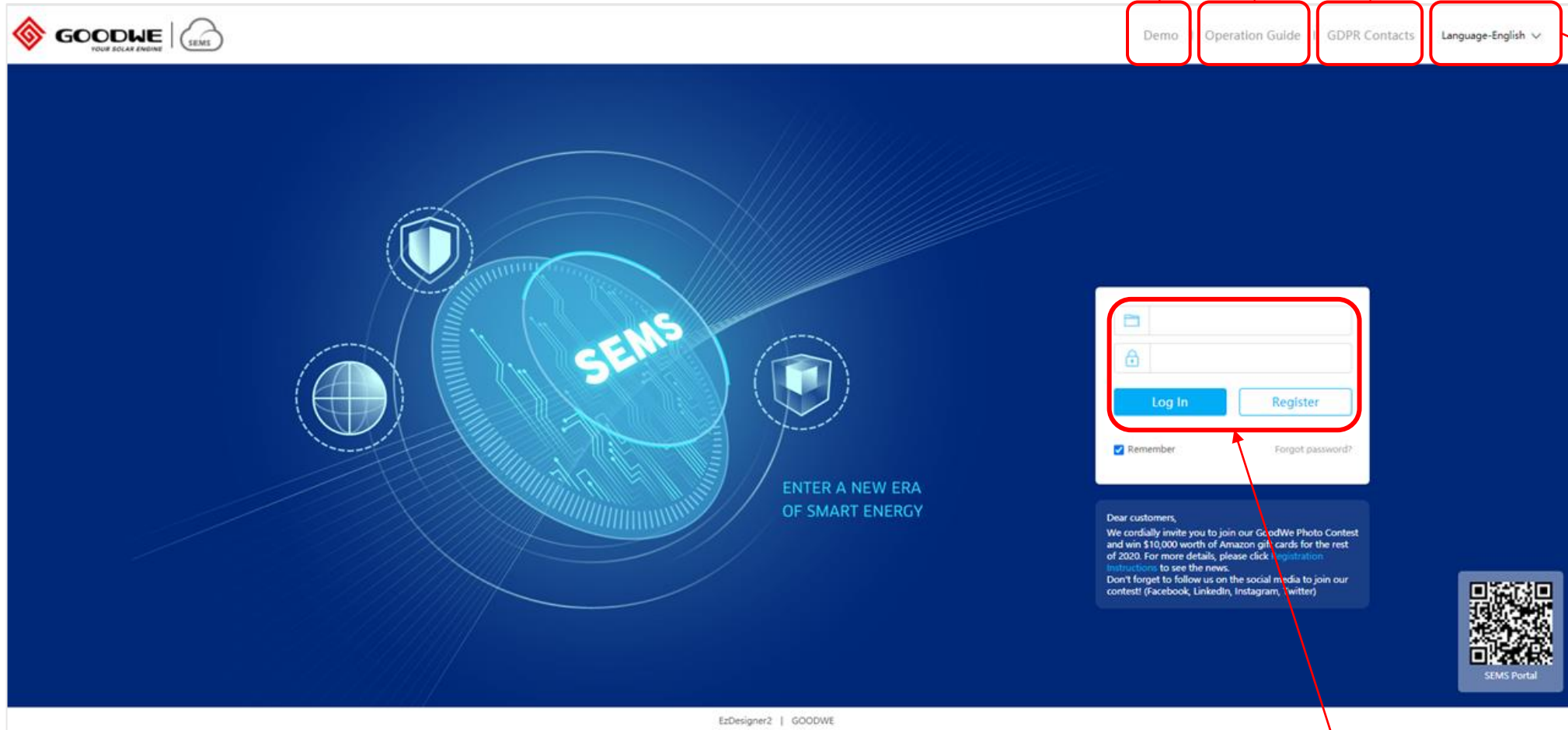

Demo PV Plants

Bedieningshandleiding

GDPR info

- Demo
- Operation Guide
- GDPR Contacts
- Language-English

Language-English

Language-English

Language-Español

Language-Português

Language-Čeština

Language-Türkçe

Language-한국어

Language-Dutch

Language-Italiano

Language-ไทย

Language-Deutsch

Language-Polski

Language-Le français

Language-русский

Language-日本語

Log in

# SEMS Portal: Registreren

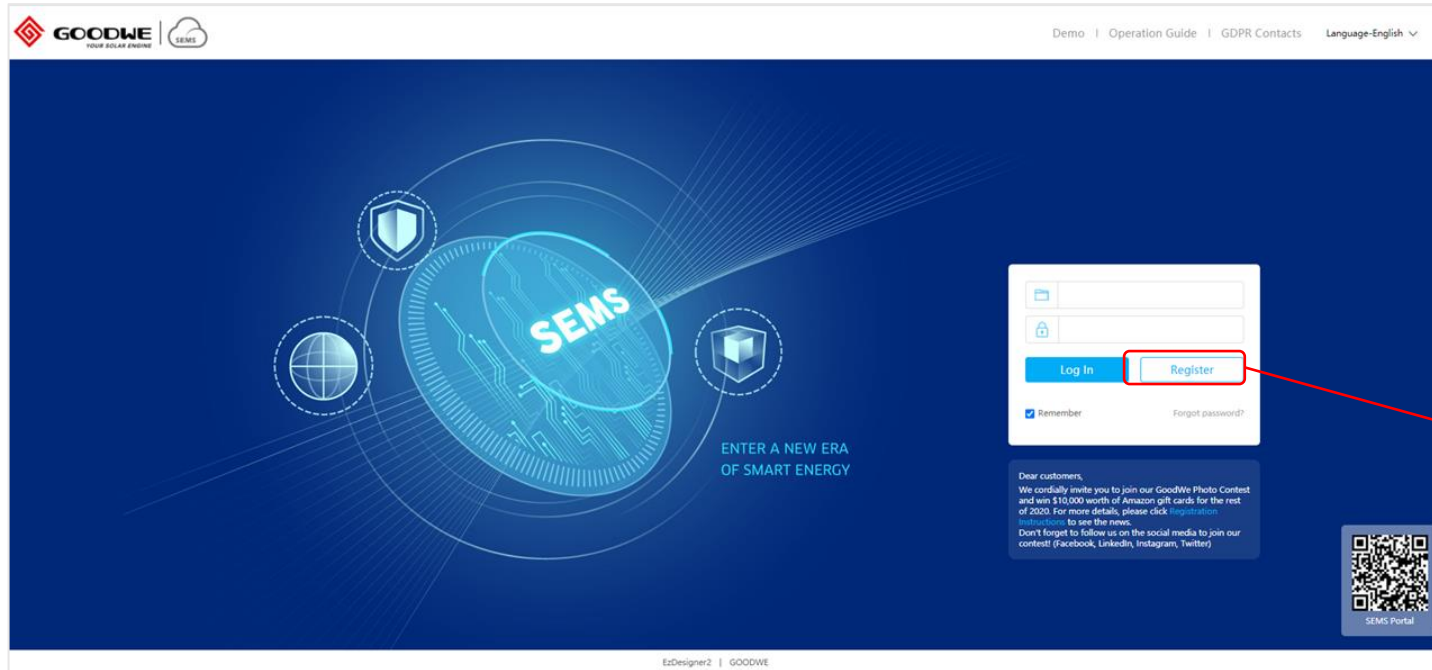

End user [Need a company account?](#)

\* E-mail

\* Password

\* Confirm

Should be 8-16 characters, include at least one letter and one number.

\* Area  AUS/NZ&Oceania  Europe  Other

I am an adult, I have read and agree to the following terms.  
[GOODWE Terms of Use](#)  
[GOODWE Portal Data Protection Statement](#)

\* Required content

# SEMS Portal: Informatie PV installatie



Basissysteem-gegevens

Weerbericht

Gekoppelde apparaten

Apparaatgegevens



Huidige vermogen

Totaal pictogrammen

Systeemgrafieken: PV, Belasting, Meter,..

# SEMS Portal – Hoe maakt u een PV installatie aan

# SEMS – Een PV installatie aanmaken:

Klik op “Create Plant”

The screenshot shows the SEMS Portal interface. At the top, there is a navigation bar with the following tabs: **GOODWE YOUR SOLAR ENGINE**, **SEMS SEMS PORTAL**, **Plants Status**, **Alarms**, **Reports**, and **Create Plant** (highlighted with a red box and an arrow). On the right side of the navigation bar, there are links for **Main Dashboard**, **Logout**, and **Settings**.

Below the navigation bar, there are search bars for **Location** (Global), **Organization** (Distributor code), and a general search bar (Please enter plant / SN / Email). There are also four summary cards:

- Statistics of Status**: 41379 (green), 60828 (grey), 5223 (orange), 137 (red).
- New Plants in This Month**: 3512 (Plants), 25301.15 (kW).
- Today Generation & Income**: 76.33 MWh, 542280.04 (EUR).
- Total Generation & Income**: 570.42 GWh, 5451.20 (M EUR).

Below the cards, there are status filters: **Fault** (red), **Offline** (grey), **Waiting** (orange), and **Generating** (green).

The main content area features a table with the following columns: **Plant**, **Location**, **Power**, **Capacity**, **kWh/kWp**, **Today**, **Monthly**, **Total**, and **Classification**.

Plant	Location	Power	Capacity	kWh/kWp	Today	Monthly	Total	Classification
● 't smikkelkje	Bredaseweg 58, 4702 KV Roos...	0.24kW	8.00kW	0.23	1.80kWh	215.60kWh	3841.50kWh	residential
● 't Genseler	Jasmijnstraat 15, 7552 AH, Hen...	2.28kW	84.32kW	0.30	25.00kWh	1540.40kWh	6701.40kWh	commercial rooftop
● 't Snuitje	Middegaal 26-28	0.12kW	4.40kW	0.25	1.10kWh	141.60kWh	11528.90kWh	residential
● (AS) B. Idema MI191022	12 Nienoordshaven, Drenthe, ...	0.04kW	2.48kW	0.36	0.90kWh	88.80kWh	1604.20kWh	residential
● (AS) Hilderink	Unnamed Road, 7811 EN Emm...	0.06kW	3.60kW	0.14	0.50kWh	13.70kWh	5499.70kWh	residential
● (AS) Stob 19352	Lotstukken 3, 9761 KC Eelde, ...	0.08kW	3.54kW	0.14	0.50kWh	72.90kWh	4133.40kWh	residential
● (AS) de Korte 19522	Bremstraat 263, 9404 GD Asse...	0.05kW	2.40kW	0.17	0.40kWh	53.80kWh	2539.70kWh	residential
● (BS) A.F. Ananias 18877	Drostlaan 8	0.04kW	2.48kW	0.16	0.40kWh	60.30kWh	5036.80kWh	residential
● (BS) C. Harmsen	Eikenweg 5, 9756 BR Glimmen,...	0.12kW	0.00kW	0.00	0.70kWh	54.90kWh	1049.60kWh	residential
● (BS) E. de Vos 19208	Hoofdweg 58D, Eelde	0.08kW	4.43kW	0.16	0.70kWh	87.30kWh	6610.80kWh	residential
● (BS) F. Baijer 19600	Voorhuis 85, 9205 BD Drachte...	0.11kW	3.15kW	0.16	0.50kWh	78.30kWh	3078.70kWh	residential
● (BS) Faber 19288	Schuur 5, 9205 BE Drachten, N...	0.08kW	2.95kW	0.10	0.30kWh	42.20kWh	3050.60kWh	residential
● (BS) G. Boverhof 18346	Zwanenbloem 10 Eelde	0.08kW	3.30kW	0.21	0.70kWh	67.20kWh	6512.30kWh	residential
● (BS) G. Schakel 19093	Poststraat 10 9571 CM Tweed...	0.06kW	3.54kW	0.20	0.70kWh	84.40kWh	6883.10kWh	residential

At the bottom of the table, there is a **Carousel ON** button and a pagination control showing **Previous**, **1**, **2**, **3**, **4**, **5**, **...**, **2951**, **Next**, **Jump to**, **1**, **Page**, and **Submit**.

# SEMS – Een PV installatie aanmaken:

Klik op “Add”

Email	Operation
<input type="text"/>	<a href="#">Cancel</a>

Het e-mailadres van de eigenaar  
invoeren

Optioneel – Gast toevoegen

Email	Operation
<input type="text"/>	<a href="#">Cancel</a>

Het e-mailadres van de gast invoeren

Klik op “Add”

# SEMS – Een PV installatie aanmaken:

Voer de installatiennaam in

Selecteer classificatie

- Residential: Alleen PV
- Commercial rooftop: Alleen PV
- Ground-mount: Alleen PV
- Battery Storage: Hybride

Voer financials in

\*Plant GW000000Pv plantB531

Creation Date 11/26/2019

\*Capacity Capacity kW

Classification residential

\*Location Location Map

Longitude Longitude Latitude Latitude

Detailed Address Detailed Address

Distributor code GW000000  
Keep it empty if you don't know the installer's code

\*Profit Ratio 0.038 EUR/kWh

Amount of solar panels 0

Enable Profile  Enable  Disable

Plant Profile  
Distributed PV power plant refers to the operation mode of "construction and operation at the user's site or nearby, and implementation of "self-use, excess power to grid, nearby consumption, and power grid adjustment" on the user side and in the distribution network system, the characteristics of photovoltaic power generation facilities are balanced and adjusted. Distributed photovoltaic power generation follows the principle of adapting to local conditions, clean and highly efficient, decentralized layout, and proximity utilization, making full use of local solar energy resources to replace and reduce fossil energy consumption. Without the use of fuel, the operating cost is very low; there are no moving parts, it is not easy to damage, maintenance is simple, especially suitable for use in unattended conditions; it will not produce any waste, no pollution, noise and other public hazards, no adverse impact on the environment, Outstanding environmental benefits. Distributed photovoltaic power generation is a new type of power generation and energy comprehensive utilization mode with broad development prospects. It can realize nearby power supply without long-distance transmission

Cancel Submit

Voer de capaciteit van de PV generator in kW in

Voer het aantal zonnepanelen in



# SEMS – Locatie:

Adres invoeren  
of  
Rode markering  
verplaatsen –  
in- en uitzoomen op de  
kaart

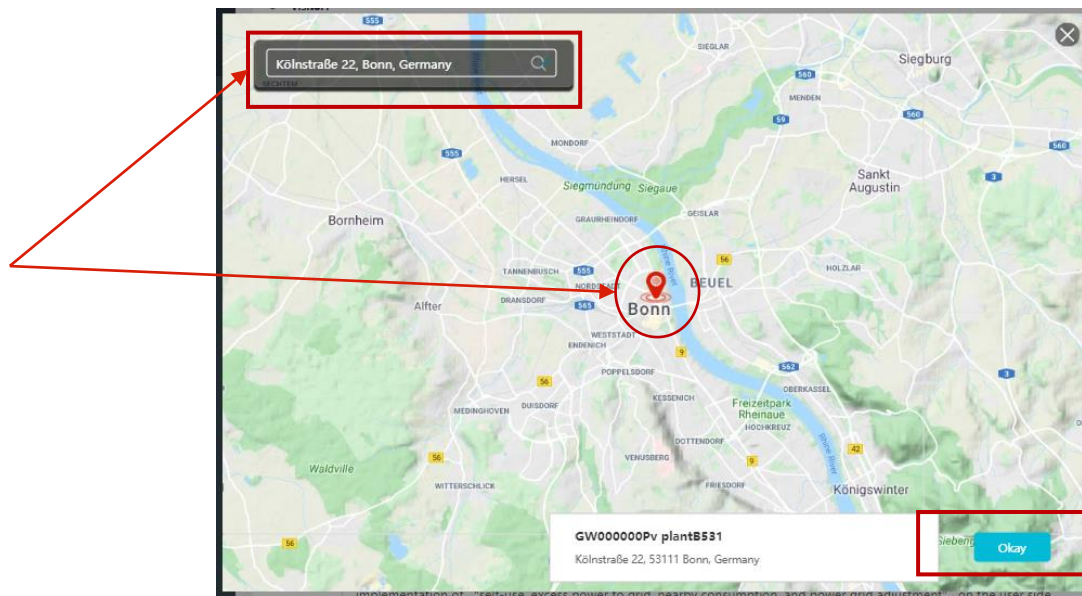
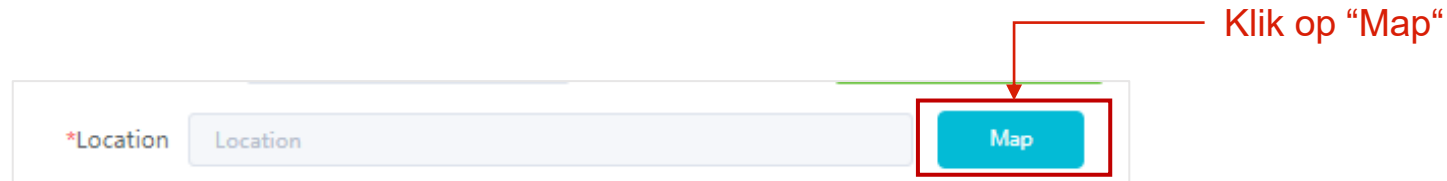

Selectie via kaart zorgt voor een  
correcte weersvoorspelling

Klik op OK

Ignore  
Als de locatie juist is  
**To Re-locate**  
Als de locatie onjuist is

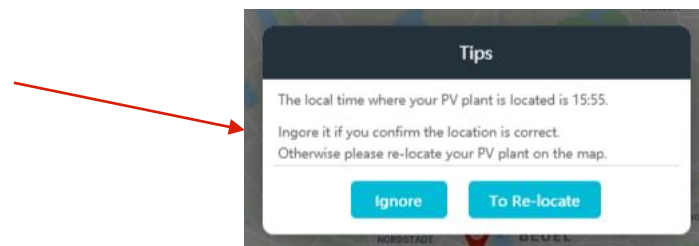

# SEMS – Distributeurcode:

\*Plant: GW000000Pv plantB531  
Creation Date: 11/26/2019  
\*Capacity: 5 kW  
Classification: residential  
\*Location: Kölnstraße 22, 53111 Bonn, Germany  
Longitude: 7.100978899999973  
Latitude: 50.7387587  
Detailed Address: Detailed Address  
Distributor code: GW000000  
Keep it empty if you don't know the installer's code  
\*Profit Ratio: 0.038 EUR/kWh  
Amount of solar panels: 12  
Enable Profile:  Enable  Disable  
Plant Profile: Distributed PV power plant refers to the operation mode of "construction and operation at the user's site or nearby, and implementation of "self-use, excess power to grid, nearby consumption, and power grid adjustment" on the user side and in the distribution network system, the characteristics of photovoltaic power generation facilities are balanced and adjusted. Distributed photovoltaic power generation follows the principle of adapting to local conditions, clean and highly efficient, decentralized layout, and proximity utilization, making full use of local solar energy resources to replace and reduce fossil energy consumption. Without the use of fuel, the operating cost is very low; there are no moving parts, it is not easy to damage, maintenance is simple, especially suitable for use in unattended conditions; it will not produce any waste, no pollution, noise and other public hazards, no adverse impact on the environment, Outstanding environmental benefits. Distributed photovoltaic power generation is a new type of power generation and energy comprehensive utilization mode with broad development prospects. It can realize nearby power supply without long-distance transmission

Cancel Submit

Vooraf ingevuld voor  
installatieaccounts

Als de huiseigenaar een PV  
installatie installeert dan moeten  
ze de „distributor code“ of  
„installer code“ invoeren

Klik op "Submit"

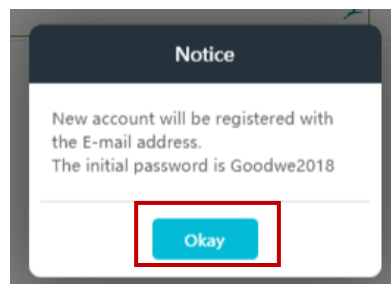

Het e-mailadres van de PV-eigenaar wordt automatisch  
geregistreerd  
Klik op "Okay"

# SEMS – Een PV installatie aanmaken: Apparaat toevoegen

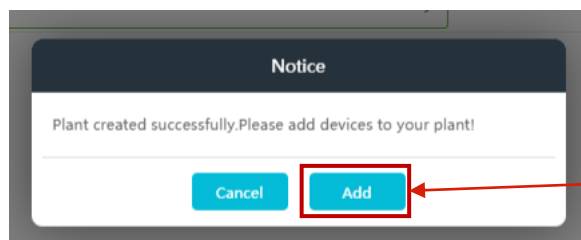

Klik op "Add"

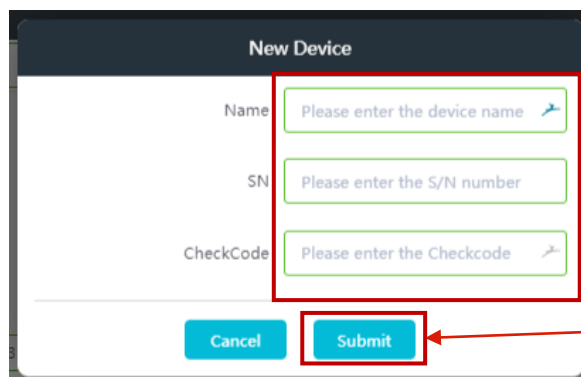

Optioneel: Naam apparaat- Alias

SN: Serienummer invoeren

CheckCode: op het label van de omvormer

Klik op "Submit"

PV Installatie toegevoegd aan lijst

Plant	Location	Power	Capacity	kWh/kWp	Today	Monthly	Total	Classification
● 't smikkeltje	Bre	0.04kW	8.00kW	0.25	2.00kWh	215.80kWh	3841.70kWh	residential
● 't Genseler	Jas	0.01kW	84.32kW	0.31	25.90kWh	1541.30kWh	6702.30kWh	commercial rooftop
● 't Snuitje	Mi	0.07kW	4.40kW	0.27	1.20kWh	141.70kWh	11529.00kWh	residential
● (AS) B. Idema MI191022	12	0.00kW	2.48kW	0.36	0.90kWh	88.80kWh	1604.20kWh	residential
● (AS) Hilderink	Un	0.04kW	3.60kW	0.17	0.60kWh	13.80kWh	5499.80kWh	residential



**GOODWE**  
*YOUR SOLAR ENGINE*



**Bedankt!**