



Smappee EV Line Installation Training

Agenda

- Smappee Smart Charging
- Overzicht EV-laadpunt varianten
- Installatie en indienststelling procedure van de EV Wall (Home)
- Aandachtspunten 3x230V (Delta)
- Wrap-Up na installatie - Overdracht App-toegang naar eindklant
- Smappee Partner Dashboard:
 - Remote opvolging, validatie & configuratie-mogelijkheden
 - Activatie bijgeleverde Smappee RFID-card
- Verschil met Business varianten
- Quotatie & configurator

Consumption analysis

Available in the Smappee App:

- Total consumption and solar production
- Always-on (standby) consumption
- Cost analysis (down to the appliance level)

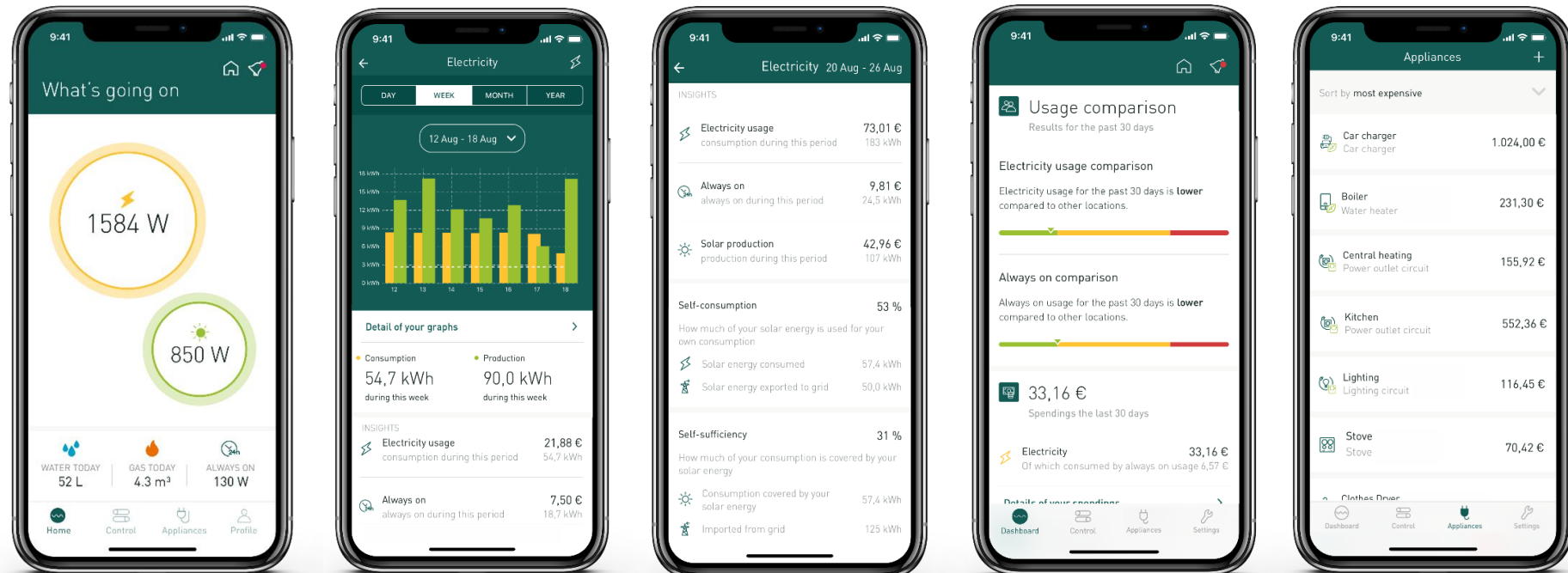

Smappee Dashboard

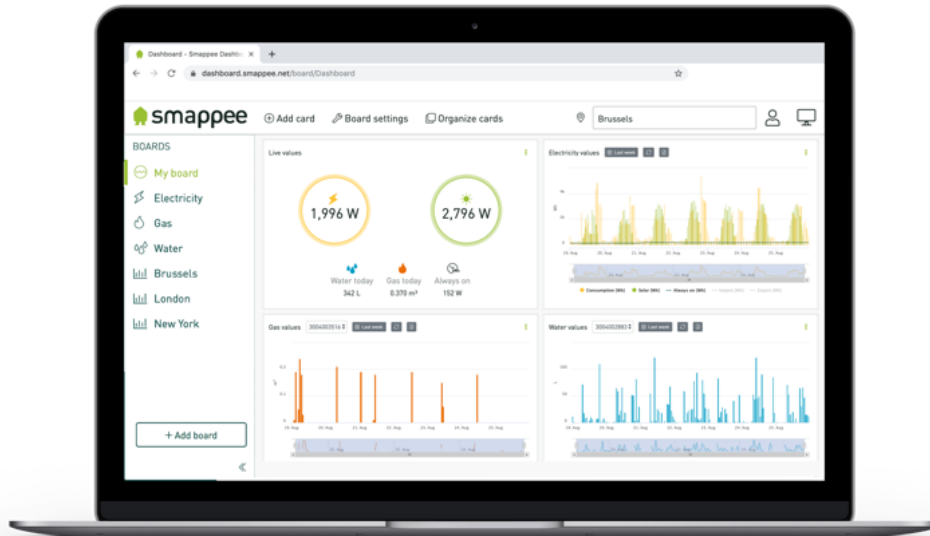

- Real-time and historical data
- Energy, solar, gas & water
- Submetered appliances
- Data across multiple sites in one place
- Channel & CT configuration
- Tailor the dashboard to your needs by adding 'Cards'
- Export data as .CSV file
- Includes 1st line support tool
- Possible to add you logo and branding

Architecture – Partner vs. end customer

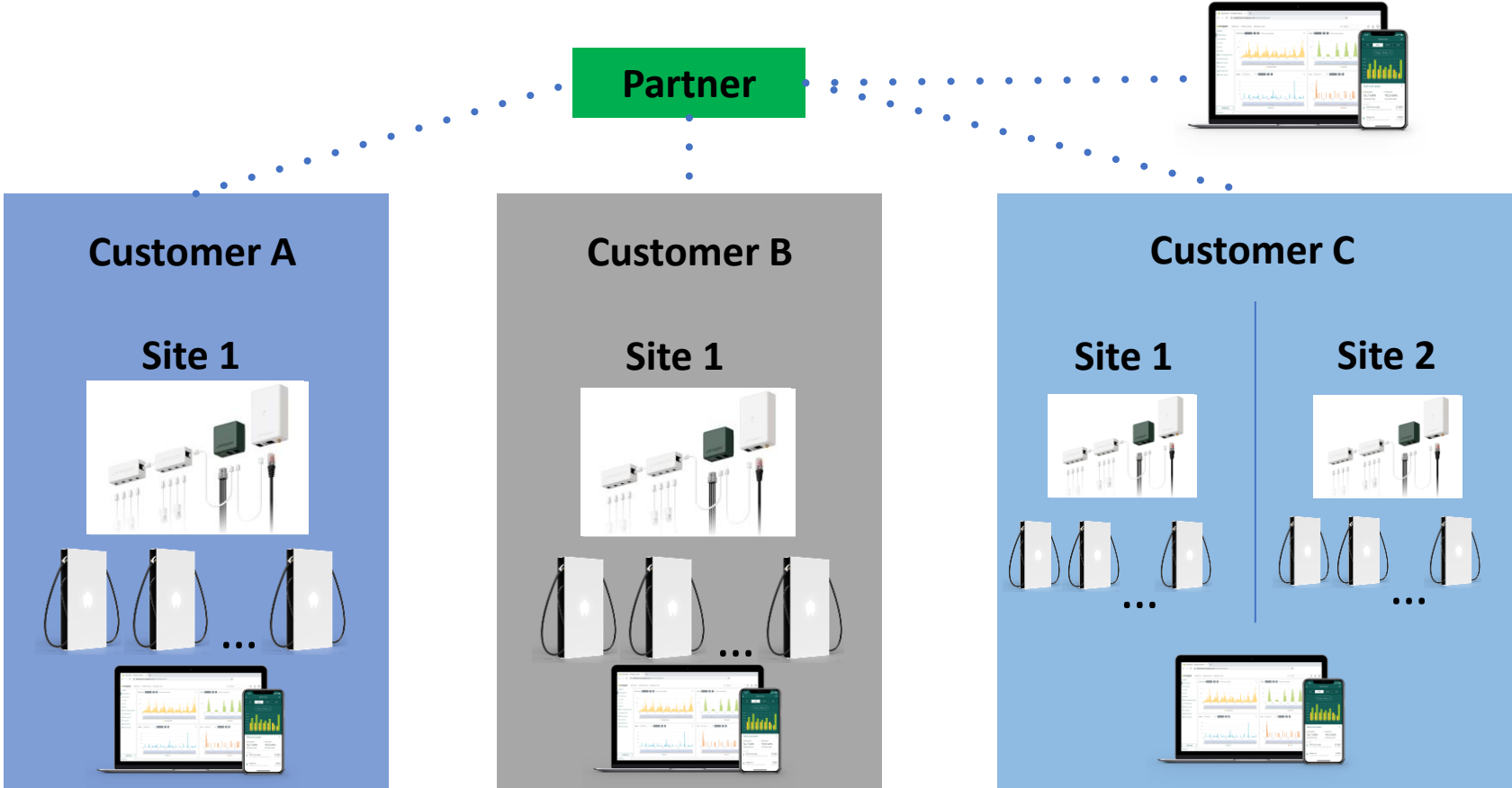

Dynamic load balancing with Smappee Infinity

Overload protection – Circuit Breaker protection

What: Smappee reduces power of each charging point to protect installation from overloads.

How:

- Maximum allowed power of the car charging point is adjusted in real time to protect the main circuit breaker, based on:
 - Real time total consumption of the site
 - Maximum current of main circuit breaker (set point)
- Dynamic aspect:
 - depending on active charge points, charging session time and their actual consumption
 - based on Priority Settings per user (user group) – see later
- Enables:
 - Maximize amount of charging points or oversize maximum charge current of charging points on existing electrical installation
 - No need for higher rated grid connection
 - Peace of mind that all chargers can be operated safely even with more frequent use
 - Cost savings by keeping existing building power connection

Dynamic load balancing with Smappee Infinity

Optimization by self-consumption/sufficiency increase and cost reduction



What:

- Charging schedule adapted to charge with renewable energy
- Import energy as lowest tariff rate

How:

- Predicted solar production & consumption via AI: forecast & real time data
- Need of the EV-driver (charged for # km by a certain time)
- Cost (multi-tariffs & dynamic tariffs)



The user indicates through Smappee App:

- how long he will be on-site and
- how many kWh needs to be charged.



To ensure EV-driver comfort, interaction and input of 'charged for # km by a certain time' is required.

Dynamic load balancing with Smappee Infinity

Need of the EV-driver (charged for # km by a certain time)

Residential: House owner sets smart charging schedules for each day of the week providing time of departure and required charged distance

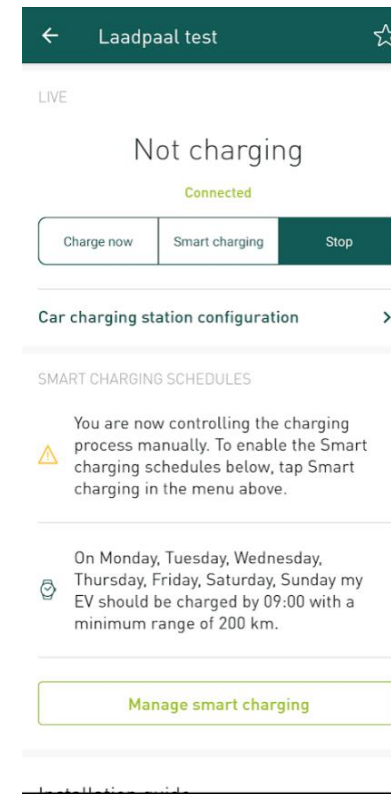
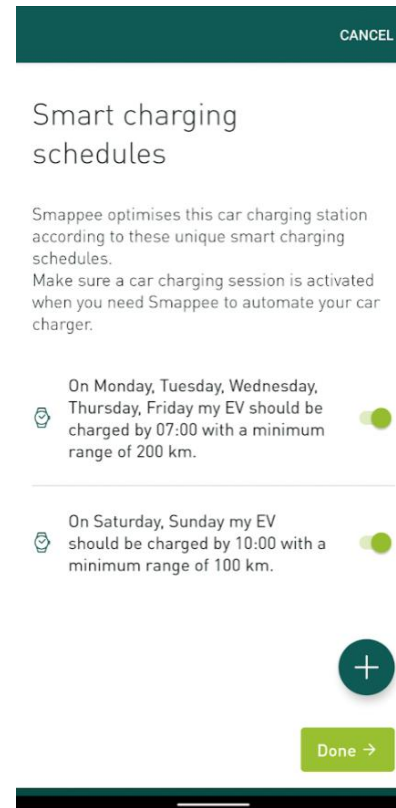

Demo movie: <https://www.youtube.com/watch?v=BJw1-0MDgv4>

Dynamic load balancing with Smappee Infinity

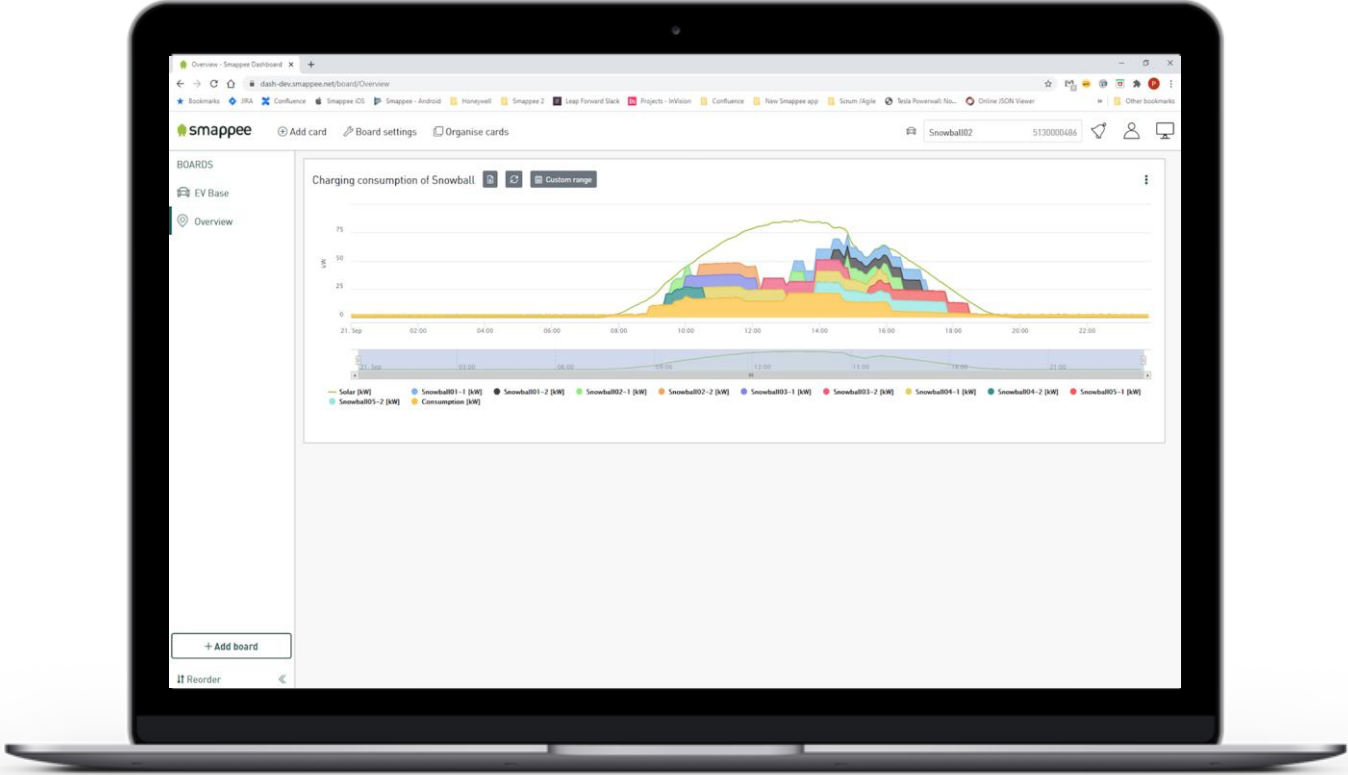



Installation procedure

EV Wall

(residential)

Smappee EV Line

Home	Business	
 <p data-bbox="675 488 930 516">Smappee EV Wall</p> <ul data-bbox="479 782 853 888" style="list-style-type: none">• Energy and charging data• Overload protection• Solar optimisation <p data-bbox="479 931 930 1002">Infinity & Smart Charging Package included!</p> <p data-bbox="479 1168 1014 1230">Internet connectivity at the distribution panel</p> <ul data-bbox="479 1245 789 1310" style="list-style-type: none">• Ethernet (preferred)• 2.4 GHz Wi-Fi	 <p data-bbox="1235 488 1490 559">Smappee EV Wall Business</p> <ul data-bbox="1057 782 1286 853" style="list-style-type: none">• Charging data• MID metering <p data-bbox="1057 896 1508 968">Infinity & Smart Charging Package need to be purchased separately:</p> <ul data-bbox="1057 973 1477 1116" style="list-style-type: none">• Energy data• Overload protection• Solar optimisation• Extension to 5 year warranty <p data-bbox="1057 1168 1498 1202">Internet connectivity for the unit</p> <ul data-bbox="1057 1210 1274 1239" style="list-style-type: none">• Ethernet only	 <p data-bbox="1923 488 2076 559">Smappee EV Base</p> <ul data-bbox="1625 782 1854 853" style="list-style-type: none">• Charging data• MID metering <p data-bbox="1625 896 2076 968">Infinity & Smart Charging Package need to be purchased separately</p> <ul data-bbox="1625 973 2051 1116" style="list-style-type: none">• Energy data• Overload protection• Solar optimisation• Extension to 5 year warranty <p data-bbox="1625 1168 1911 1202">Internet connectivity</p> <ul data-bbox="1625 1210 2012 1316" style="list-style-type: none">• Ethernet (preferred)• 2.4 GHz Wi-Fi (alternative)• 4G (contact Smappee)

Smappee EV Line

Home



Smappee EV Wall

- Energy and charging data
- Overload protection
- Solar optimisation

Infinity & Smart Charging Package included!

Use only for residential installations.

	EV Wall (Home) can only be used for: <ul style="list-style-type: none">• Residential installations• New installations that have no Infinity installed yet.
	If multiple EV Wall (Home) unit are needed in residential environment, use a second charging point the EV Wall Business.
	EV Wall (Home) does not support the use of Output module or other Infinity accessories (Switch, Gas & Water monitor, Input module)
	EV Wall (Home) can be extended with additional CT Hubs & CT's for metering.

EV Wall – Home

The EV Wall comes in the package with the required Smappee Infinity components to be installed in the distribution panel:

Single Phase Edition

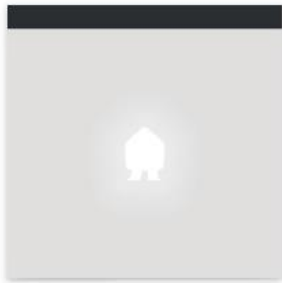

EV Wall



EV Wall mounting plate



EV Wall splitter



DIN mounting plate



Connect



Wall mounting plate



CT Hub



CT 50A



RJ10 cable
40 mm



RJ10 cable
150 mm



Bus termination
plug



Screw & plug



Small screw

Three Phase Edition

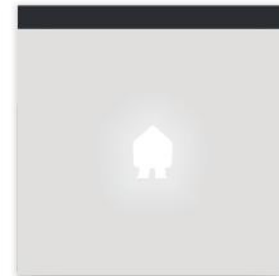

EV Wall



EV Wall mounting plate



EV Wall splitter



DIN mounting
plate



Connect



Wall mounting
plate



CT Hub



CT 50A



Solid Core
3-phase CT



Bus terminatic
plug



RJ10 cable
40 mm



RJ10 cable
150 mm



Screw & plug



Small screw

EV Wall – *Home*

At the location of each EV Line unit, foresee:

- 1x power supply cable **per connector** (1x EV Wall)
- 1x CAT 5/6 UTP communication cable:
 - EV Wall Business & EV Base: providing internet connection
 - **EV Wall (Home): going to distribution panel where Infinity components are to be installed**

Each EV Line **connector** has a separate differential protection:

- Diff. Type A – 30 mA AC
- RCM 6 mA DC



Wi-Fi connection properties

- **2.4 GHz** Wi-Fi required, preferably with automatic channel selection.
- Networks without DHCP server are not supported.
- WPA or WPA2 encryption mandatory.
- Networks without security are not supported.
- SSID must be visible and should not be hidden during installation.
- Not all characters are allowed in the SSID or Wi-Fi password
 - Allowed characters for SSID: [a-z],[A-Z],[0-9],[!#\$%&'()*+-./:;<>?@[]^_`{|}~]
 - Allowed characters for Wi-Fi password: [a-z],[A-Z],[0-9],[!"#\$%&'()*+-./:;<>?@[\]^_`{|}~]
- The maximum number of characters for the WPA2/PSK is 20.



The DHCP of your router assigns the IP address of your Smappee.



See Wi-Fi connection properties in Addendum 2 of the Infinity Installation manual.

Firewall rules

- Your firewall should allow Snappee to create outbound secure HTTP connections.
- No specific firewall settings are required in your network. If you use a firewall, use the commonly applied secure firewall rules:
 - Inbound communication: All inbound ports closed. No port forwarding.
 - Outbound communication: All outbound ports allowed.



See firewall rules in Addendum 2 of the Infinity Installation manual.

EV Wall – Connection diagram (1P+N)

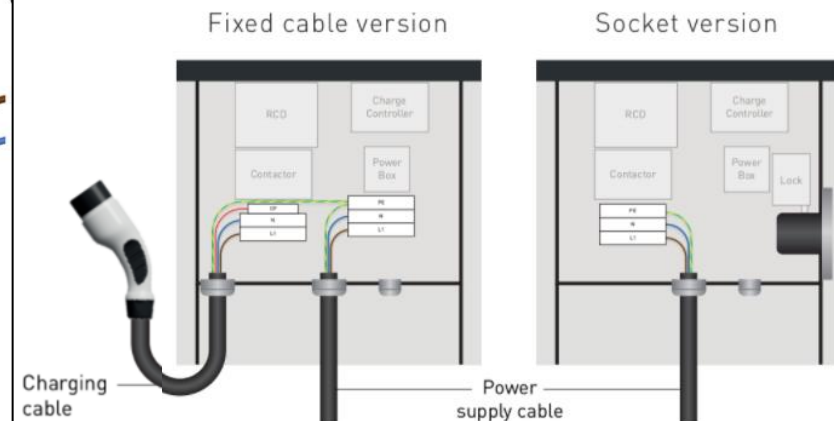
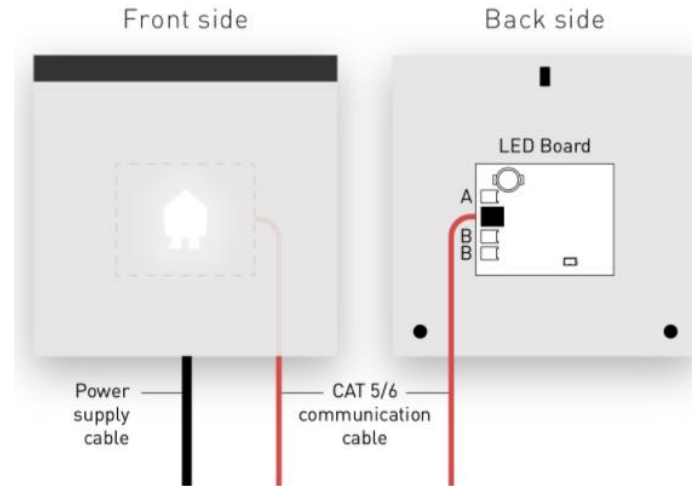
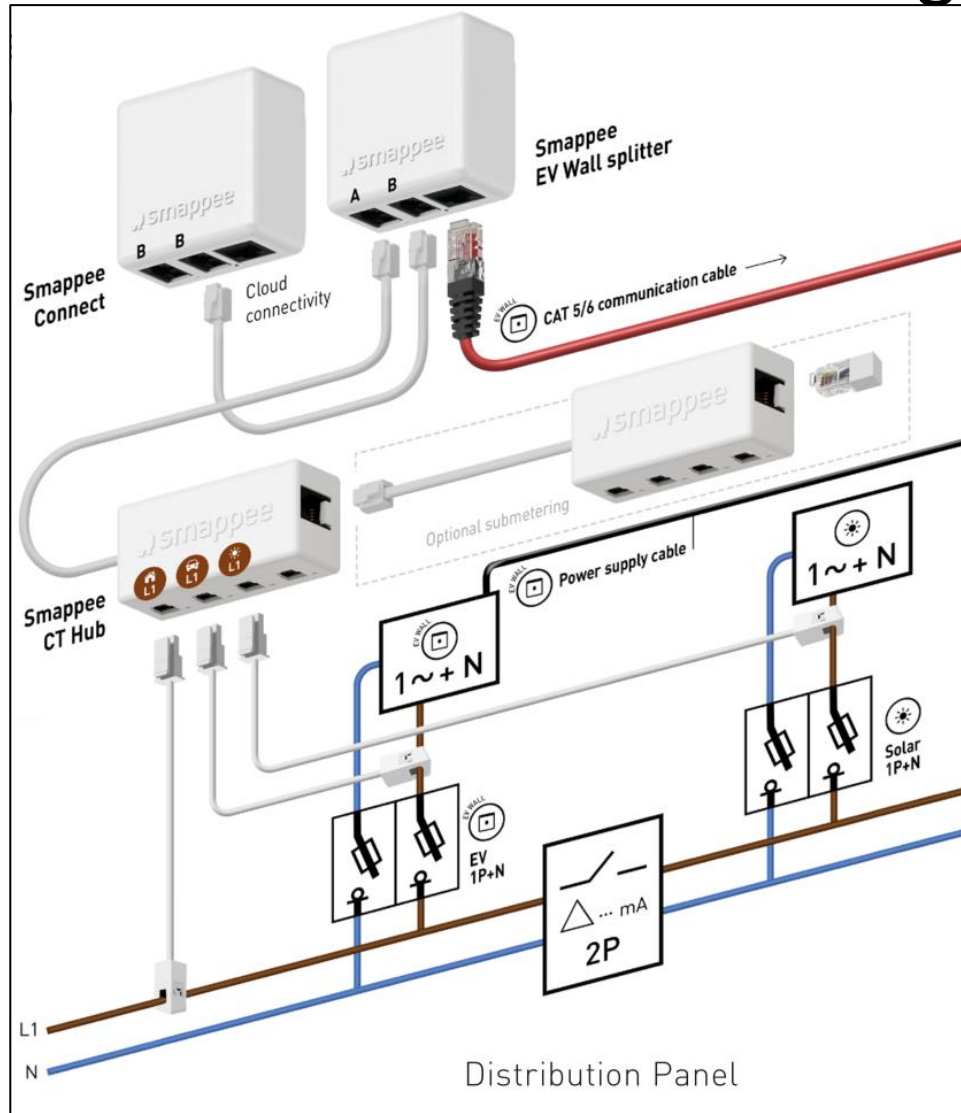

Step 2. Installation and activation

Power supply connection – Socket version

- Mount the power cable through the central cable gland (M32)
- Connect each supply cable to the connecting block and respect the phase-numbering:
 - L1, L2,L3,N to Diff. Type A
 - Ground (6 mm²) to connecting block

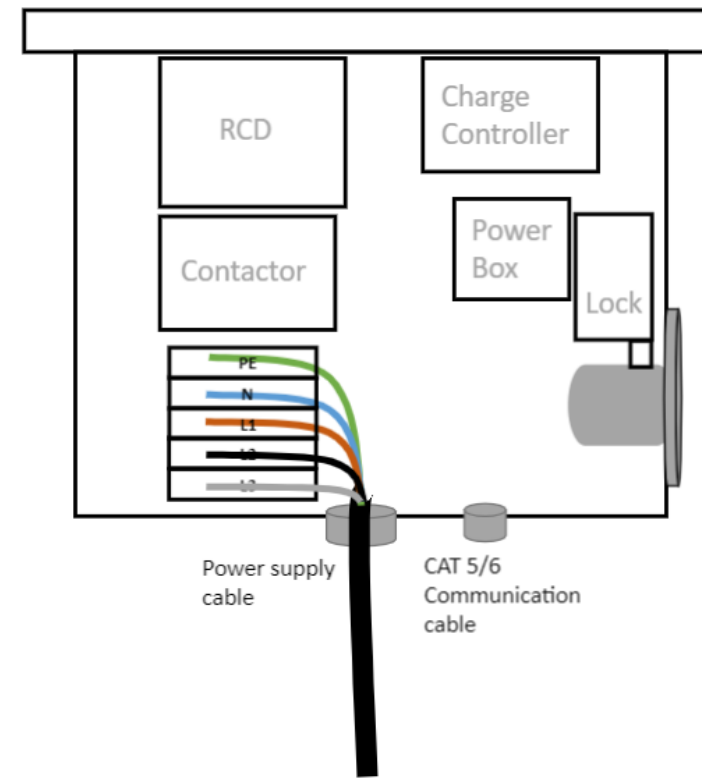
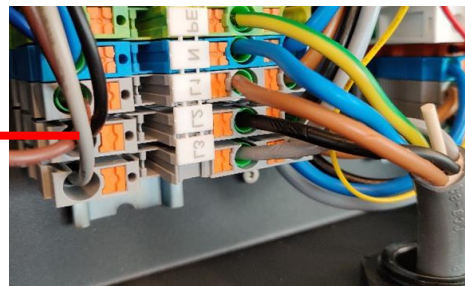
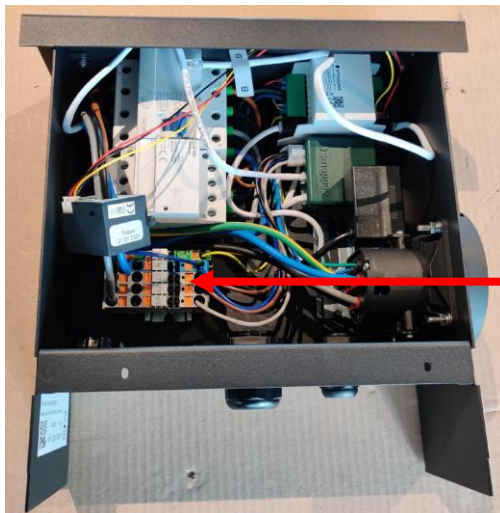

Step 2. Installation and activation

Power supply connection – Fixed cable version

- Mount the power cable through the central cable gland (M32)
- Connect each supply cable to the connecting block and respect the phase-numbering:
 - L1, L2,L3,N to Diff. Type A
 - Ground (6 mm²) to connecting block

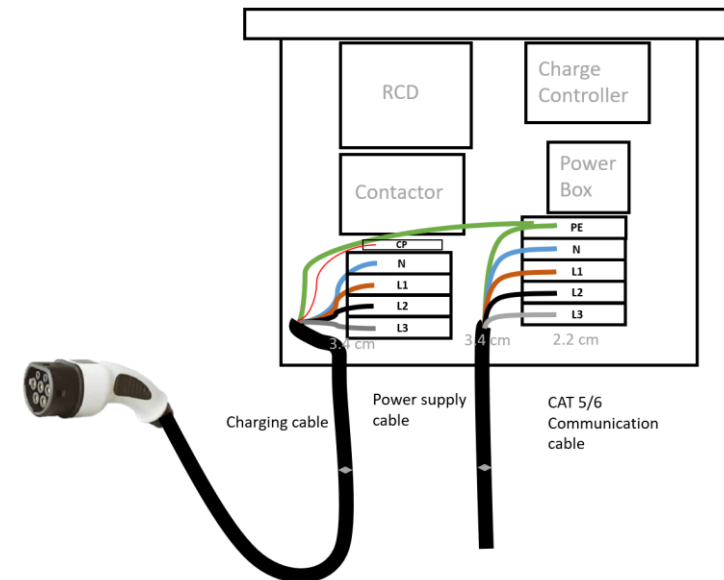
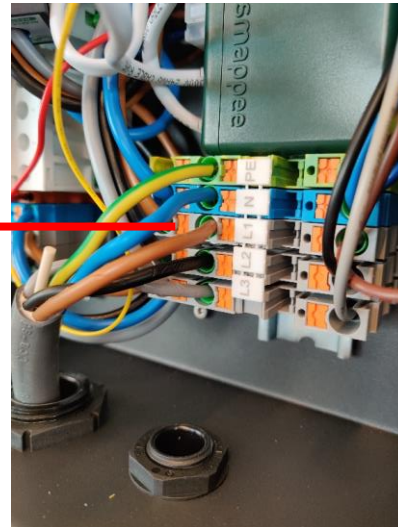
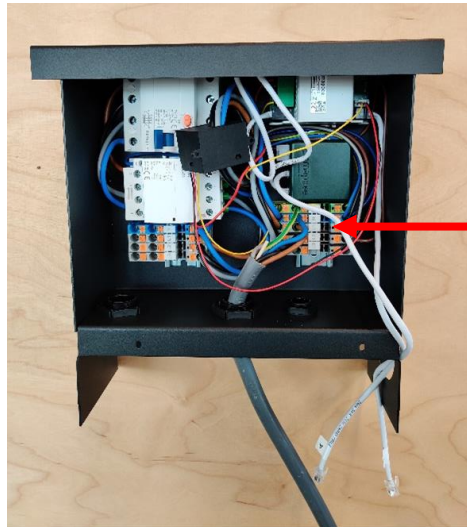

Step 2. Installation and activation

Closure

- Mount the front plate into position by connecting the RJ10 cables and Cat 5/6 cable to the PCB attached to the front plate.
- Pay attention to stickers and connect each cable to the corresponding input (A & B).

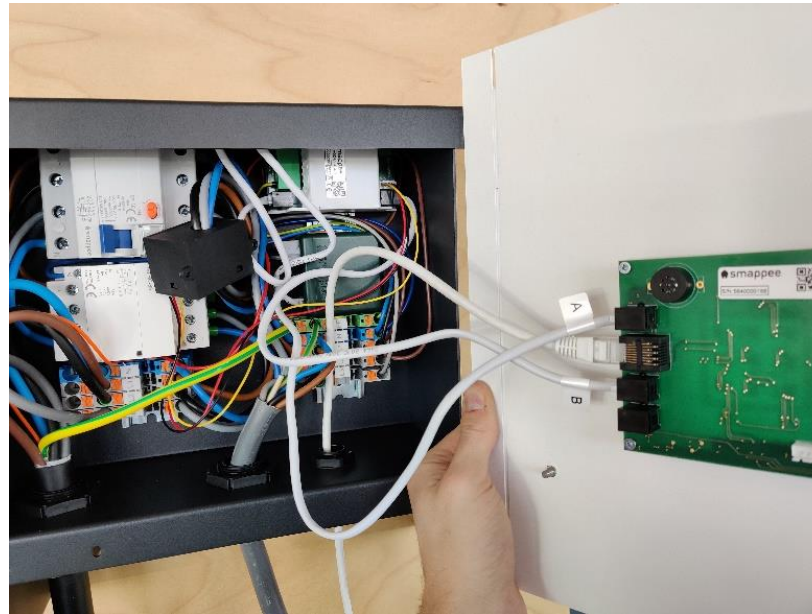

All communication cables must be attached to the front panel before powering the EV Wall. The EV Wall should also be closed.

Step 2. Installation and activation

Install Infinity components in distribution panel

Connect the current transformers (CTs) to phase wires of the main feeder



The arrow on the CT (K → L) indicates the direction of the current flow.

Step 2. Installation and activation

Install Infinity components in distribution panel

Connect the current transformers (CTs) to phase wires of the solar inverter.



The arrow on the CTs that measure solar have **to point away from the inverter**, towards the loads.

The direction is how the current of the produced energy flows.



Solar
(note the 'reversed' direction)



The arrow on the CT (K \square L) indicates the direction of the current flow.

Step 2. Installation and activation

Install Infinity components in distribution panel

Connect the CTs to the pre-configured CT Hub, matching each CT with its corresponding labelled input.



**Total Load
Home grid**



Car Charger

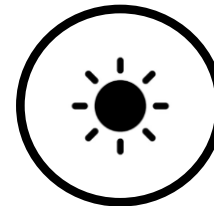

Solar

Step 2. Installation and activation

Install Infinity components in distribution panel

And connect the Solid Core 3-Phase CT for car charger.

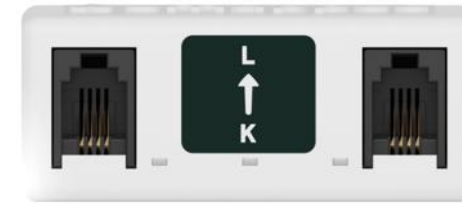
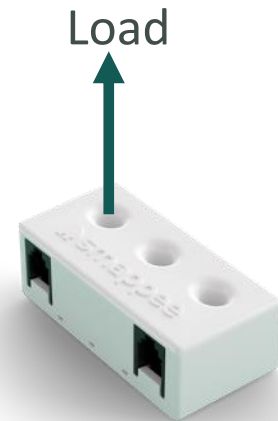

The arrow on the CT (K \uparrow L) indicates the direction of the current flow.

Important! Phase mapping check

Use a digital multi meter to determine by which phase the different loads are powered.

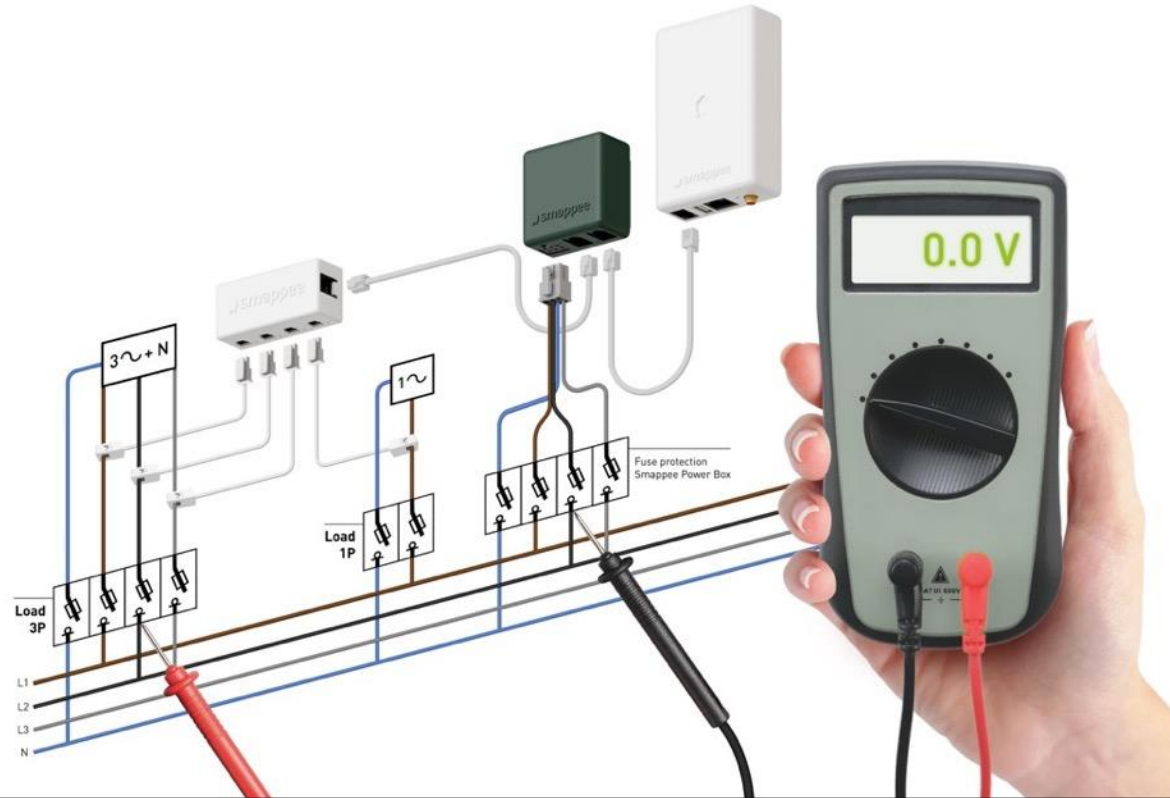
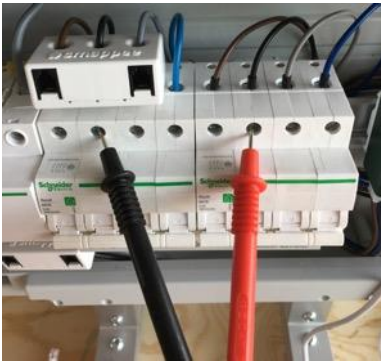

The colour code inside the fuse box and/or phase numbering can be false.

Step 2. Installation and activation

Example: 3x400V with PV 1x230V

Bus Terminal
CT 50A – Grid
Current measurement

CT 50A – Solar
Current measurement

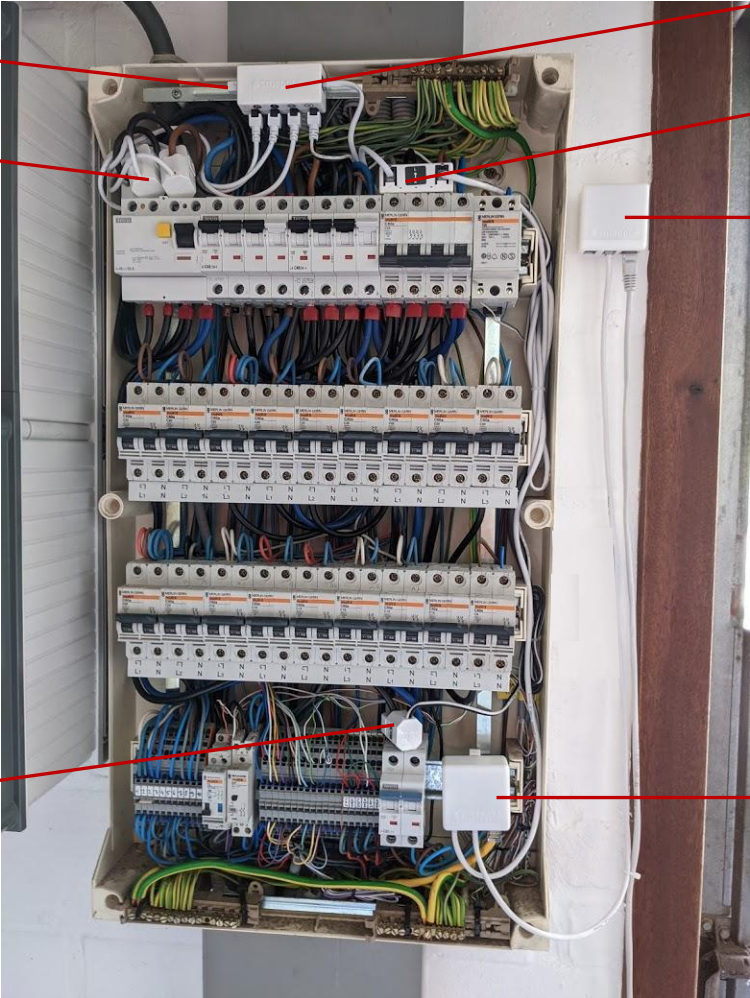

CT Hub
Total & Solar measurement
3-phase CT Hub
EV Charger measurement
Connect Gateway
Internet connection

EV Wall Splitter
Data cable from charger, to CT
Hub and Connect

Step 2. Installation and activation

Switching on the EV Wall

- Check all connections are secure and power-up the power supply of the EV Wall.
- Check the status LEDs:
 - Connect gateway – Blue blinking (1x per second)
 - Power Box – Pulsing 1x per 3 seconds
 - Both RCM – ON light active
 - Charging controller: green flashing light (1 x per 3 seconds)

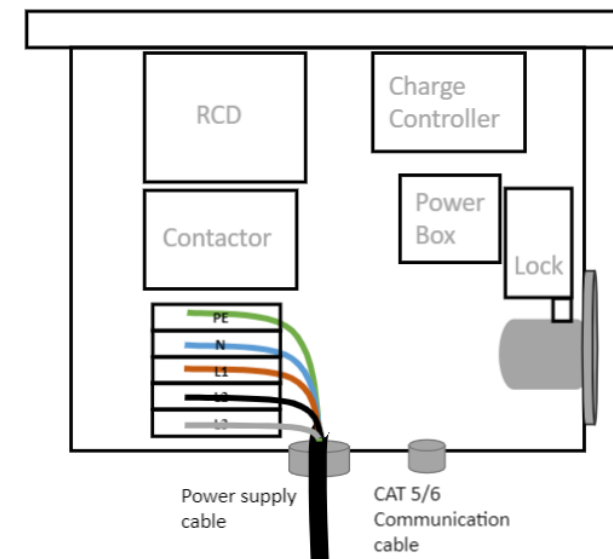
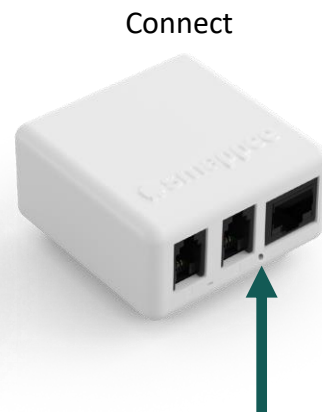
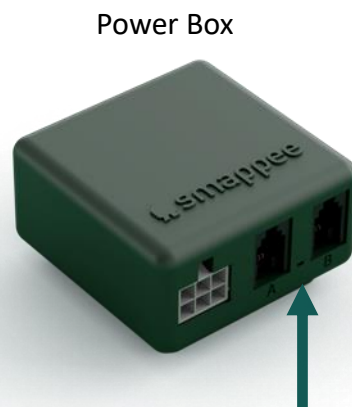

Step 2. Installation and activation

Download the Smappee Smappee Energy Monitor app (iOS or Android) on your mobile device.

Log in to the Smappee App with the corresponding Smappee username or create a new user account.



Step 2. Initial setup and configuration

Option 1: First Smappee installation.

Sign up to create a new account. Tap Install your first monitor and pick Smappee Infinity.

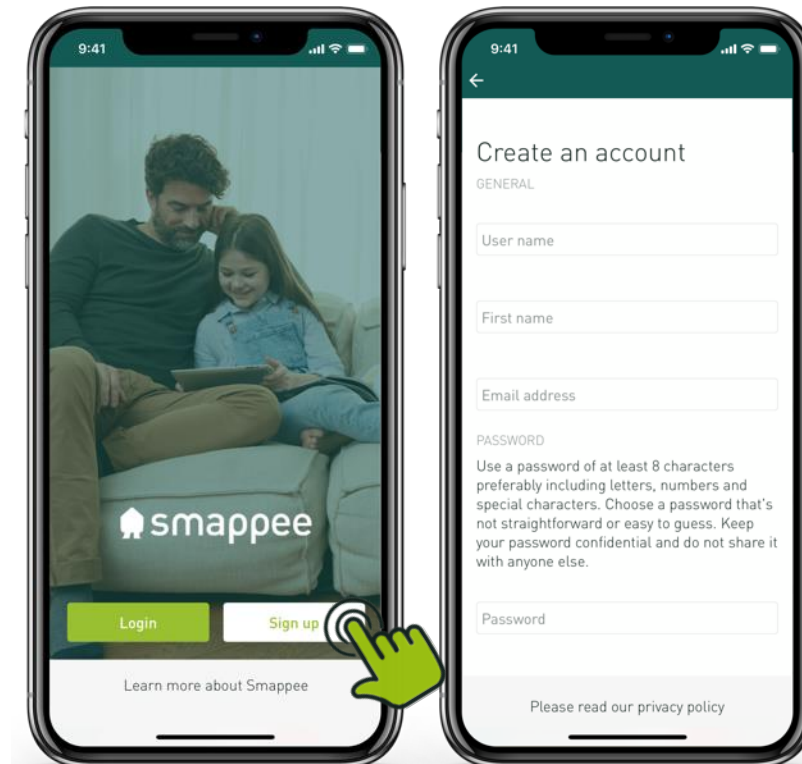

Step 2. Initial setup and configuration

Option 2: Add an additional installation on the same user account;
Log in the Smappee App, go to Settings > Your locations > add a new location and pick Smappee Infinity.

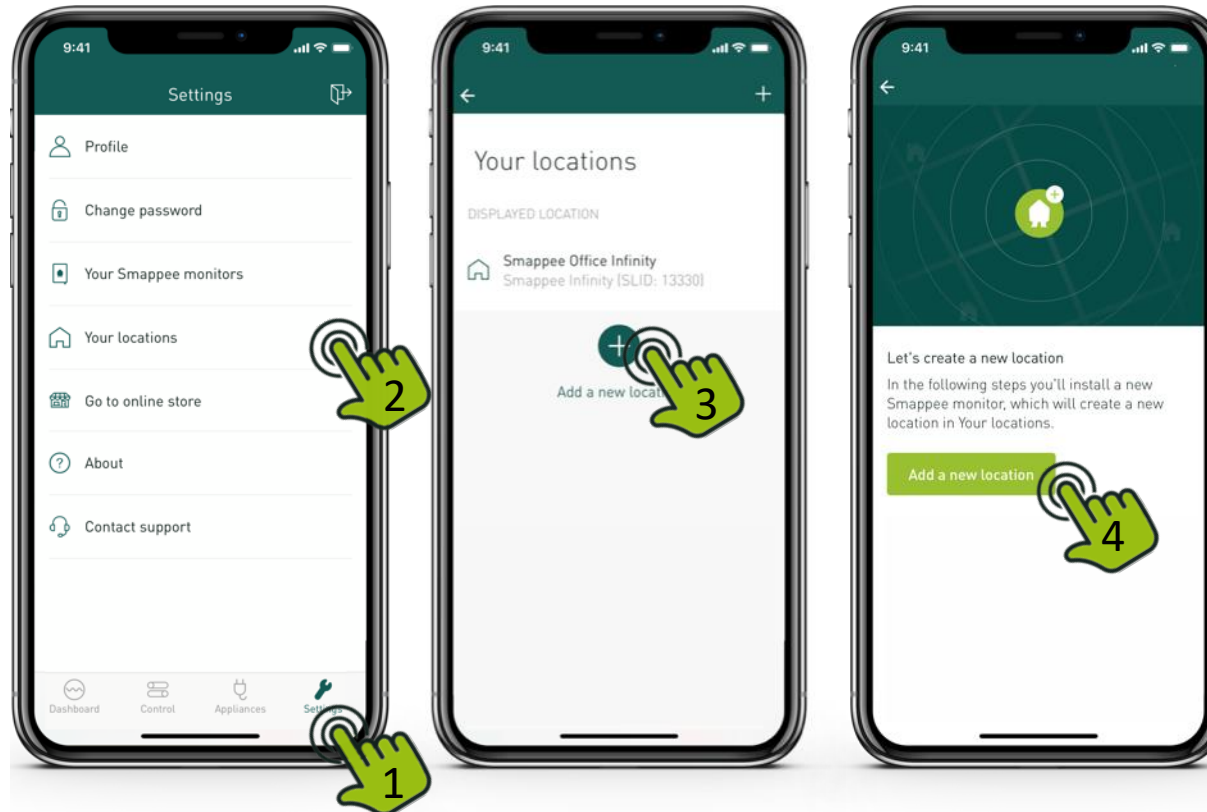

Step 2. Installation and activation

To install an EV Wall (Home), select 'I want to install a Smappee charging station':

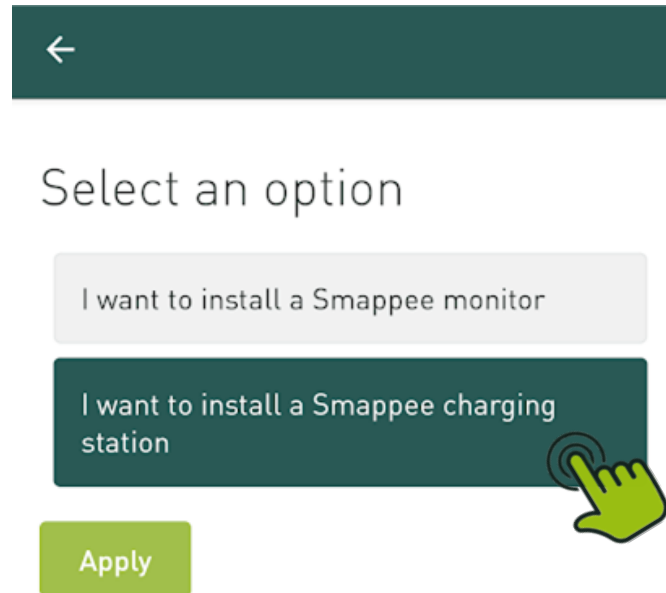

The screenshot shows a mobile application interface. At the top is a dark green header bar with a white left-pointing arrow. Below the header, the text "Select an option" is displayed. There are two selectable options: "I want to install a Smappee monitor" (light grey button) and "I want to install a Smappee charging station" (dark green button). A green hand icon with a white outline is pointing at the "I want to install a Smappee charging station" button. Below the options is a green "Apply" button.

Step 2. Installation and activation

Follow the steps shown in the mobile app.



S/N EV Line starts with 6xxxxxxxxx

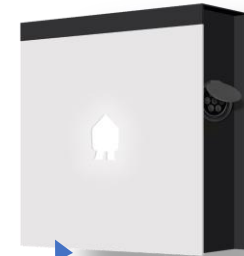

- 1  **smappee**
- 2 Art No: XXX-XXX-XXX-XXX
- 3 Rating: 32A-240/400V-50/60Hz. 1P/3P+N+PE
- 4  DD/MM/YYYY 5
- 5 IP 54 6
- 6 S/N: XXXXXXXXX 7
- 7  

Step 2. Installation and activation

Follow the steps shown in the mobile app.

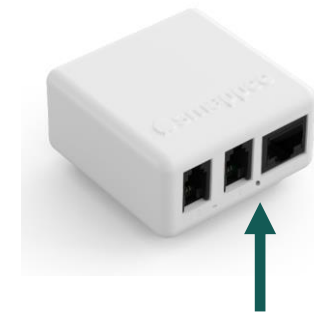
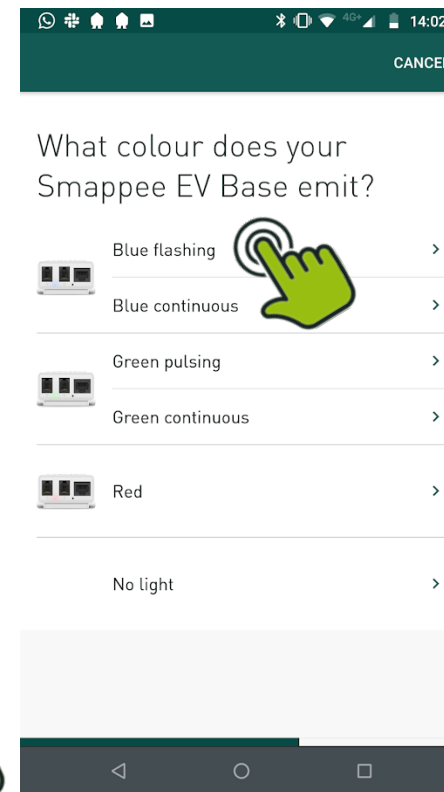
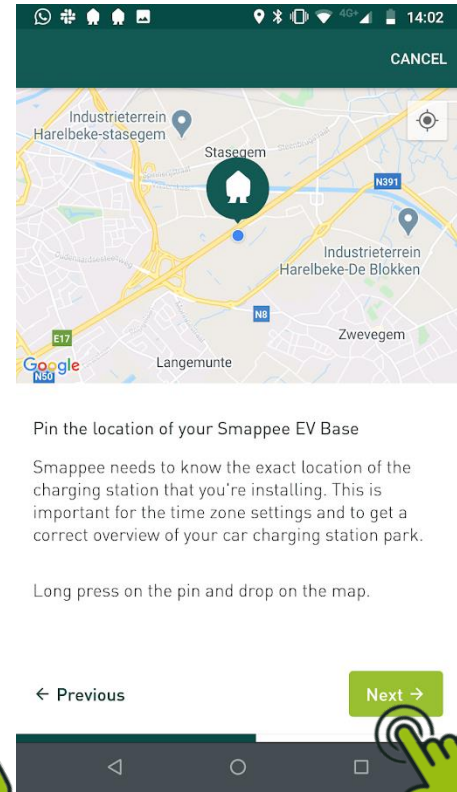
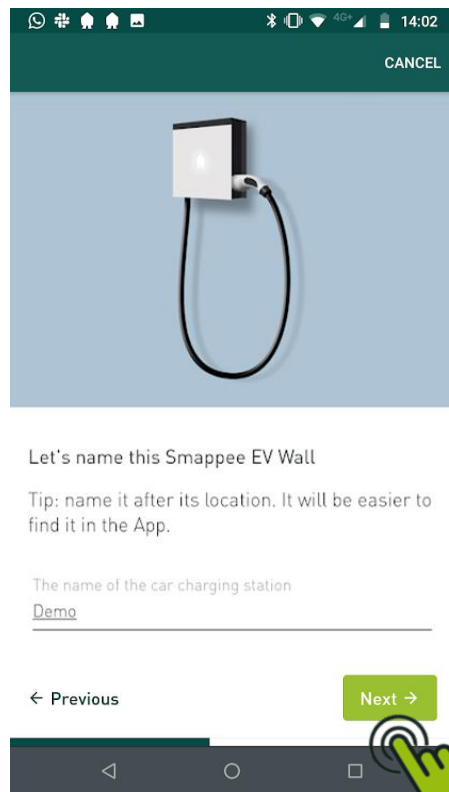

Step 2. Installation and activation

Follow the steps shown in the mobile app.

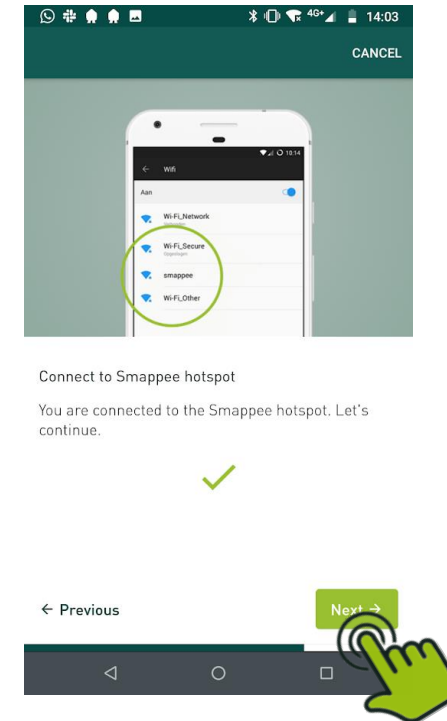
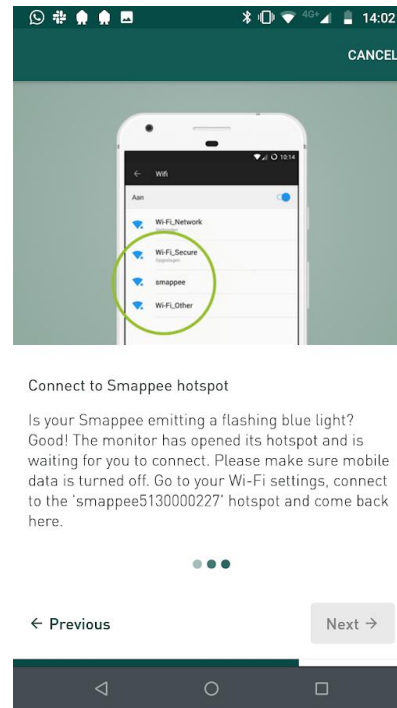
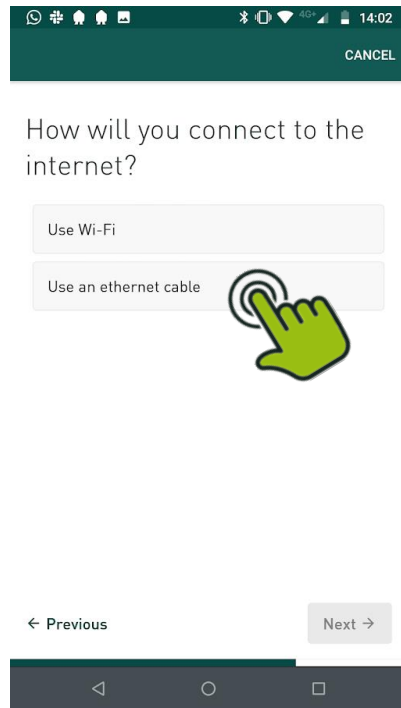

Step 2. Installation and activation

Follow the steps shown in the mobile app.

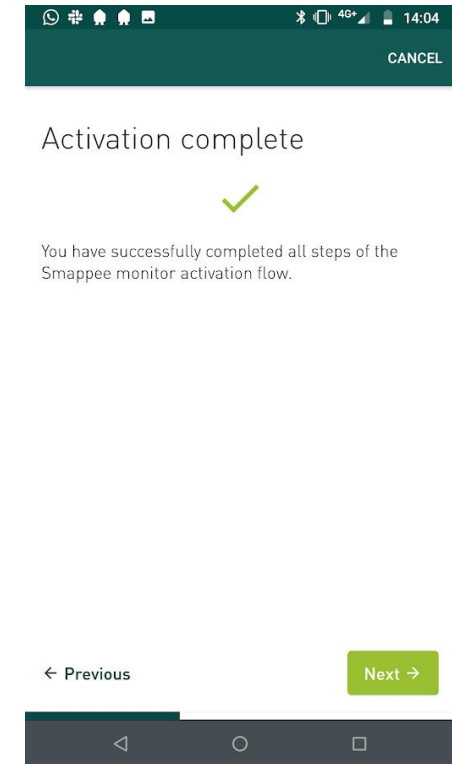
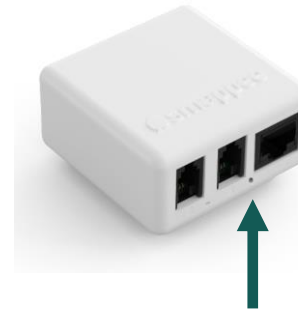
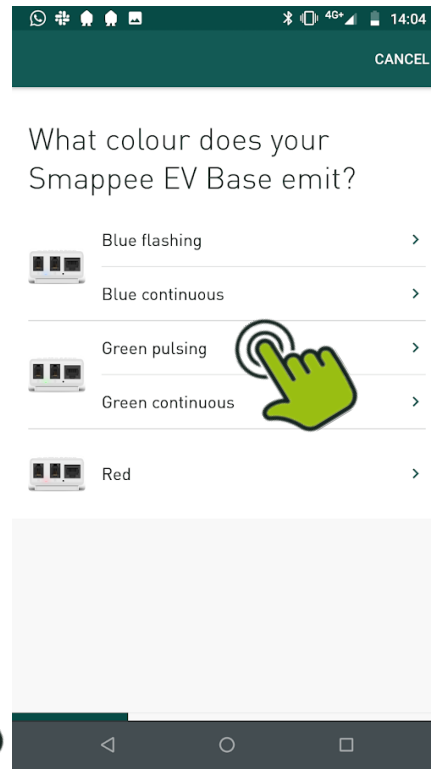
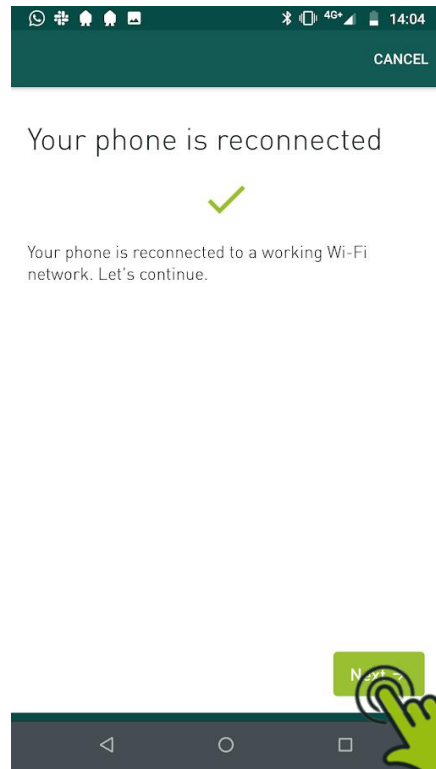

Step 2. Installation and activation

Follow the steps shown in the mobile app.

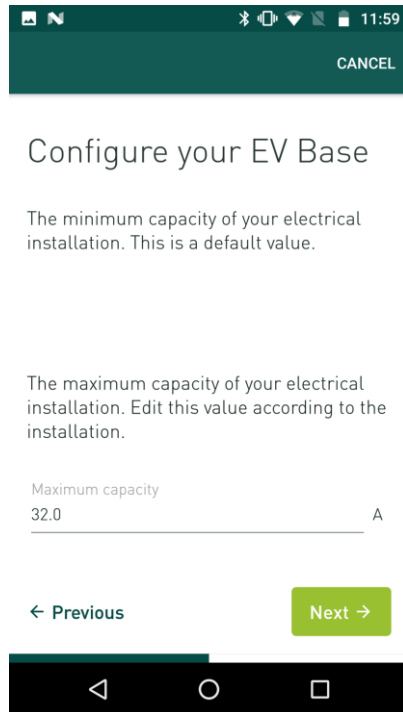

CANCEL

Configure your EV Base

The minimum capacity of your electrical installation. This is a default value.

The maximum capacity of your electrical installation. Edit this value according to the installation.

Maximum capacity
32.0 A

< Previous Next >

→ **Maximum:** the maximum current the charge point can provide



Settings are applicable to both connectors & can be changed later through App & Dashboard

Step 2. Installation and activation

Follow the steps shown in the mobile app.

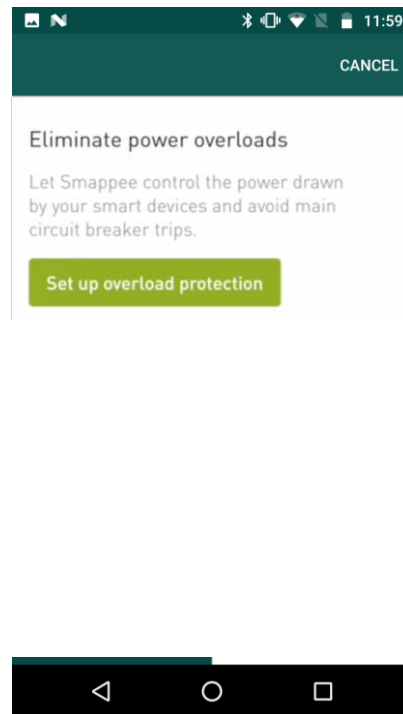

Overload protection: the maximum current of the main circuit breaker of the electrical installation

Step 3. Validation of the installation

Option 1: Smappee App

3. How to access the details of each measured load & CT.

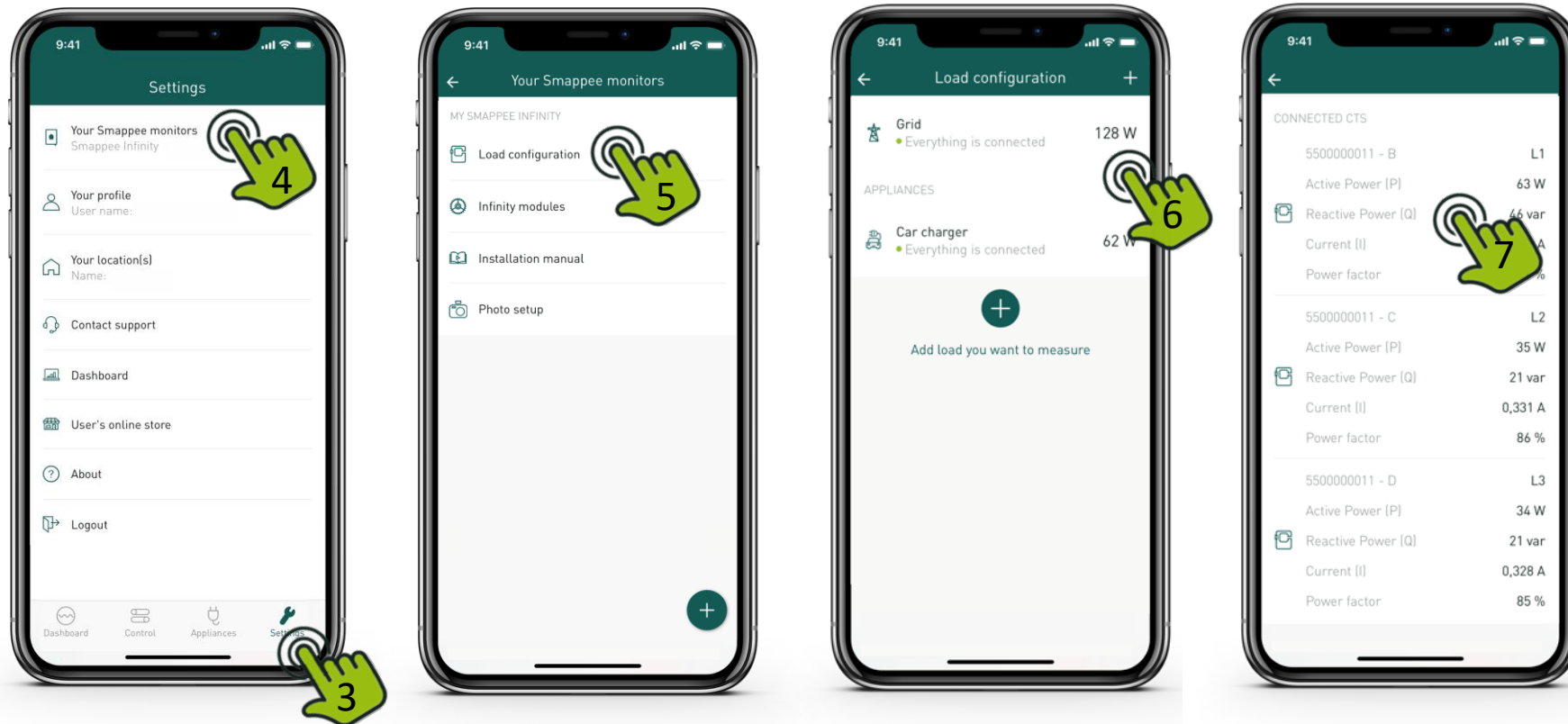

Step 3. Validation of the installation

- Is the current (A) correct?
- Is the Active power (P) value correct?
- In case of Production (solar):
 - The Power factor (PF) has to have a high value. It should be 90% or higher.
 - Is the production value correct?
 - **Grid values visualise actual values of the CT's. When solar is exported to the grid, these values will be negative.**

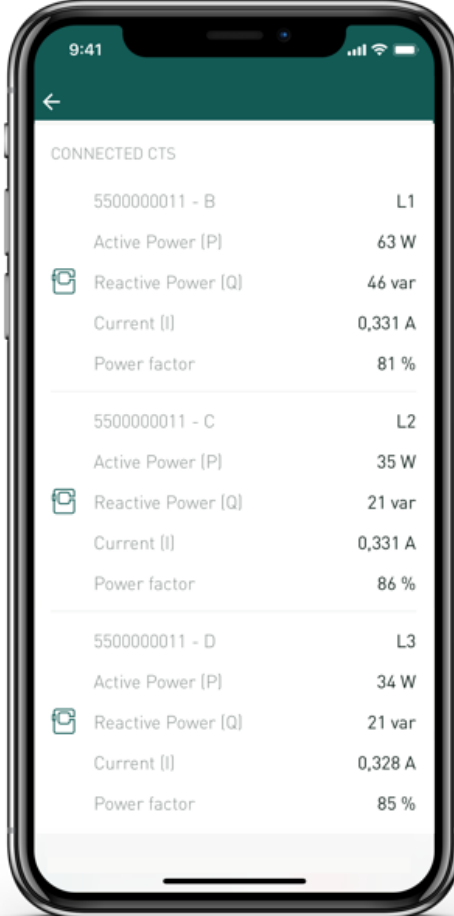

9:41

CONNECTED CTS

5500000011 - B	L1
Active Power (P)	63 W
Reactive Power (Q)	46 var
Current (I)	0,331 A
Power factor	81 %
5500000011 - C	L2
Active Power (P)	35 W
Reactive Power (Q)	21 var
Current (I)	0,331 A
Power factor	86 %
5500000011 - D	L3
Active Power (P)	34 W
Reactive Power (Q)	21 var
Current (I)	0,328 A
Power factor	85 %

Step 3. Validation of the installation

Option 1: Smappee App

3. How to access and change the details of each measured load & CT.

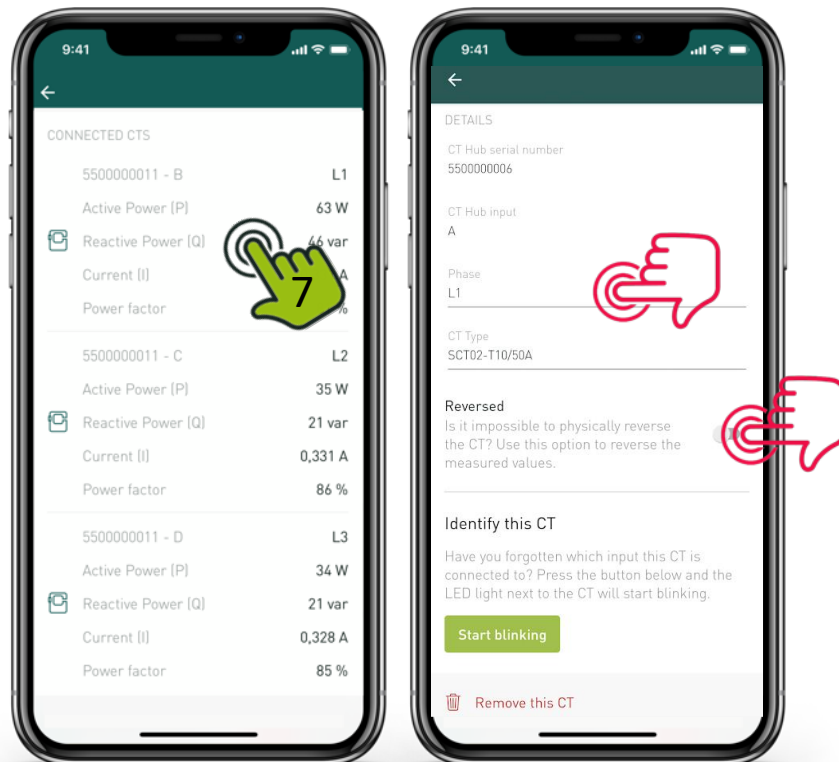

	Connect the CT to measure solar to the correct phase. Adjust the configuration in the Smappee App when this is not the L1 phase.
	When the solar installation is 3-phase, you need to purchase and install the EV Wall solar add-on.

Step 3. Validation of the installation

Overload or circuit breaker protection

Maximum current load setting is the setpoint of the Grid load:

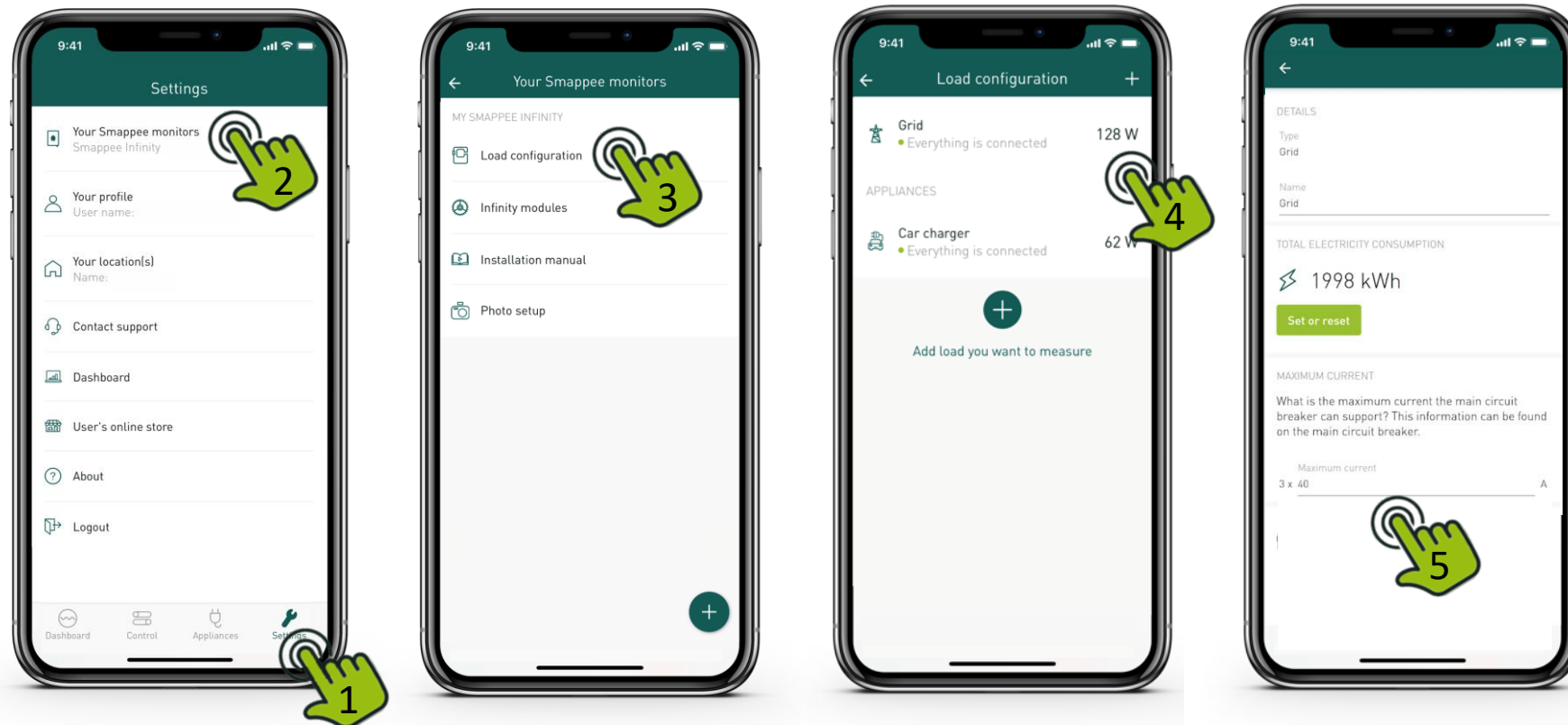

Step 3. Validation of the installation

Confirm the changes you've made to the load configuration. Tap "Apply changes" and save and activate the changes.

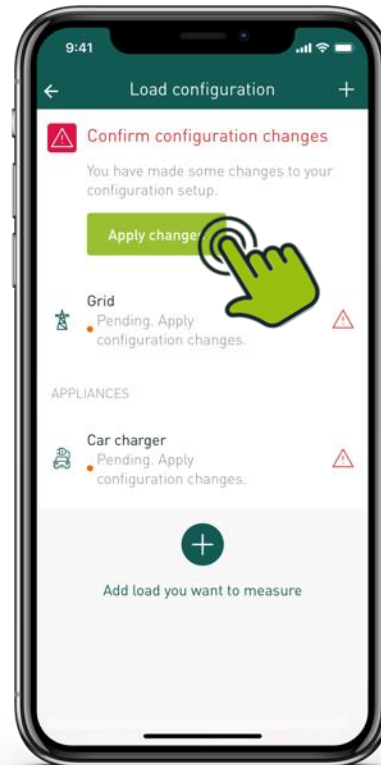

TIP: Changes to standard load configuration

Under Load configuration, changes to the pre-configured can be done and additional sub-metering can be added (e.g. additional solar panels,

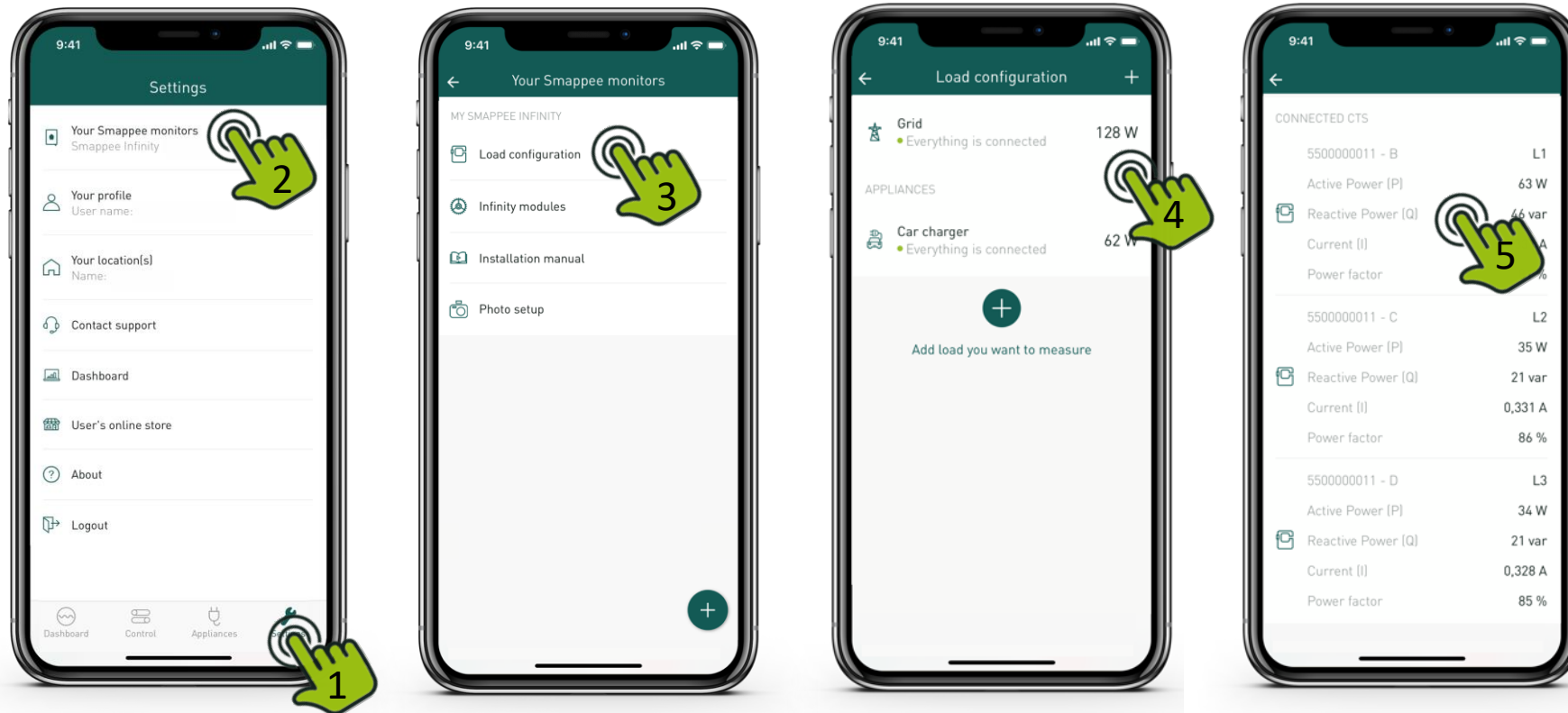

The car charger measurement cannot be adjusted or deleted.

Setup of LED Brightness

Setup of LED Brightness

LED Brightness

- The intensity of the white ambient lighting can be adjusted.

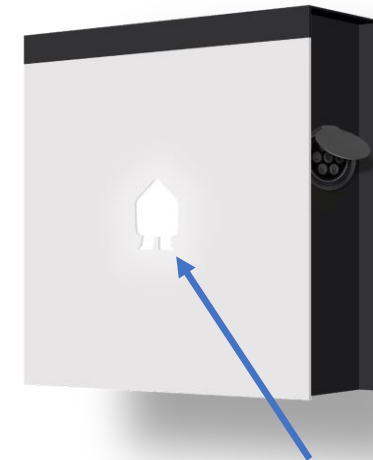
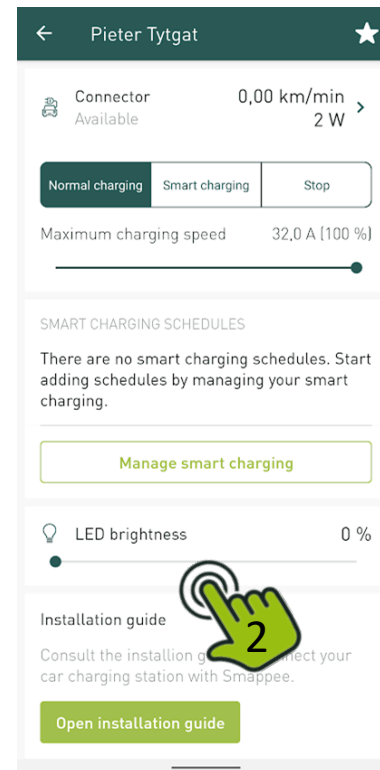
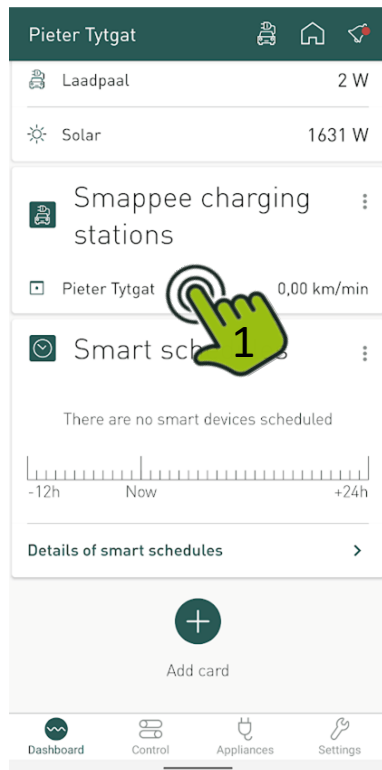

Dynamic Load Balancing

Setup of Dynamic Load Balancing

Overload or circuit breaker protection

Maximum current load setting is the setpoint of the Grid load:

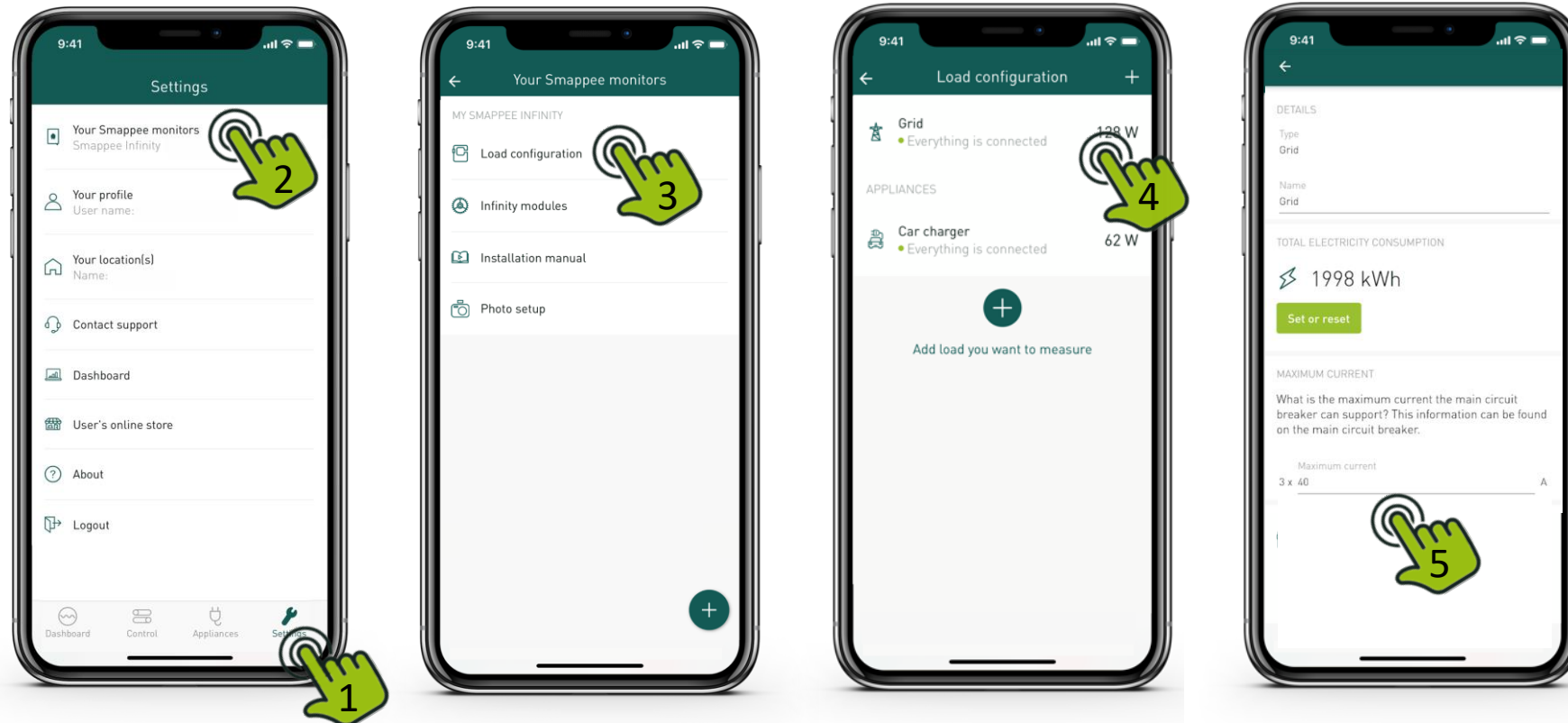

Setup of Dynamic Load Balancing

Solar & Cost Optimization:

- How: House owner sets smart charging schedules for each day of the week providing time of departure and required charged distance

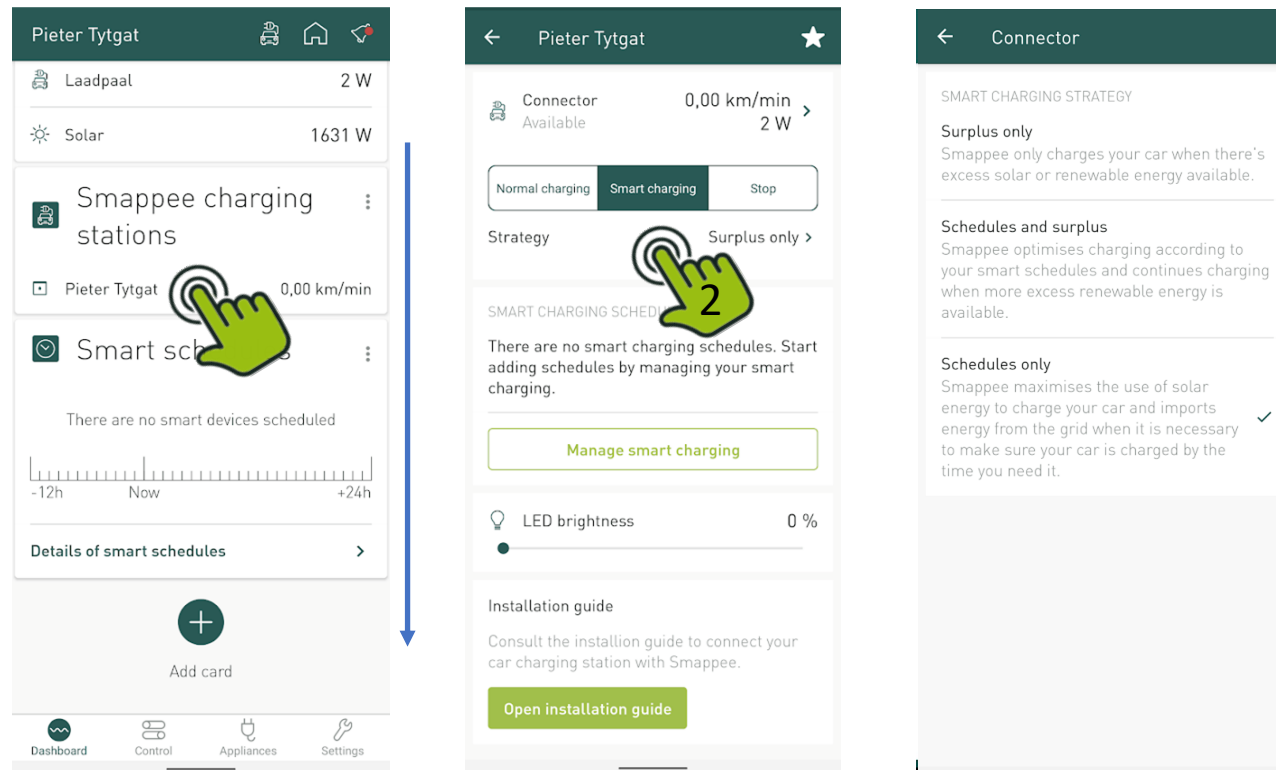

Setup of Dynamic Load Balancing

Solar & Cost Optimization:

- How: House owner sets smart charging schedules for each day of the week providing time of departure and required charged distance

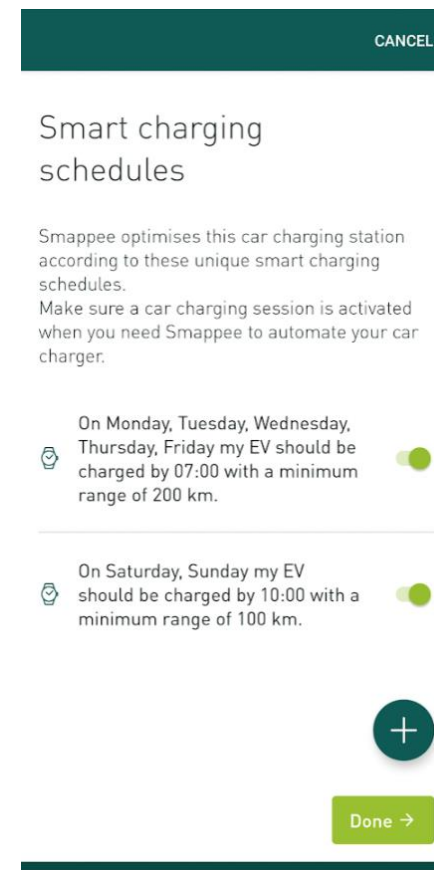
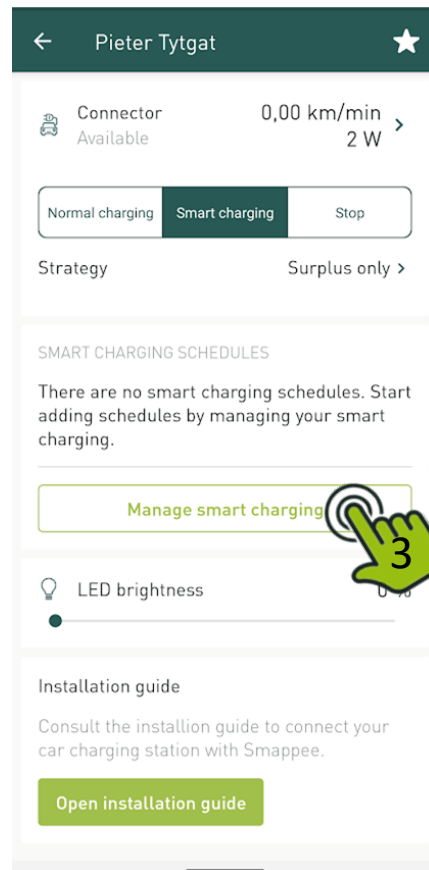

Setup of Dynamic Load Balancing

Cost Optimization:

- How: setup multi-tariffs to reduce cost on import of energy (if solar energy is not sufficient)

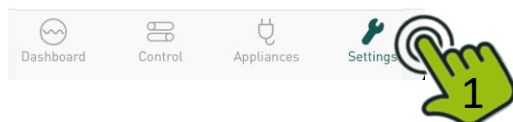
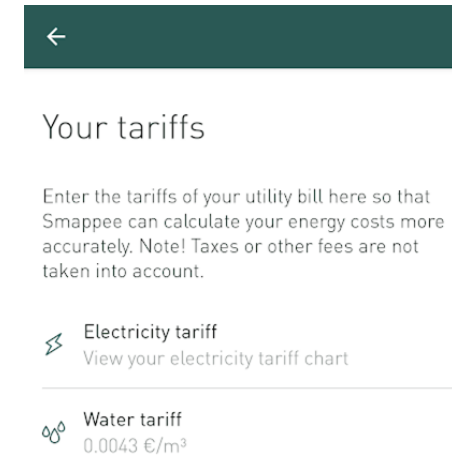
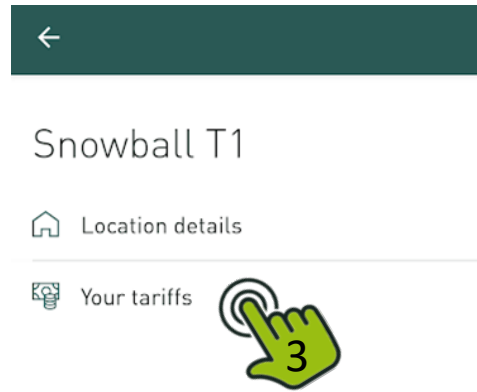
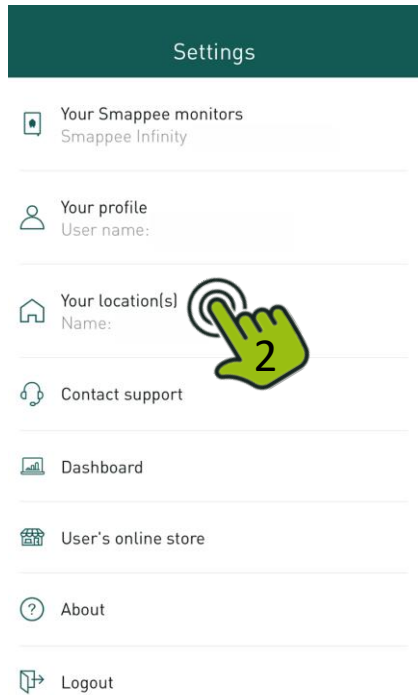

IMPORTANT notes
for 3P (3*230V) –
Delta

Step 2. Installation and activation

IMPORTANT notes for 3P (3*230V) – Delta

Power supply connection

- EV Line is connected as a 3-phase (3P) without isolation transformer.

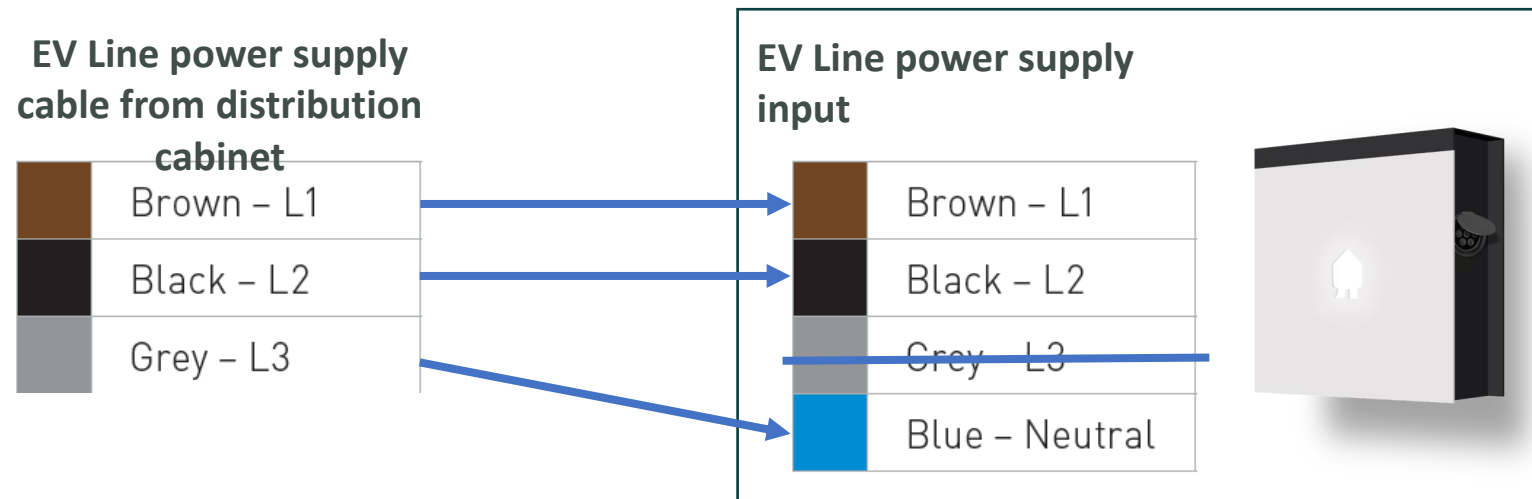

EV Wall – *Home*

IMPORTANT notes for 3P (3*230V) – Delta

- In case **an isolation transformer is used**, converting 3*230V (3P) to 3*400V (3P+N), **an additional Power Box needs to be purchased** and installed in the distribution panel.
- In the EV Wall (Home) unit, the RJ10 data cables on the in-built Power Box need to be disconnected.

EV Wall – Home

IMPORTANT notes for 3P (3*230V) – Delta

WITHOUT isolation transformer

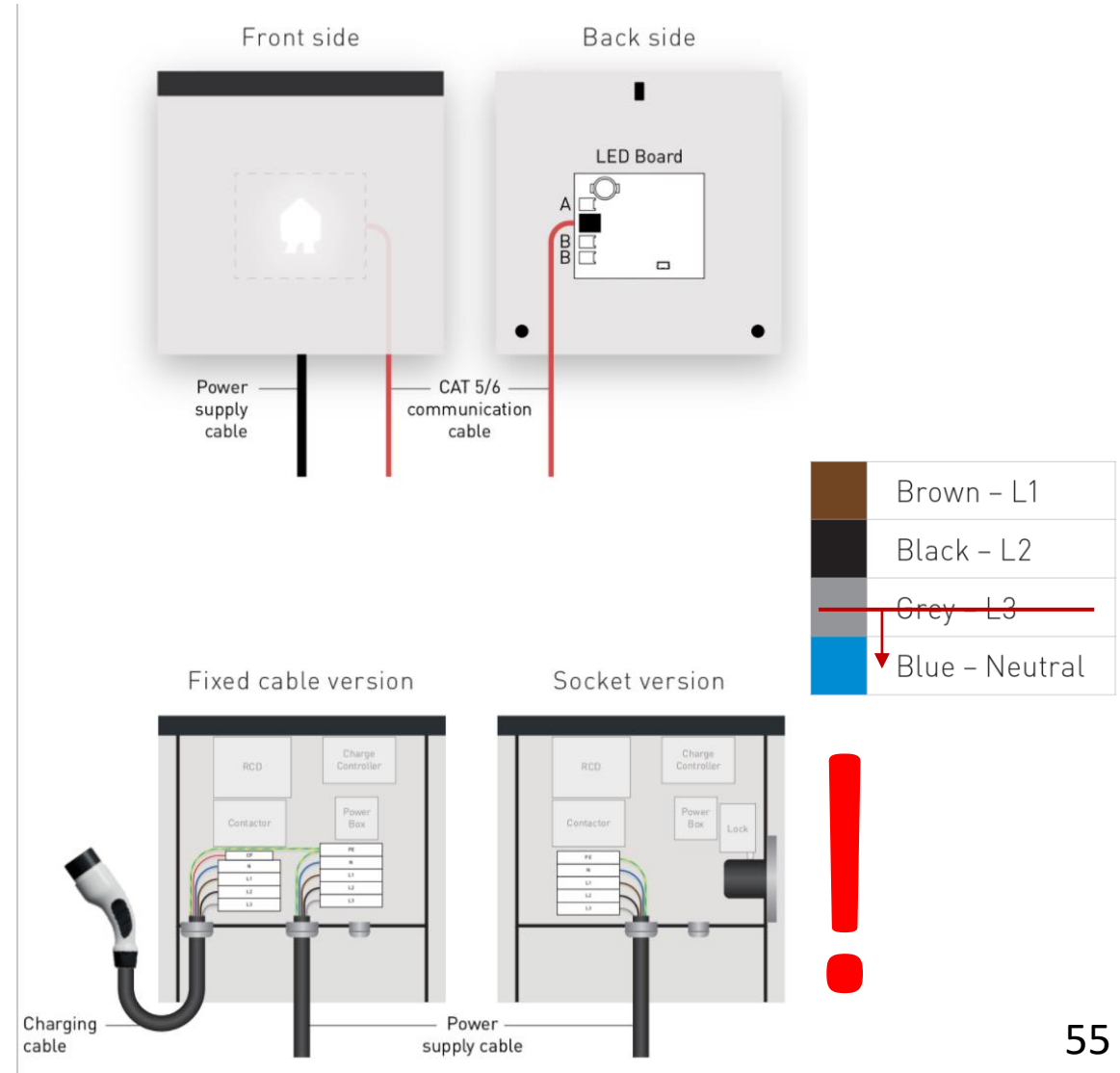
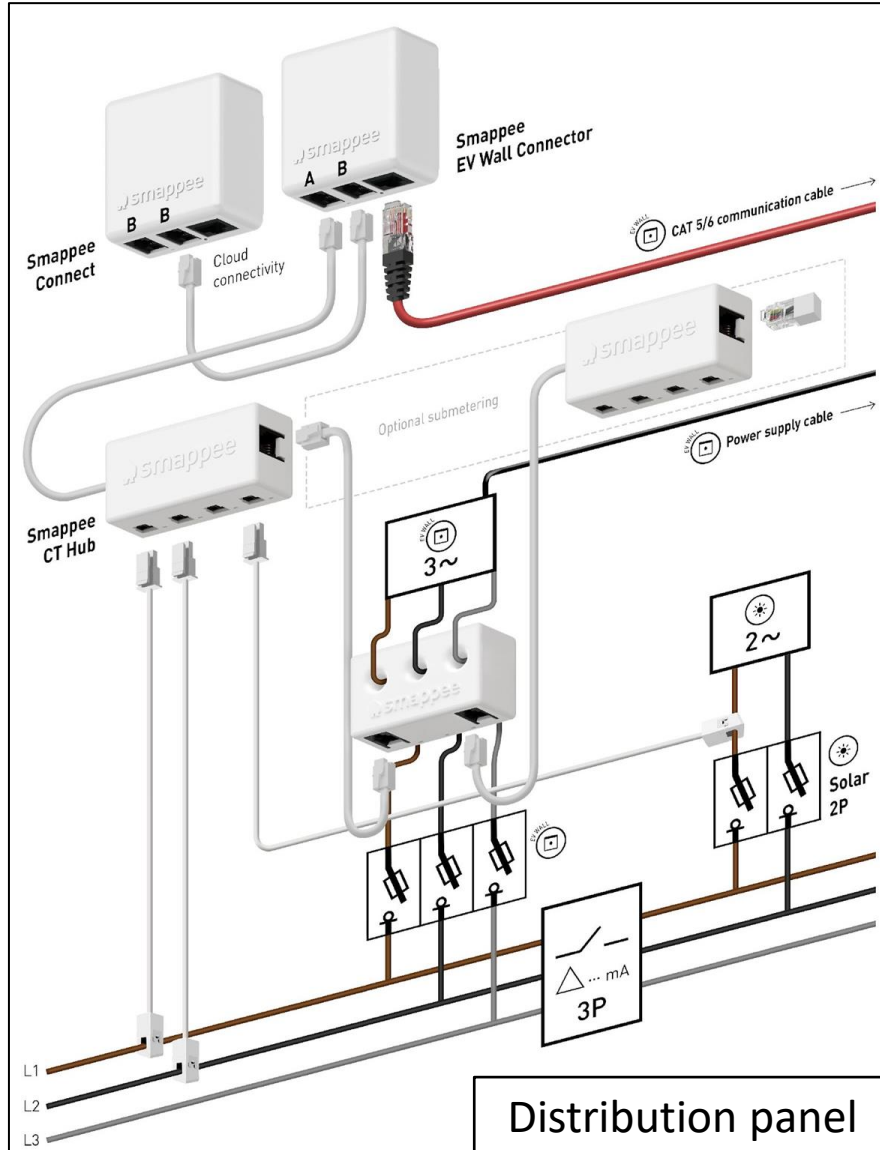

EV Wall – Home

IMPORTANT notes for 3P (3*230V) – Delta



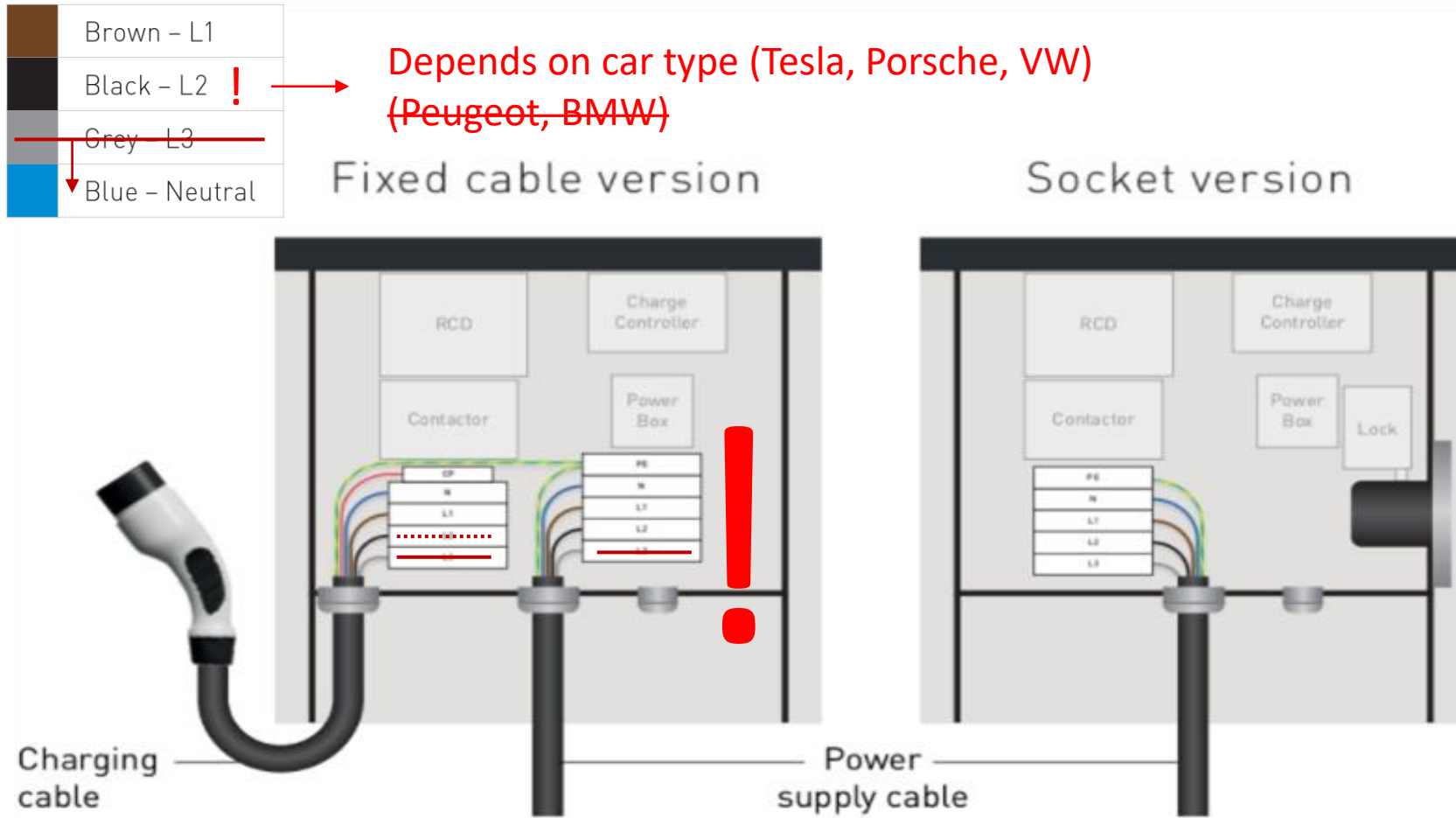

WITHOUT isolation transformer



3P (3*230V) – Delta

Important Notes:

- Grid always must be measured with L1 and L2.
- For 3-phase inverters, appliances or sub circuits always must be measured with clamps on L1 and L2.

	Brown - L1
	Black - L2
	Grey - L3
	Blue - Neutral

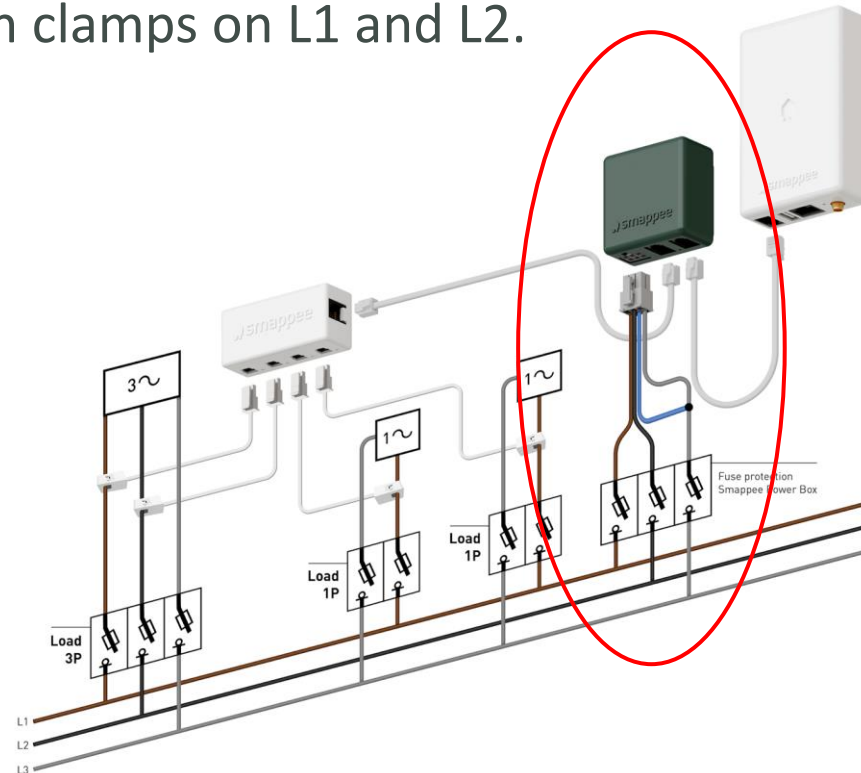

EV Wall – Home

IMPORTANT notes for 3P (3*230V) – Delta

In case an isolation transformer is used

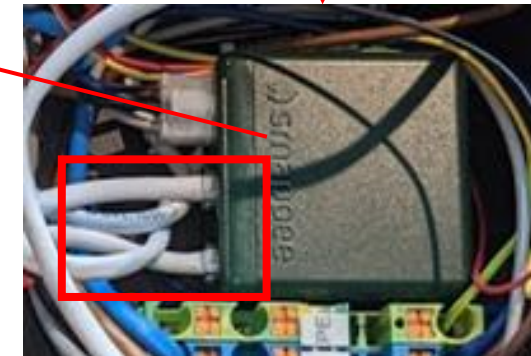
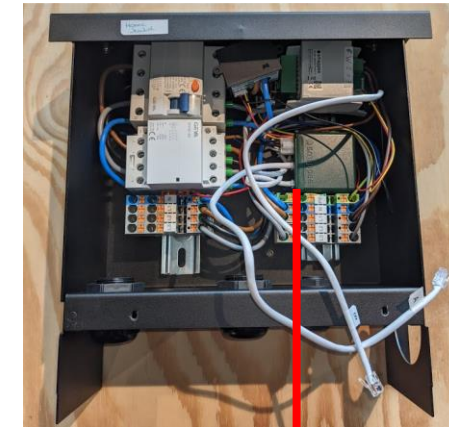
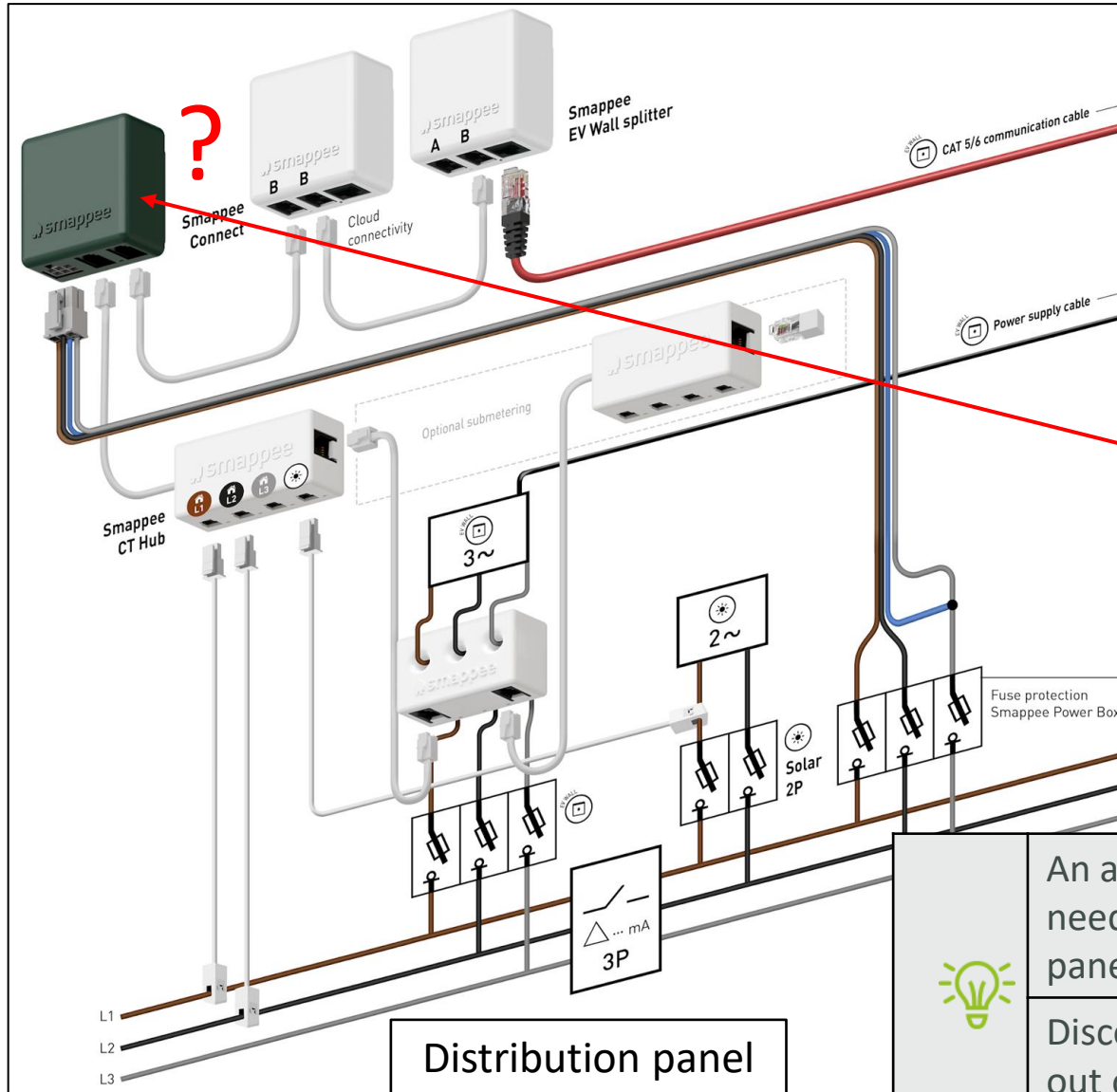

An additional Power Box (i1-VAC-1) needs to be installed in the distribution panel.

Disconnect both the RJ10 data cables out of the in-built Power Box

EV Wall – Home

IMPORTANT notes for 3P (3*230V) – Delta
In case an isolation transformer is used

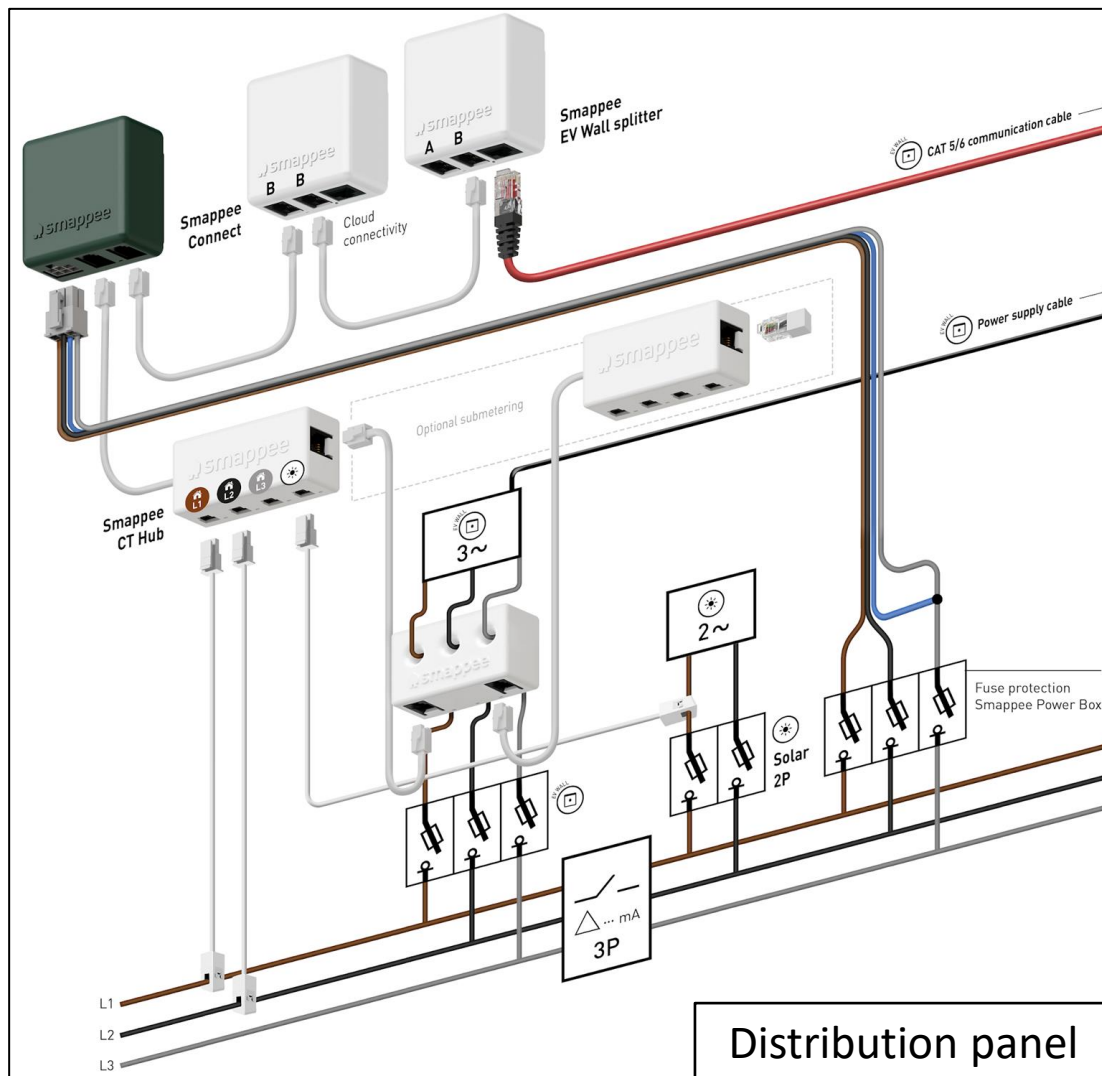

Charging station configuration Refresh Online

Property	Value
Location	Vandecasteele Noël
Name	Vancia Car Lease NV
Article code	EVW-AC1-CB-MID-RCM-RFID-ETH
Serial number	6101000003
Availability	Available Disable
Behind voltage transformer	<input checked="" type="checkbox"/>
LED brightness	100 %
Session activation method	Plug and charge
MAC address	98F4AB6044C4
Location ID	59309
Timezone	Europe/Brussels

17 properties

Items per page 20 << >> 59 Page 1 of 1

Setup of RFID-card authentication method

RFID-card authentication method



Swipe & Charge

Insert the connector, swipe your RFID card and start charging.

Steps:

1. Go to Dashboard <https://dashboard.smappee.net>
2. Login in with your App User Account
3. In 'Charging station configuration' card



Property	Value
Charging station configuration	Online
Location	Snowball T1
Name	Charging Station 8
Article code	EVB-AC2-CC-MID-RCM-RFID-ETH
Serial number	6000000008
Availability	Available <input type="button" value="Disable"/>
LED brightness	100 %
Session activation method	Plug & Charge
MAC address	98F4AB66F794









4. Session Activation Method



4. Activate Swipe & Charge – Setup & Free charging
5. Add RFID Tokens (barcode) to be added through ‘Whitelisting’ card:

Whitelisting at Snowball T1   + Add token 

Token	Identification	Priority [%]	Expiration date	Actions
0413D262756880	Stefan	100	N/A	 
0436D262756880	Pieter	100	N/A	 
0453CA62756881	Alexandra	100	N/A	 

Session activation method of 'Charging Station 8' ×

Session activation method

Plug & Charge cannot be combined with 'Scan & Charge' or 'Swipe & Charge'.

Plug & Charge

Plug the charging cable in your car and your free charging session starts automatically.

Scan & Charge (QR code)

Plug the charging cable in the car. Scan the QR code with the Smappee app. Your charging session starts automatically. Pay when your charging session has ended.

Swipe & Charge (RFID tag)

First plug the charging cable in your car. Swipe your card on the RFID reader of the charging station. Your charging session starts automatically.

Free charging

Charging is free with your Smappee Smart Charge Card or any other authorized RFID card. All authorized cards must first be added to the whitelist using the 'Whitelisting' card in the dashboard.

Public charging

Other EV drivers can use this charging station and pay with their third party eMSP card.

Smappee CSMS

Other CSMS

Charging Station Management System host url

 Save settings

Wrap-Up on-site installation

Sharing Smappee location with end customer

Transfer location to end user

Installer – End user

After completing the installation procedure, the location needs to be transferred to the end user (location owner).

1. Ask the end user to install the Smappee Energy Monitor app (iOS or Android) on his mobile device.
2. Let the end user sign up for a new user name on his own mobile device

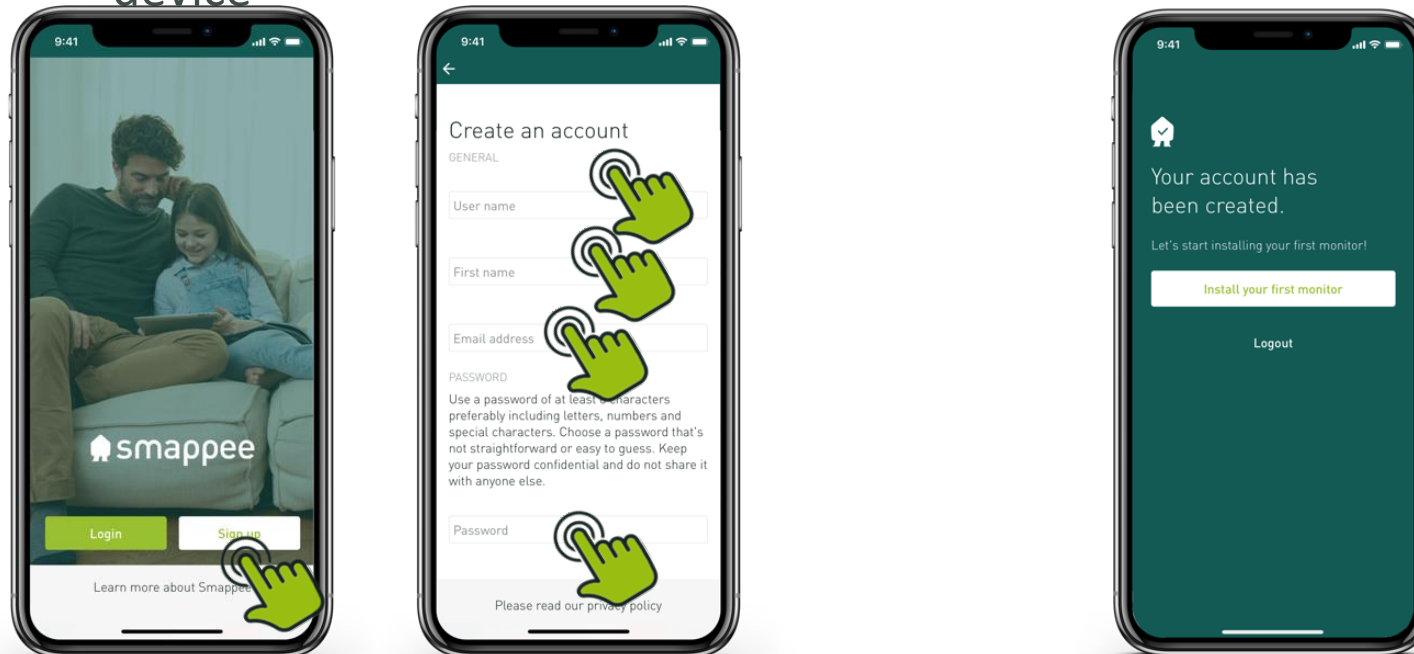

Transfer location to end user

Installer – End user

3. The installer shares the location with the end user:

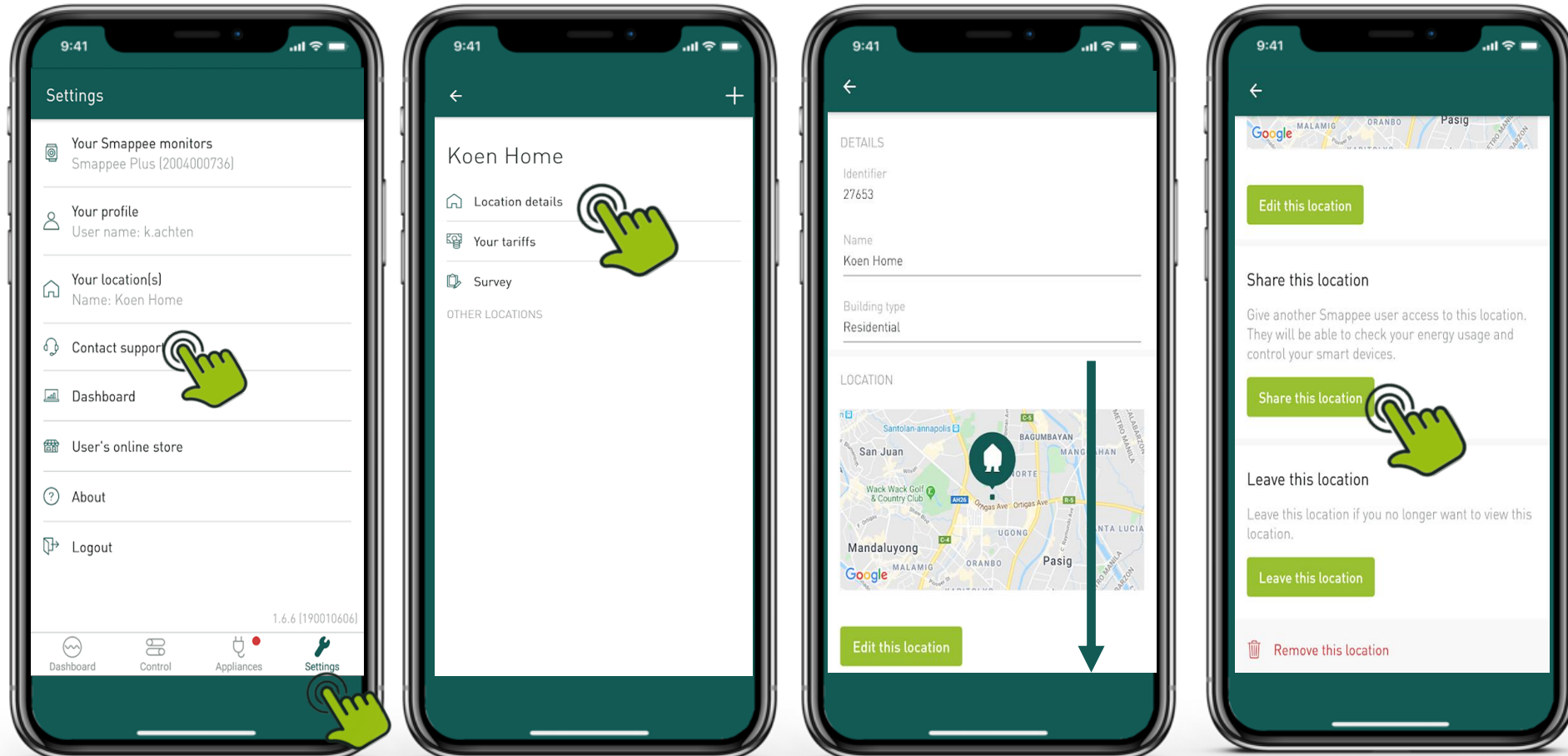

Transfer location to end user

Installer – End user

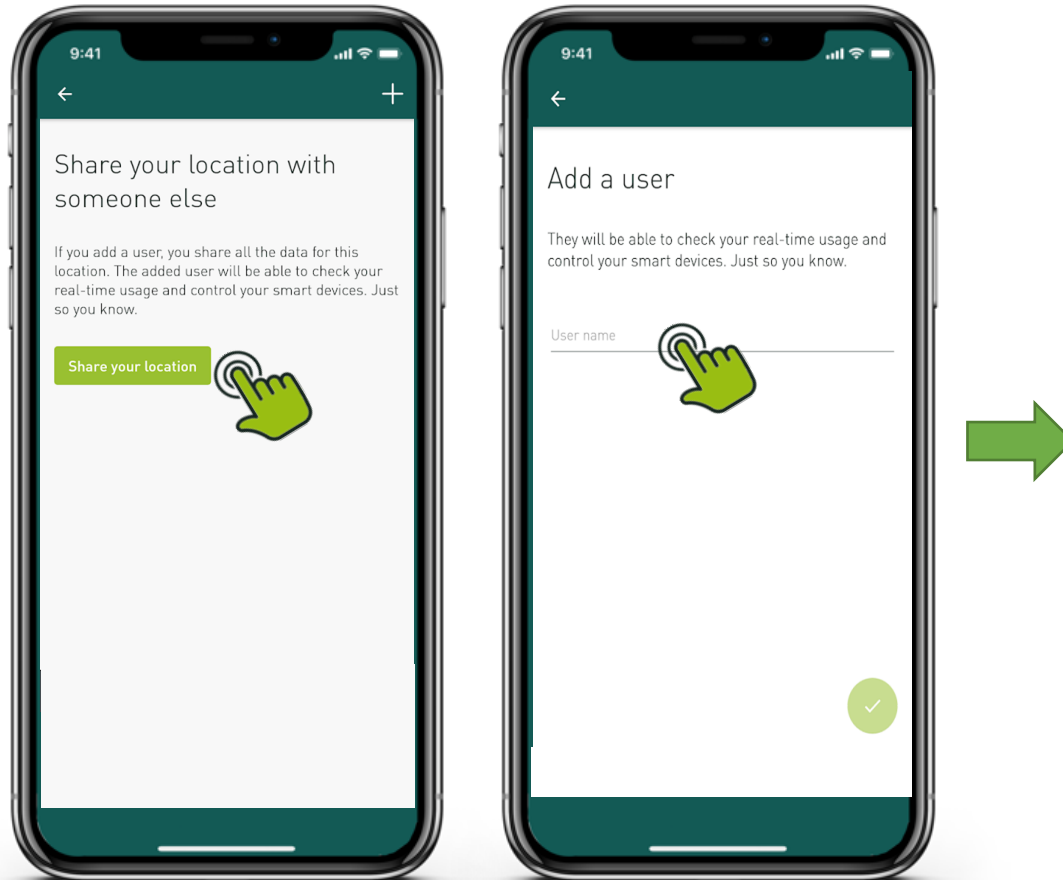

On the end user phone:

- Close the Smappee app and reopen. The location is now available in the app.
- Alternative: Logout from the Smappee app and login again

Fill in the Smappee user name
to share the location with

Smappee Dashboard

Advanced settings for EV Wall (residential)

Smappee Dashboard

- Visualize real-time and historical data for each charging point or hubs, together with Energy Monitor data
- Data across multiple sites in one place
- Get an overview of charging consumption and costs
- Manage charging points & hubs
 - Visualize live status
 - Adjust charge point and connector settings
 - Mark charge point as unavailable
 - Priority charging & multiple rates (discounts)
- Data export (MS Excel, csv)

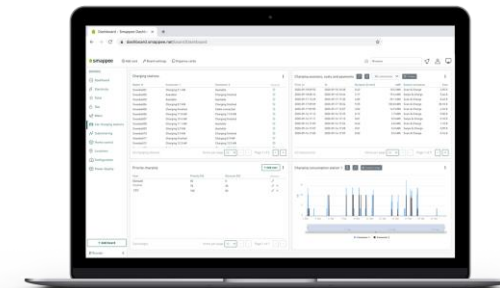
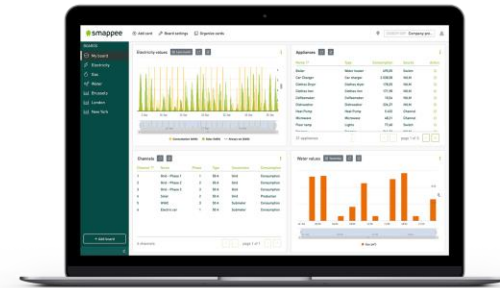

[Link: https://dashboard.smappee.net](https://dashboard.smappee.net)



The Smappee Dashboard has a preset layout.
Additional boards and cards can be added by the user.

Smappee Dashboard

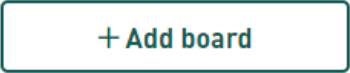
- Log in with Smappee user: Basic or Partner user
- Add a new board – 
- Use the 'Charging Management template', adds all EV-related cards in the Dashboard

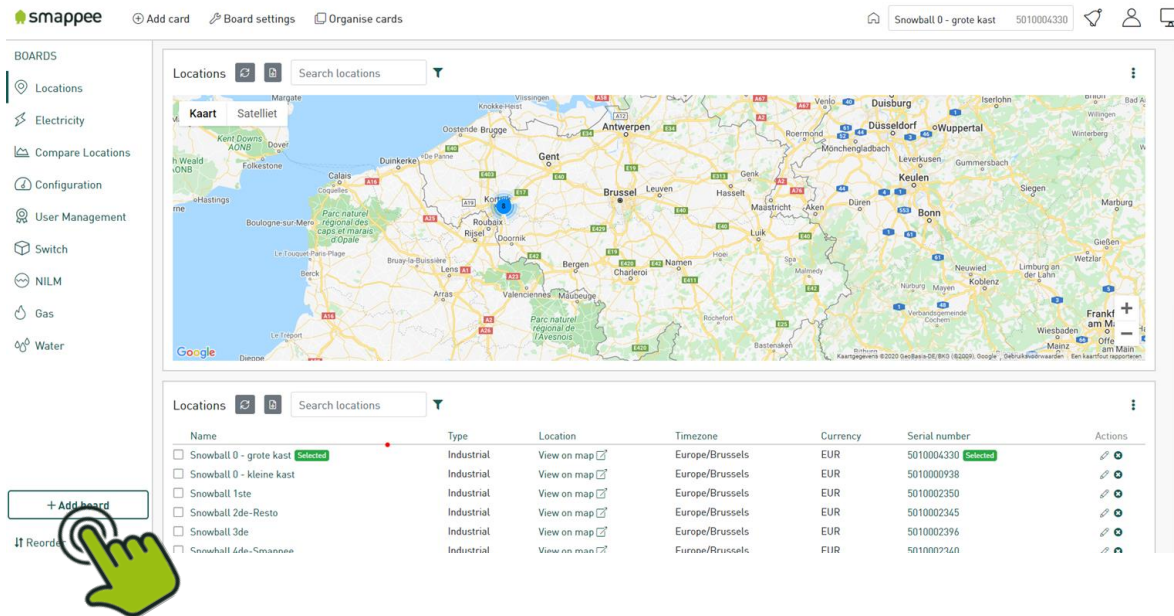

The screenshot shows the Smappee dashboard interface. On the left is a sidebar with navigation options: Locations, Electricity, Compare Locations, Configuration, User Management, Switch, NILM, Gas, and Water. The main area is divided into two sections. The top section is a map titled 'Locations' with a search bar and a 'Kart' button. The bottom section is a table of locations with columns for Name, Type, Location, Timezone, Currency, Serial number, and Actions. A green hand icon points to the '+ Add board' button in the bottom left corner of the table area.

Name	Type	Location	Timezone	Currency	Serial number	Actions
<input type="checkbox"/> Snowball 0 - grote kast Selected	Industrial	View on map	Europe/Brussels	EUR	5010004330 Selected	Edit Delete
<input type="checkbox"/> Snowball 0 - kleine kast	Industrial	View on map	Europe/Brussels	EUR	5010000938	Edit Delete
<input type="checkbox"/> Snowball 1ste	Industrial	View on map	Europe/Brussels	EUR	5010002350	Edit Delete
<input type="checkbox"/> Snowball 2de-Resto	Industrial	View on map	Europe/Brussels	EUR	5010002345	Edit Delete
<input type="checkbox"/> Snowball 3de	Industrial	View on map	Europe/Brussels	EUR	5010002396	Edit Delete
<input type="checkbox"/> Snowball 4de-Smannen	Industrial	View on map	Europe/Brussels	EUR	5010002345	Edit Delete

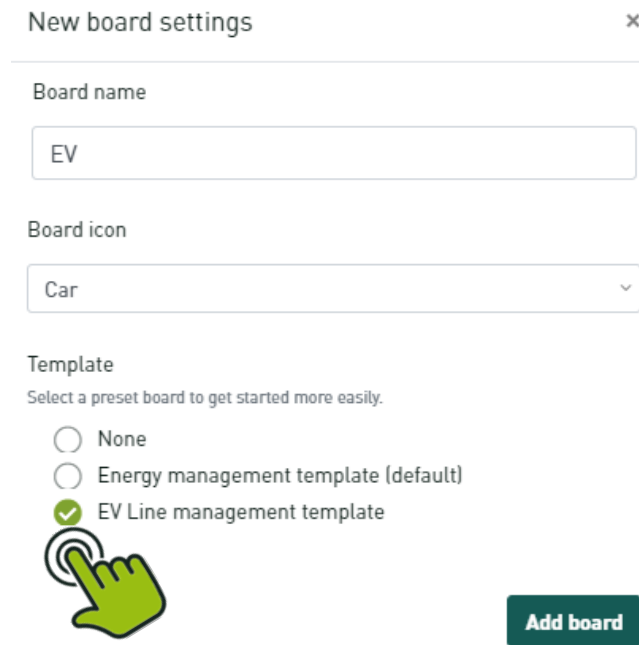

The screenshot shows the 'New board settings' dialog box. It has a close button (X) in the top right corner. The form contains the following fields:

- Board name:
- Board icon:
- Template:

Select a preset board to get started more easily.

 - None
 - Energy management template (default)
 - EV Line management template

A green hand icon points to the 'EV Line management template' radio button. At the bottom right is a dark green 'Add board' button.

Smappee Dashboard

- Log in with Smappee user: Basic (App) or Partner user
- Navigate to Smappee location (EV Wall – Home), using serial number or location name.

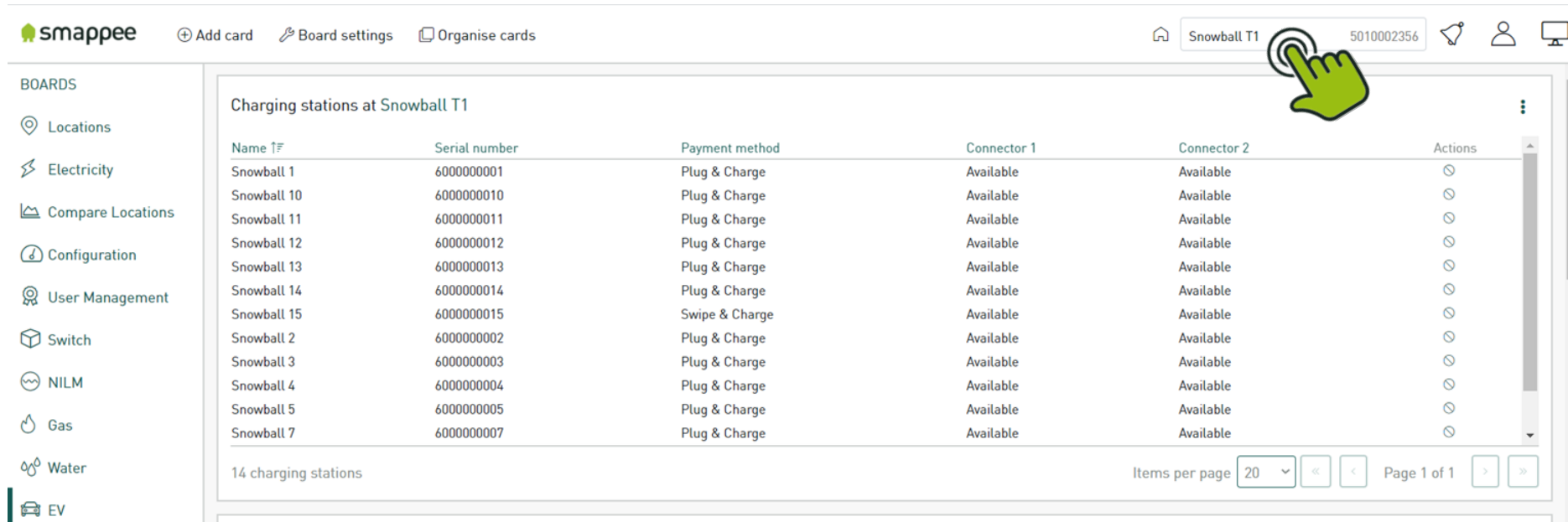

The screenshot displays the Smappee dashboard interface. At the top, there is a navigation bar with the Smappee logo, 'Add card', 'Board settings', and 'Organise cards' options. On the right side of the top bar, there is a search bar containing 'Snowball T1' and the serial number '5010002356', along with icons for home, notifications, user profile, and a monitor. A green hand icon with a red circle highlights the search bar.

The main content area is titled 'Charging stations at Snowball T1' and contains a table with the following data:

Name ↑	Serial number	Payment method	Connector 1	Connector 2	Actions
Snowball 1	6000000001	Plug & Charge	Available	Available	⊙
Snowball 10	6000000010	Plug & Charge	Available	Available	⊙
Snowball 11	6000000011	Plug & Charge	Available	Available	⊙
Snowball 12	6000000012	Plug & Charge	Available	Available	⊙
Snowball 13	6000000013	Plug & Charge	Available	Available	⊙
Snowball 14	6000000014	Plug & Charge	Available	Available	⊙
Snowball 15	6000000015	Swipe & Charge	Available	Available	⊙
Snowball 2	6000000002	Plug & Charge	Available	Available	⊙
Snowball 3	6000000003	Plug & Charge	Available	Available	⊙
Snowball 4	6000000004	Plug & Charge	Available	Available	⊙
Snowball 5	6000000005	Plug & Charge	Available	Available	⊙
Snowball 7	6000000007	Plug & Charge	Available	Available	⊙

At the bottom of the table, it indicates '14 charging stations'. Below the table, there is a pagination control showing 'Items per page' set to 20, and 'Page 1 of 1'.

Smappee Dashboard



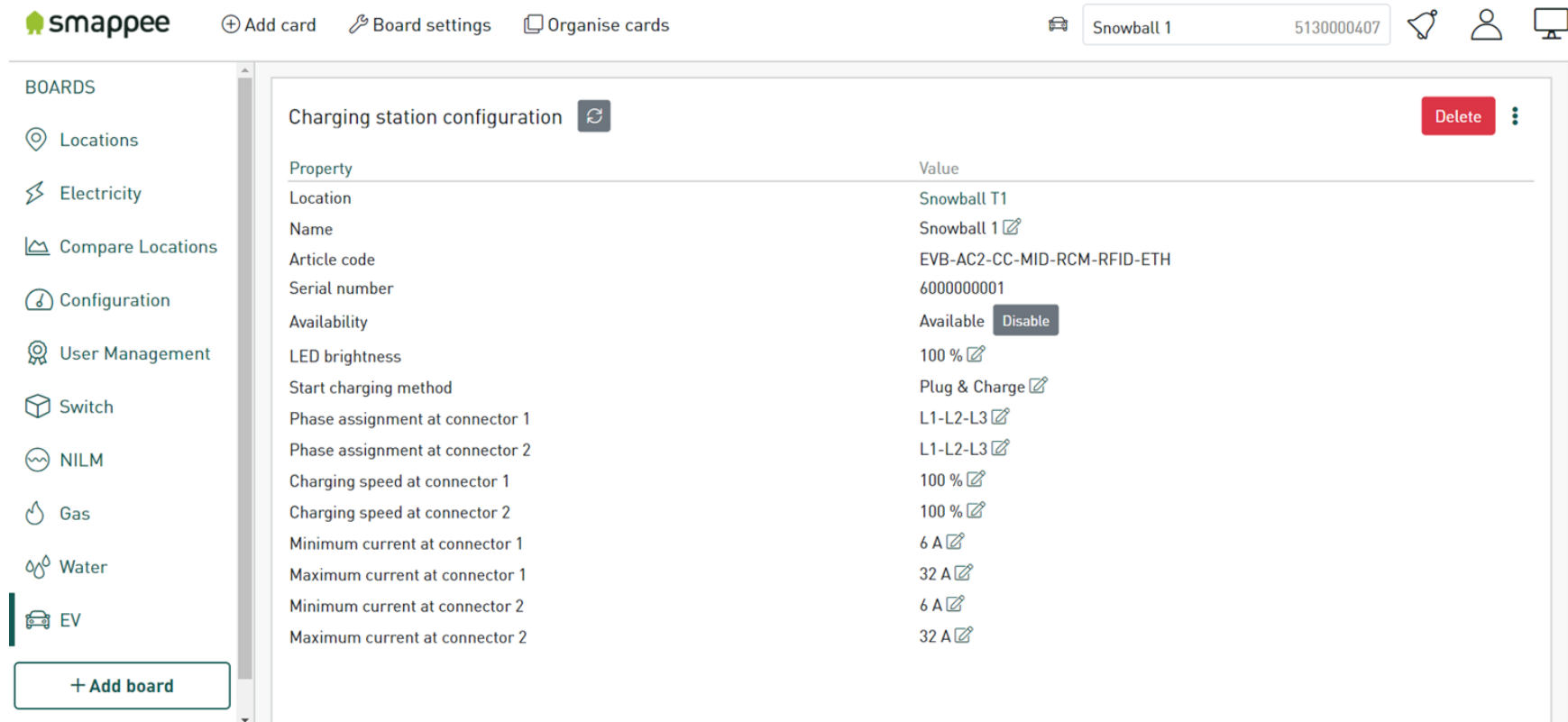







- Charging station configuration card displays all settings of the EV Line
- To edit settings, press  icon under 'Value' column



The screenshot shows the Smappee dashboard interface. At the top, there is a navigation bar with the Smappee logo, 'Add card', 'Board settings', and 'Organise cards' buttons. On the right, there are icons for a car, a search bar containing 'Snowball 1' and '5130000407', a notification bell, a user profile, and a monitor icon.

The main content area is titled 'BOARDS' and contains a list of categories: Locations, Electricity, Compare Locations, Configuration, User Management, Switch, NILM, Gas, Water, and EV. The 'EV' category is selected, and a '+ Add board' button is visible at the bottom.

The 'Charging station configuration' card is displayed, showing a table of properties and values. The table has two columns: 'Property' and 'Value'. The 'Value' column includes edit icons for most entries. The 'Availability' property has a 'Disable' button instead of an edit icon.

Property	Value
Location	Snowball T1
Name	Snowball 1 
Article code	EVB-AC2-CC-MID-RCM-RFID-ETH
Serial number	6000000001
Availability	Available <input type="button" value="Disable"/>
LED brightness	100 % 
Start charging method	Plug & Charge 
Phase assignment at connector 1	L1-L2-L3 
Phase assignment at connector 2	L1-L2-L3 
Charging speed at connector 1	100 % 
Charging speed at connector 2	100 % 
Minimum current at connector 1	6 A 
Maximum current at connector 1	32 A 
Minimum current at connector 2	6 A 
Maximum current at connector 2	32 A 

Smappee Dashboard





Session Activation Method setup

How to activate the supplied Smappee RFID card for authentication:



2. Navigate to the Whitelisting'-card:

- Click on '+ Add token'
- fill in the RFID number mentioned on the back side of the Smappee RFID card

Token	Identification	Priority [%]	Expiration date	Actions
0413D262756880	Stefan	100	N/A	 

Differences with Business variants

Smappee EV Line

Home	Business	
 <p data-bbox="675 486 930 521">Smappee EV Wall</p> <ul data-bbox="479 782 853 888" style="list-style-type: none">• Energy and charging data• Overload protection• Solar optimisation <p data-bbox="479 935 930 1002">Infinity & Smart Charging Package included!</p> <p data-bbox="479 1168 1014 1235">Internet connectivity at the distribution panel</p> <ul data-bbox="479 1245 789 1310" style="list-style-type: none">• Ethernet (preferred)• 2.4 GHz Wi-Fi	 <p data-bbox="1235 486 1490 559">Smappee EV Wall Business</p> <ul data-bbox="1057 782 1286 853" style="list-style-type: none">• Charging data• MID metering <p data-bbox="1057 896 1508 968">Infinity & Smart Charging Package need to be purchased separately:</p> <ul data-bbox="1057 973 1477 1116" style="list-style-type: none">• Energy data• Overload protection• Solar optimisation• Extension to 5 year warranty <p data-bbox="1057 1168 1498 1202">Internet connectivity for the unit</p> <ul data-bbox="1057 1210 1274 1245" style="list-style-type: none">• Ethernet only	 <p data-bbox="1923 486 2068 559">Smappee EV Base</p> <ul data-bbox="1625 782 1854 853" style="list-style-type: none">• Charging data• MID metering <p data-bbox="1625 896 2076 968">Infinity & Smart Charging Package need to be purchased separately</p> <ul data-bbox="1625 973 2051 1116" style="list-style-type: none">• Energy data• Overload protection• Solar optimisation• Extension to 5 year warranty <p data-bbox="1625 1168 1911 1202">Internet connectivity</p> <ul data-bbox="1625 1210 2012 1316" style="list-style-type: none">• Ethernet (preferred)• 2.4 GHz Wi-Fi (alternative)• 4G (contact Smappee)

Differences with EV Lines **Business** variants:

- Each charging station **needs separate internet connection**
- Smappee Infinity (energy monitor) needs to be purchased separately for the Overload and Solar optimization capabilities.

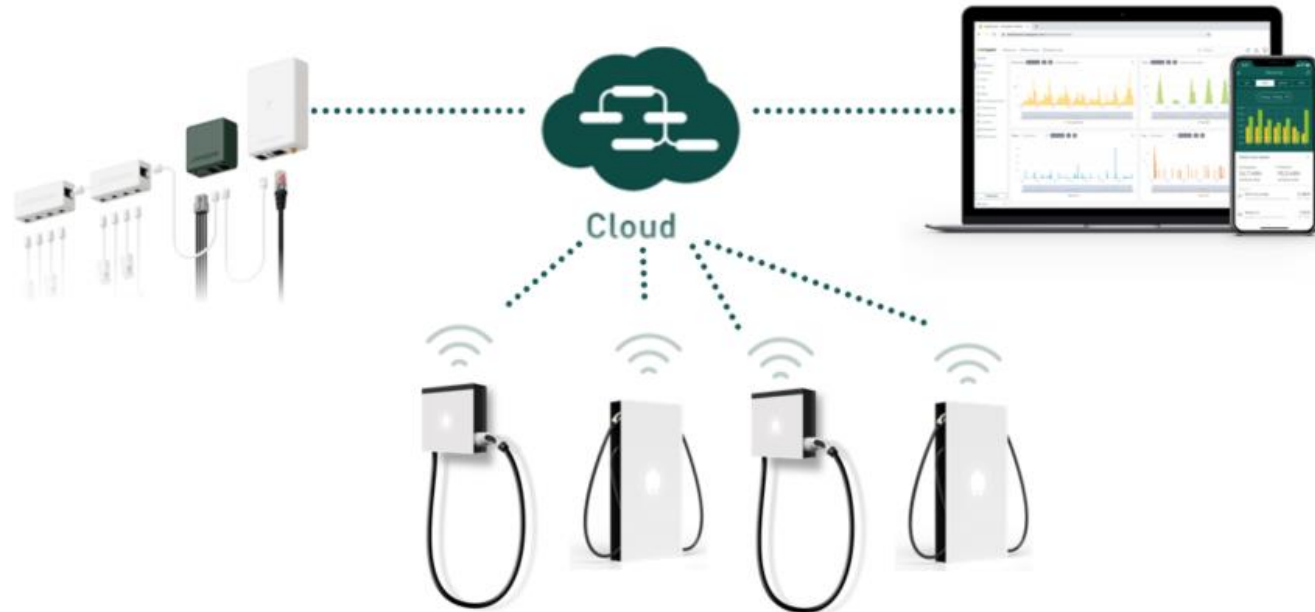

Interesting links & info

Interesting links for partners & installers

- Technical specifications and installation manuals: <https://www.smappee.com/smappee-manuals/>
- Help Center: <https://support.smappee.com/hc/en-gb>
- Blog: <https://www.smappee.com/blog/>
- FAQ: <https://www.smappee.com/faq/>
- **Training Platform:** <https://www.smappee.com/training/>

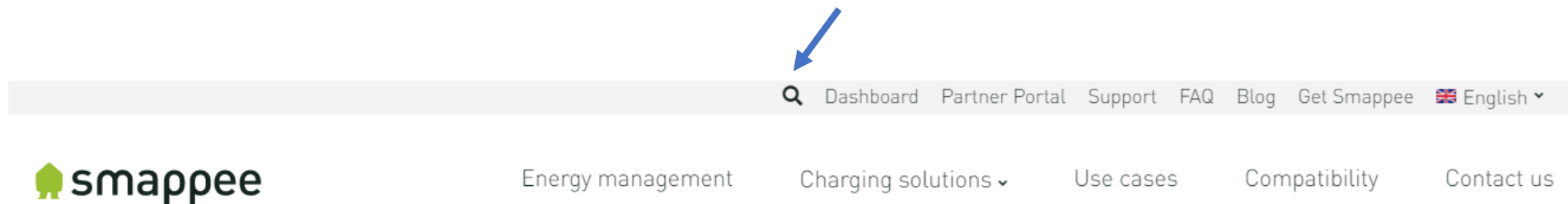

 Use the search function on the Smappee website (www.smappee.com)

Thank you!
-
Questions?